

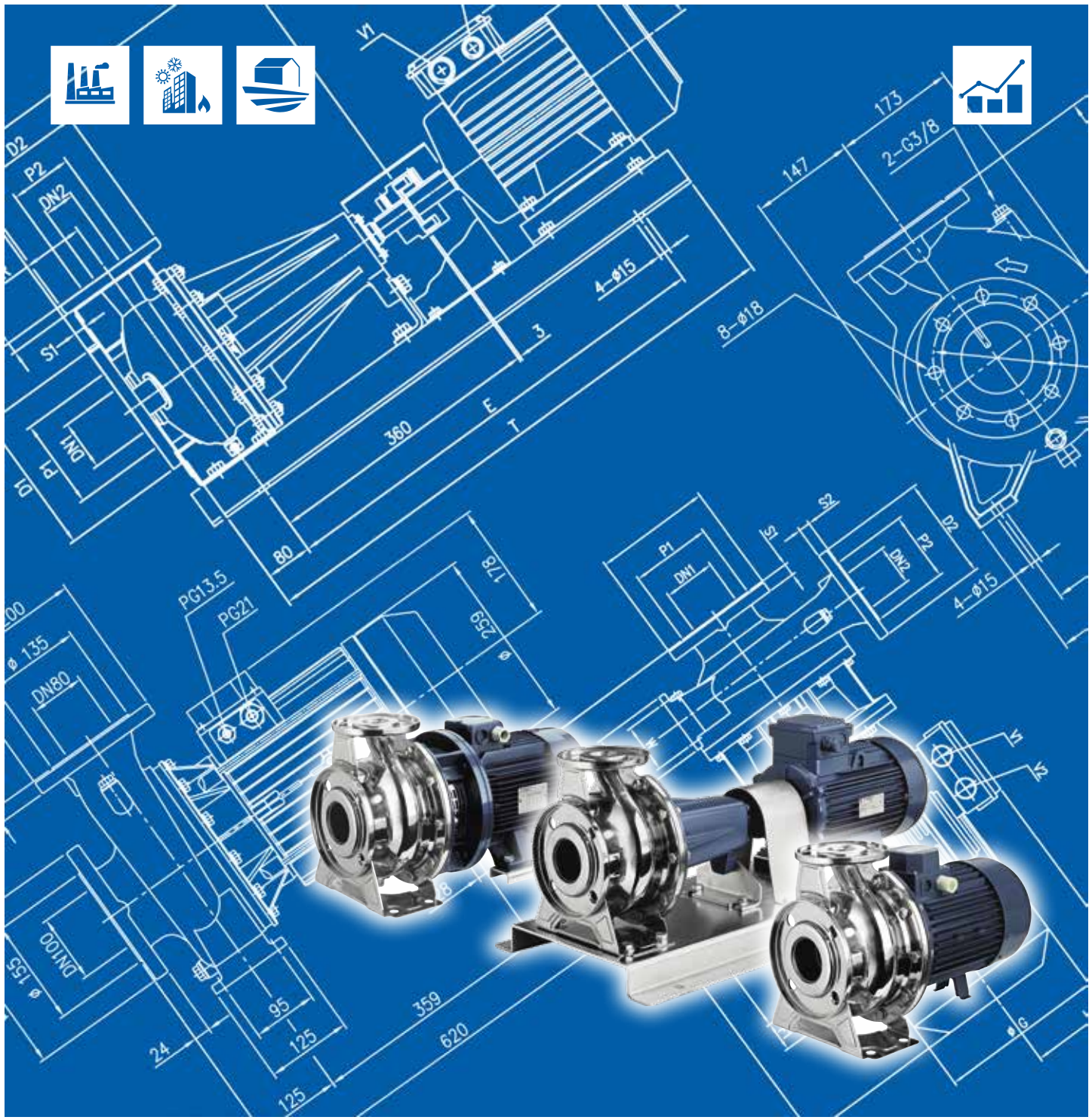

Japanese Technology since 1912

3 SERIES

Data Book 50Hz



	Page
- SPECIFICATION	
SPECIFICATION	200
SPECIFICATION	201
SPECIFICATION	202
PERFORMANCE RANGE	203
SELECTION CHART	204
TYPE KEY	205
PERFORMANCE CURVE SPECIFICATIONS	206
MEI INDEX SPECIFICATIONS	207
PERFORMANCE CURVE 32-125	208
PERFORMANCE CURVE 32-160	209
PERFORMANCE CURVE 32-200	210
PERFORMANCE CURVE 40-125	211
PERFORMANCE CURVE 40-160	212
PERFORMANCE CURVE 40-200	213
PERFORMANCE CURVE 50-125	214
PERFORMANCE CURVE 50-160	215
PERFORMANCE CURVE 50-200	216
PERFORMANCE CURVE 65-125	217
PERFORMANCE CURVE 65-160	218
PERFORMANCE CURVE 65-200	219
PERFORMANCE CURVE 65-250	220
PERFORMANCE CURVE 80-160	221
PERFORMANCE CURVE 80-200	222
PERFORMANCE CURVE 80-250	223
- CONSTRUCTION	
SECTIONAL VIEW DRAWING 3(.)M 32, 40, 50, 65-125/160/200	300
SECTIONAL VIEW TABLE 3(.)M 32, 40, 50, 65-125/160/200	301
SECTIONAL VIEW DRAWING 3LMZ 32, 40, 50, 65-125/160/200	302
SECTIONAL VIEW TABLE 3LMZ 32, 40, 50, 65-125/160/200	303
SECTIONAL VIEW DRAWING 3LM 80-160/11	304
SECTIONAL VIEW DRAWING 3LM 80-160/15R/15/18.5	305
SECTIONAL VIEW TABLE 3LM 80-160	306
SECTIONAL VIEW DRAWING 3(.)S 32, 40, 50	307
SECTIONAL VIEW DRAWING 3(.)S 65-125/160/200	308
SECTIONAL VIEW TABLE 3(.)S 32, 40, 50, 65-125/160/200	309
SECTIONAL VIEW DRAWING 3LSZ 32, 40-125/160, 40-200/5.5/7.5 50-125/160, 50-200/9.2, 65-125, 65-160/7.5/9.2	310
SECTIONAL VIEW DRAWING 3LSZ 40-200/11, 50-200/11/15, 65-160/11/15, 62-200	311
SECTIONAL VIEW TABLE 3LSZ 32, 40, 50, 65-125/160/200	312
SECTIONAL VIEW DRAWING 3LS 80-160	313
SECTIONAL VIEW TABLE 3LS 80-160	314
SECTIONAL VIEW DRAWING 3LS 65-250, 80-200/250	315

CONTENTS

50Hz

Rev. AC

SECTIONAL VIEW TABLE 3LS 65-250, 80-200/250	316
SECTIONAL VIEW DRAWING 3(.)P 32, 40, 50, 65-125/160/200	317
SECTIONAL VIEW TABLE 3(.)P 32, 40, 50, 65-125/160/200	318
SECTIONAL VIEW DRAWING 3LP 80-160	319
SECTIONAL VIEW DRAWING 3LP 65-250, 80-200/250	320
SECTIONAL VIEW DRAWING 3LP 65-250, 80-160/200/250	321
SECTIONAL VIEW TABLE 3LP 80-160	322
SECTIONAL VIEW TABLE 3LP 65-250, 80-200/250	323
BEARINGS 3(.)M	324
BEARINGS 3(.)S-3(.)P	325
MECHANICAL SEAL (standard, H and special version)	326
MECHANICAL SEAL (L version \varnothing 22)	327
MECHANICAL SEAL (L version \varnothing 30-35)	328
MECHANICAL SEAL (HS version and special version \varnothing 22)	329
MECHANICAL SEAL (HS version \varnothing 30)	330
MECHANICAL SEAL (HW, HSW, E and special version)	331
MECHANICAL SEAL (ES version)	332
COUPLING	333
FLEXIBLE COUPLING	334
FITTINGS	335
FITTINGS	336
- DIMENSIONS	
DIMENSIONS 3(.)M 32, 40, 50, 65-125/160	400
DIMENSIONS 3(.)M 50-200, 65-160/15, 65-200	401
DIMENSIONS 3LMZ 32, 40, 50-125/160/200/9.2/11, 65-125/160/7.5/9.2/11	402
DIMENSIONS 3LMZ 50-200/15, 65-160/15, 65-200	403
DIMENSIONS 3LM 80-160/11	404
DIMENSIONS 3LM 80-160/15R/15/18.5	405
DIMENSIONS 3(.)S 32, 40, 50	406
DIMENSIONS 3(.)S 32, 65	407
DIMENSIONS 3(.)S 40, 50, 65	408
DIMENSIONS 3(.)S 32, 40, 50, 65	409
DIMENSIONS 3LSZ 32-125/160, 32-200/3/4, 50-125/2.2, 65-125/4	410
DIMENSIONS 3LSZ 32-200/5.5/7.5, 40-125/160, 40-200/5.5/7.5, 50-125/3/4, 50-160 50-200/9.2, 65-125/5.5/7.5, 65-160/7.5/9.2	411
DIMENSIONS 3LSZ 40-200/11, 50-200/11/15, 65-160/11/15, 65-200	412
DIMENSIONS 3LS 80-160	413
DIMENSIONS 3LS 65-250, 80-200/250	414
DIMENSIONS 3LS 80-200/30/37, 80-250/45	415
DIMENSIONS 3LS 80-250/55	416
DIMENSIONS 3(.)P 32, 40, 50, 65	417
DIMENSIONS TABLE 3(.)P 32, 40, 50, 65	418
DIMENSIONS 3LP 65-250,80	419

CONTENTS

50Hz

Rev. AC

DIMENSIONS 3LP 80-200/30/37, 80-250/45	420
DIMENSIONS 3LP 80-250/55	421
PACKING 3(.)M	422
PACKING 3(.)S	423
PACKING 3(.)P	424
- TECHNICAL DATA	
MOTOR DATA 3(.)M	500
MOTOR DATA 3(.)S-3(.)P	501
NOISE DATA 3(.)M	502
NOISE DATA 3(.)S-3(.)P	503

SPECIFICATION

50Hz

Rev. AC

Version		3M	3S	3P	3LM	3LMZ	3LS	3LSZ	3LP
Pump sizes	32-125	■	■	■	●	◇	●	◇	●
	32-160	■	■	■	●	◇	●	◇	●
	32-200	■	■	■	●	◇	●	◇	●
	40-125	■	■	■	●	◇	●	◇	●
	40-160	■	■	■	●	◇	●	◇	●
	40-200	■	■	■	●	◇	●	◇	●
	50-125	■	■	■	●	◇	●	◇	●
	50-160	■	■	■	●	◇	●	◇	●
	50-200	■	■	■	●	◇	●	◇	●
	65-125	■	■	■	●	◇	●	◇	●
	65-160	■	■	■	●	◇	●	◇	●
	65-200	■	■	■	●	◇	●	◇	●
	65-250	-	-	-	-	-	●	-	●
	80-160	-	-	-	●	-	●	-	●
80-200	-	-	-	-	-	●	-	●	
80-250	-	-	-	-	-	▲	-	▲	

■ Available also with H, HS, HW, HSW, E, Q1Q1EGG, Q1U3EGG, Q1AEGG, U3CEGG, U3U3CEGG version.
U3U3EGG not available for model 65-160/15 and 65-200

● Available also with H, HW, HSW, E, Q1Q1EGG, Q1U3EGG, Q1AEGG, U3CEGG, U3U3EGG version.
U3U3EGG available for model 32, 40, 50, 65-125 and 65-160/7.5/9.2/11

▲ Available also with H, HW, HSW, ES, Q1Q1EGG, Q1U3EGG, Q1AEGG, U3CEGG version.

— Not available.

◇ Available only standard version.

SPECIFICATION

50Hz

Rev. AC

		PUMP							
Version		3M	3S	3P	3LM(Z)	3LS(Z)	3LP		
Liquid Handled	Type of liquid	Clean water and moderately aggressive fluids							
	Temperature [°C]	/			Drinking water and water contains glycol for E and ES version				
Maximum working pressure [MPa]		1							
Construction	Impeller	Closed centrifugal type for 32, 40, 50 version Reinforced laser welding for 40-200/11, 50-200/15 Closed centrifugal three dimensional blades for 65 and 80 version							
	Shaft seal type	Mechanical seal			Mechanical seal with stationary ring secured against rotation				
	Bearing	Sealed ball bearing							
Pipe Connection	Suction	32-125/160/200	Flange DN50 according DIN 2532 Standard						
		40-125/160/200	Flange DN65 according DIN 2532 Standard						
		50-125/160/200	Flange DN80 according DIN 2532 Standard						
		65-125/160/200/250	Flange DN100 according DIN 2532 Standard						
	Discharge	32-125/160/200	Flange DN32 according DIN 2532 Standard						
		40-125/160/200	Flange DN40 according DIN 2532 Standard						
		50-125/160/200	Flange DN50 according DIN 2532 Standard						
		65-125/160/200/250	Flange DN65 according DIN 2532 Standard						
Material	Casing	32-125/160/200	EN 1.4301 (AISI 304)		EN 1.4404 (AISI 316L)				
		40-125/160/200							
		50-125/160/200							
		65-125/160/200							
	Impeller	65-250	/		CF8M - EN 1.4408 (AISI 316)				
		80-160/200/250							
		32-125/160/200	EN 1.4301 (AISI 304)		EN 1.4404 (AISI 316L)				
		40-125/160/200							
	Casing cover	50-125/160/200	EN 1.4301 (AISI 304)		EN 1.4404 (AISI 316L)				
		65-125/160/200							
		65-250	/		CF8M - EN 1.4408 (AISI 316)				
		80-160/200/250							
	Mechanical seal	32-125/160/200	Ceramic/Carbon/NBR		SiC/SiC/FPM (L version)				
		40-125/160/200	(For version see page 327+333)		(For version see page 327+333)				
		50-125/160/200							
		65-125/160/200							
	Shaft	65-250	/		SiC/Carbon/EPDM (ES version) [2]				
		80-160/200			FPM [3]				
		80-250							
		O-ring			NBR [1]				
			Bracket	32, 40, 50, 65-125	d=19	EN 1.4301 (AISI 304)		EN 1.4404 (AISI 316L)	
				65-160/11	d=22				
				50-200/15	d=24				
65-160/15				d=24			EN 1.4462 (Duplex stainless steel)		
65-200		d=24				EN 1.4404 (AISI 316L)			
80-160		d=24		/		EN 1.4462 (Duplex stainless steel)			
Shaft		80-200/22	d=24						
	80-200/30-37	d=29							
	80-250	d=29							
Applicable standard of test		Cast iron - Aluminium ISO 9906:2012 – Grade 3B							

[1] FPM for H-HS-HW-HSW version / EPDM for Q1AEGG, U3U3EGG, Q1Q1EGG, Q1U3EGG, U3EGG

[2] ES option only for 80-250 2 poles Ø35

[3] EPDM for E-ES version and for Q1AEGG, U3U3EGG, Q1Q1EGG, Q1U3EGG, U3CEGG

SPECIFICATION

50Hz

Rev. AC

MOTOR				
Type	3(.)M(Z)		3(.)S(Z)	3(.)P
	Electric - TEFC			
	Single Phase	Three Phase		
Efficiency level (Reg. 640/2009)	/		IE3	
No. of Poles	2			
Rotation speed [min ⁻¹]	≈ 2900			
Insulation Class	F		F (temperature rise class B)	
Protection degree (CEI EN 60034-5)	IP 55			
Power rating	[kW]	1.1 ÷ 2.2	1.1 ÷ 22	1.1 ÷ 55
	[HP]	1.5 ÷ 3.0	1.5 ÷ 30	1.5 ÷ 7.5
Frequency [Hz]	50			
Voltage [V]	230 ±10%	230/400 ±10% (up to 4.0 kW) 400/690 ±10% (5.5 kW and above)		
Over load protection	Provided by the user			
Casing material	Aluminium			
Motor support	Cast iron - Alluminium			
Dimensions of cable entry	M20x1.5	PG13.5	M32x1.5	
		PG16	M40x1.5	
		PG21	M50x1.5	
		M20x1.5, M25x1.5		
Flange mount (IEC motor)	/	3(.)S IMB5 (up to 2.2 kW) IMB35 (3 kW and above) 3LSZ IM B35		IM B3

SELECTION CHART

50Hz

Rev. AC

PERFORMANCE RANGE

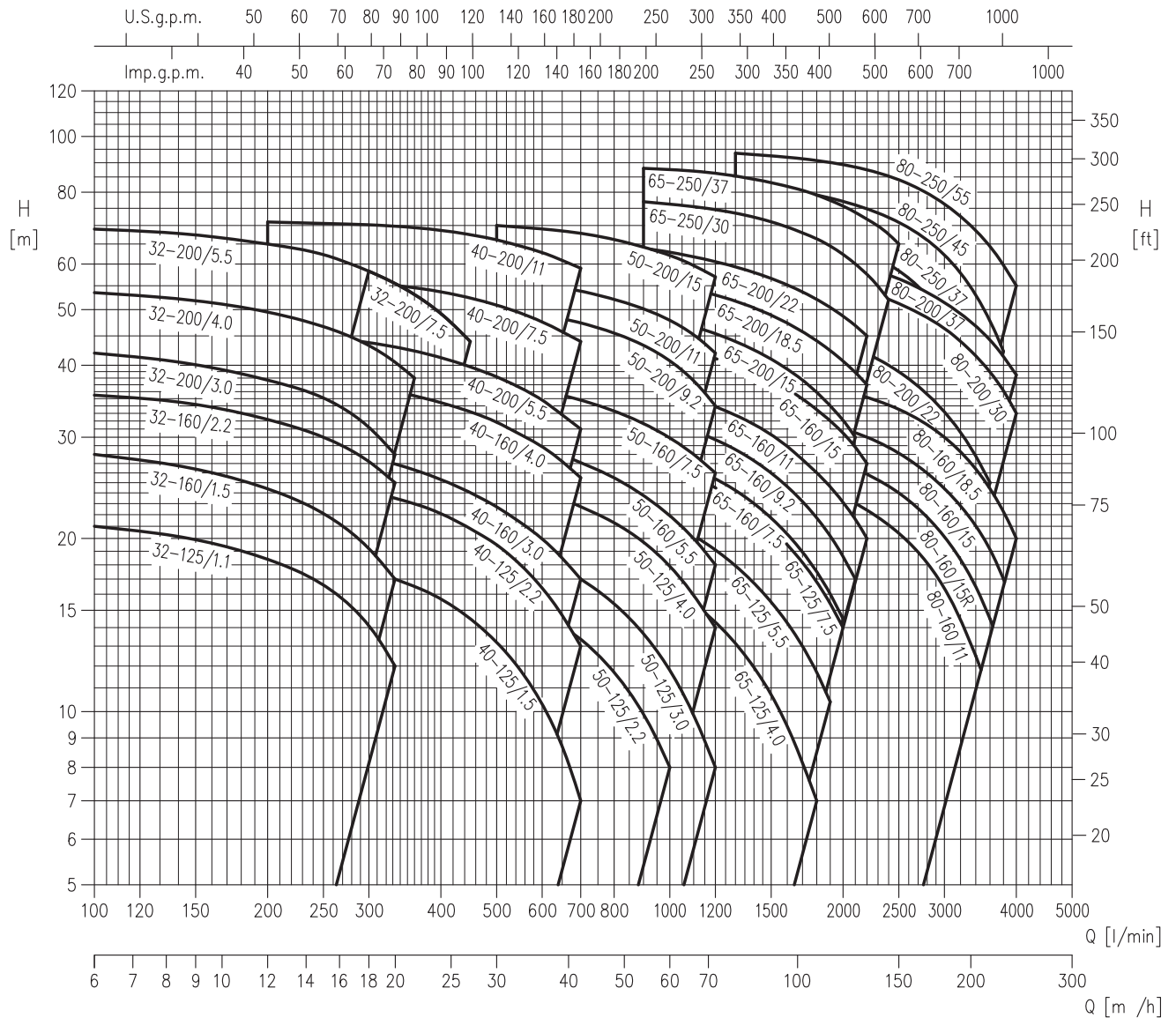

SELECTION CHART

50Hz

Rev. AC

SELECTION CHART

3 SERIES: 32, 40, 50 Version

Pump type	Power		Flow rate (m³/h)															
	[kW]	[HP]	0	6	9	12	18	20	22	24	27	30	36	42	48	60	72	
32-125/1.1(M) *	1.1	1.5	22.5	21	19.9	18.4	14.1	12	-	-	-	-	-	-	-	-	-	
32-160/1.5(M) *	1.5	2	29.5	28	26.5	24.5	19.2	17	-	-	-	-	-	-	-	-	-	
32-160/2.2(M) *	2.2	3	37	35.5	34	32	27	25	-	-	-	-	-	-	-	-	-	
32-200/3.0	3	4	44	42	40	37.5	31	28	-	-	-	-	-	-	-	-	-	
32-200/4.0	4	5.5	55	53.5	52	49.5	43.5	40.5	38	-	-	-	-	-	-	-	-	
32-200/5.5	5.5	7.5	70.5	69	67.5	65	58.5	-	-	-	-	-	-	-	-	-	-	
32-200/7.5	7.5	10	70.5	69	67.5	65	58.5	55.5	53	49	44	-	-	-	-	-	-	
40-125/1.5(M) *	1.5	2	20	-	-	19	17.6	17	16.5	15.7	14.5	13.2	10.3	7	-	-	-	
40-125/2.2(M) *	2.2	3	26.5	-	-	25.5	24	23.5	23	22	21	19.5	16.4	13	-	-	-	
40-160/3.0	3	4	31	-	-	29.5	27.5	27	26.5	25.5	24	22.5	20	17	-	-	-	
40-160/4.0	4	5.5	40	-	-	38.5	37	36	35.5	34.5	33	32	29	25.5	-	-	-	
40-200/5.5	5.5	7.5	47	-	-	45.5	44	43	42.5	41	39.5	38	35	31	-	-	-	
40-200/7.5	7.5	10	58	-	-	57	55.5	55	54.5	53.5	52.5	51	47.5	44	-	-	-	
40-200/11	11	15	72	-	-	71	70	70	69.5	68.5	67.5	66	63	59	-	-	-	
50-125/2.2(M) *	2.2	3	19	-	-	-	-	-	-	17.5	17	16.3	14.9	13.4	11.7	8	-	
50-125/3.0	3	4	22.7	-	-	-	-	-	-	21.7	21.4	21	19.9	18.5	16.9	13.3	9.5	
50-125/4.0	4	5.5	26.5	-	-	-	-	-	-	26	25.5	25	24	22.5	21.5	17.9	14	
50-160/5.5	5.5	7.5	33	-	-	-	-	-	-	31	30.5	30	28.5	27	25.5	22	18	
50-160/7.5	7.5	10	40	-	-	-	-	-	-	38.5	38	37.5	36	35	33.5	30	26	
50-200/9.2	9.2	12.5	53	-	-	-	-	-	-	-	50	49	47.5	45.5	40.5	34		
50-200/11	11	15	59	-	-	-	-	-	-	-	56	55	54	52	48	42		
50-200/15	15	20	72	-	-	-	-	-	-	-	70	69	68	66	62	57		

* Single phase version only for 3M type

3 SERIES: 65, 80 Version

Pump type	Power		Flow rate (m³/h)																	
	[kW]	[HP]	0	36	42	54	78	90	102	114	126	132	138	144	150	180	204	216	228	240
65-125/4.0	4	5.5	22.2	19.8	19	17.3	13.3	11	8.6	6.3	-	-	-	-	-	-	-	-	-	-
65-125/5.5	5.5	7.5	27	-	24	22.2	18	15.7	13.3	10.8	8	-	-	-	-	-	-	-	-	-
65-125/7.5	7.5	10	32	-	29.5	27.8	23.5	21.1	18.7	16.1	13.4	12	-	-	-	-	-	-	-	-
65-160/7.5	7.5	10	32	-	30	28.6	24.8	22.5	19.9	17.1	14.2	-	-	-	-	-	-	-	-	-
65-160/9.2	9.2	12.5	36.5	-	34.5	32.8	28.8	26.5	23.9	21.1	18.3	16.8	-	-	-	-	-	-	-	-
65-160/11	11	15	40.5	-	38.5	37.1	33.1	30.9	28.4	25.8	23	21.5	20	-	-	-	-	-	-	-
65-160/15	15	20	48	-	45.5	44	40	37.8	35.3	32.6	29.6	28	26.5	-	-	-	-	-	-	-
65-200/15	15	20	53.5	-	51	49	44	41.5	38.4	35.3	31.8	30	-	-	-	-	-	-	-	-
65-200/18.5	18.5	25	60.5	-	58.5	56.5	51.5	49	46	43	39.7	38	36.3	-	-	-	-	-	-	-
65-200/22	22	30	67	-	65.5	64	59.5	57	54	51	48	46.5	45	-	-	-	-	-	-	-
65-250/30	30	40	78	-	-	77	73.5	71	68	64.5	60	57.5	55	52	-	-	-	-	-	-
65-250/37	37	50	89	-	-	88	85.5	83	80.5	77.5	74	72	70	67.5	65	-	-	-	-	-
80-160/11	11	15	29	-	-	-	27.3	26.4	25.4	24.2	23	22.4	21.8	21.1	20.4	16.4	12.5	-	-	-
80-160/15R	15	20	32	-	-	-	30.5	29.7	28.8	27.7	26.5	25.9	25.3	24.6	24	20.1	16.5	14.5	-	-
80-160/15			35	-	-	-	34	33.3	32.5	31.5	30.5	30	29.4	28.8	28.1	24.4	21	19.1	17	-
80-160/18.5	18.5	25	40	-	-	-	39	38.4	37.6	36.7	35.7	35.2	34.7	34.1	33.5	30	26.4	24.4	22.3	20
80-200/22	22	30	50	-	-	-	48	47	45.5	44.5	43	42	41	40	39	33.2	27.8	25	-	-
80-200/30	30	40	60	-	-	-	58.5	58	57	56	54.5	54	53	52	51	46.5	41.5	39	36.1	33
80-200/37	37	50	66	-	-	-	64	63	62	61	59.5	59	58	57.5	56.5	51.5	47	44.5	41.5	38.5
80-250/37	37	50	73	-	-	-	71.5	70.5	68.5	66.5	64	63	61.5	60	58.5	48.5	38	-	-	-
80-250/45	45	60	84	-	-	-	82.5	81.5	80	78	76	75	73.5	72.5	71	62	53	48	42.5	-
80-250/55	55	75	95	-	-	-	93.5	92.5	91.5	90	88.5	87.5	86.5	85.5	84	76.5	68.5	64.5	60	55

TYPE KEY AND CURVE SPECIFICATIONS

50Hz

Rev. AC

TYPE KEY

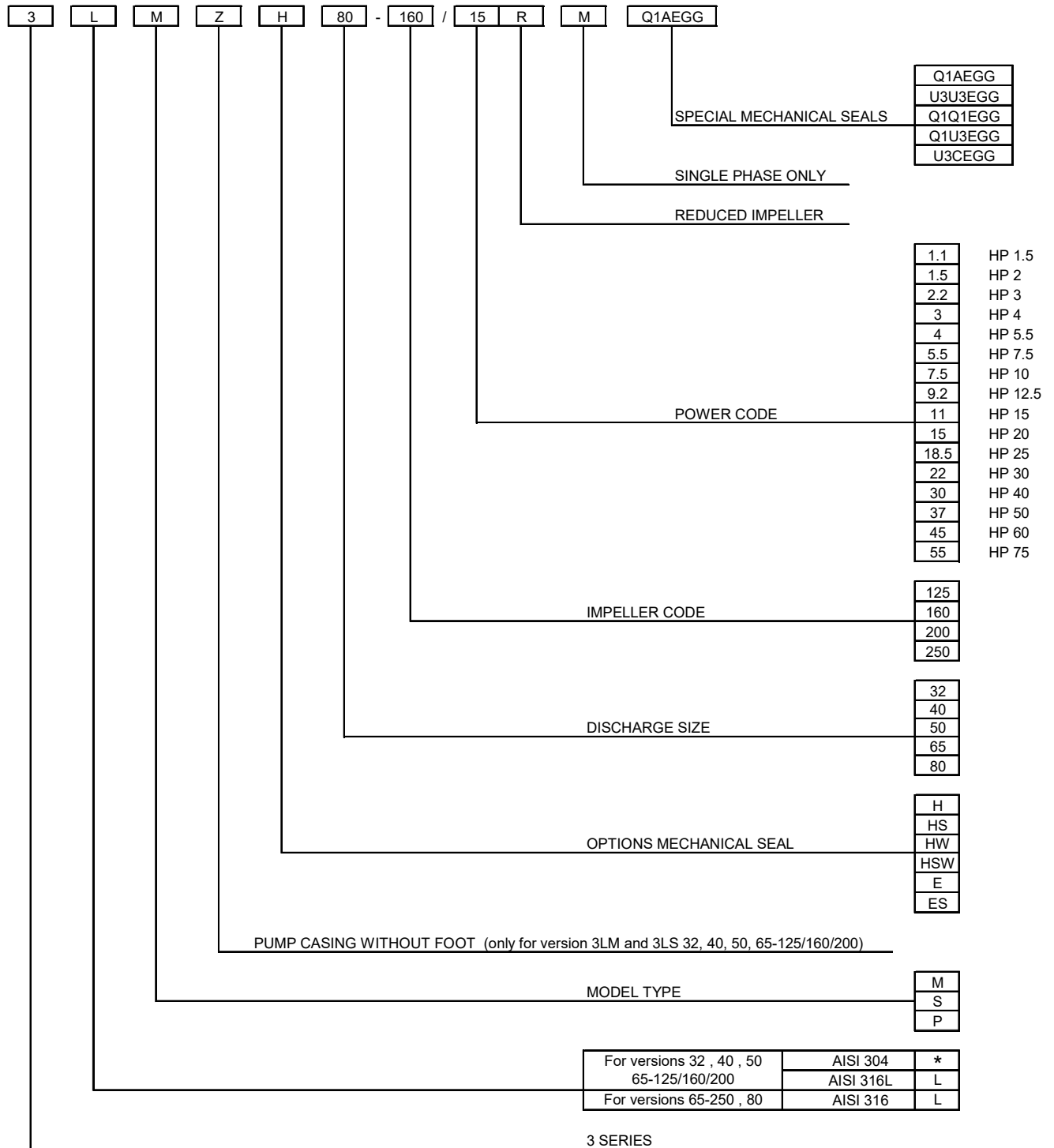

*) No indication

PERFORMANCE CURVE SPECIFICATIONS

The specifications below qualify the curves shown on the following pages.

Tolerances according to ISO 9906:2012 - Grade 3B

The curves refer to effective speed of asynchronous motors at 50 Hz, 2 poles.

Measurements were carried out with clean water at 20°C of temperature and with a kinematic viscosity of $\nu = 1 \text{ mm}^2/\text{s}$ (1 cSt)

The NPSH curve is an average curve obtained in the same conditions of performance curves.

The continuous curves indicate the recommended working range. The dotted curve is only a guide.

In order to avoid the risk of over-heating, the pumps should not be used at a flow rate below 10% of best efficiency point.

Symbols explanation:

- Q = volume flow rate
- H = total head
- P_2 = pump power input (shaft power)
- η = pump efficiency
- NPSH = net positive suction head required by the pump
- MEI = minimum efficiency index

MEI INDEX SPECIFICATION

The minimum efficiency index (MEI) is a measure of the quality of a pump size in respect to its mean efficiency. The minimum efficiency index is based on the hydraulic efficiency and on the head at the best efficiency point.

The efficiency of a pump with trimmed impeller is usually lower than that of a pump with the full impeller diameter. The trimming of the impeller will adapt the pump to a fixed duty point, leading to a reduced energy consumption. The minimum efficiency index (MEI) is based on the full impeller diameter.

The operation of these water pumps with variable duty points may be more efficient and economical when controlled, for example, by the use of a variable speed drive that matches the pump duty to the system.

MEI = 0.4 for ESCC 2900 rpm

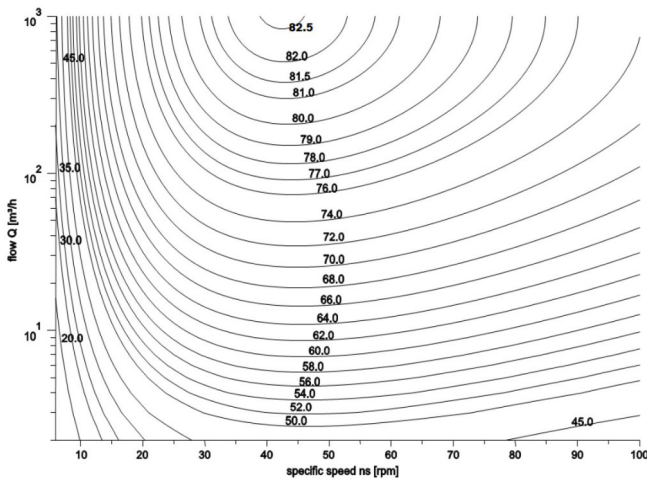

MEI = 0.7 for ESCC 2900rpm

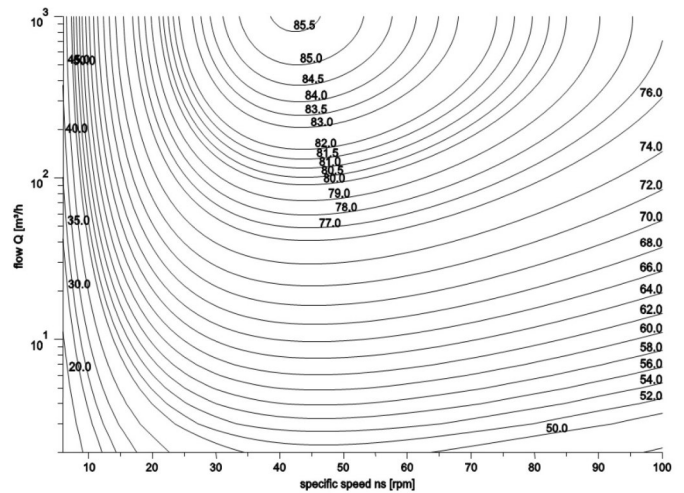

MEI = 0.4 for ESOB 2900 rpm

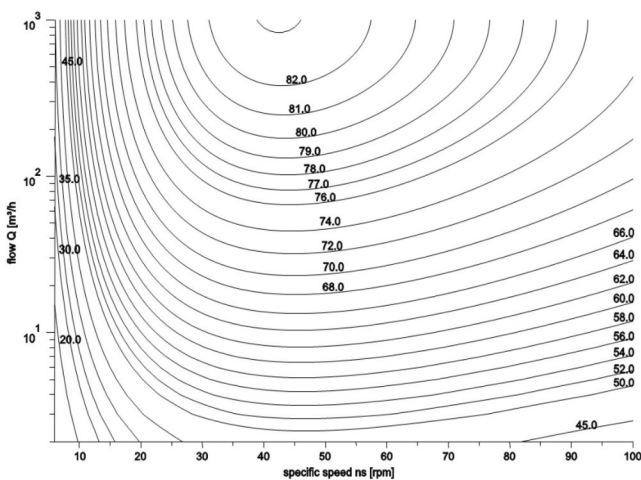

MEI = 0.7 for ESOB 2900rpm

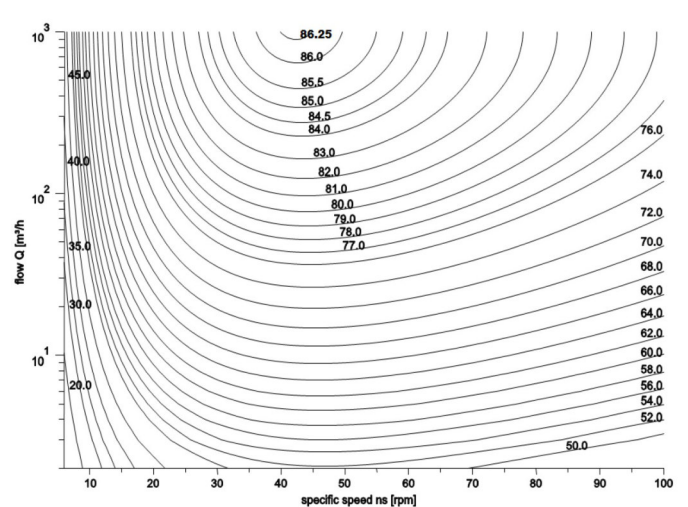

32-125/1.1 (1.1kW) MEI > 0.40 – impeller diameter = 133 mm

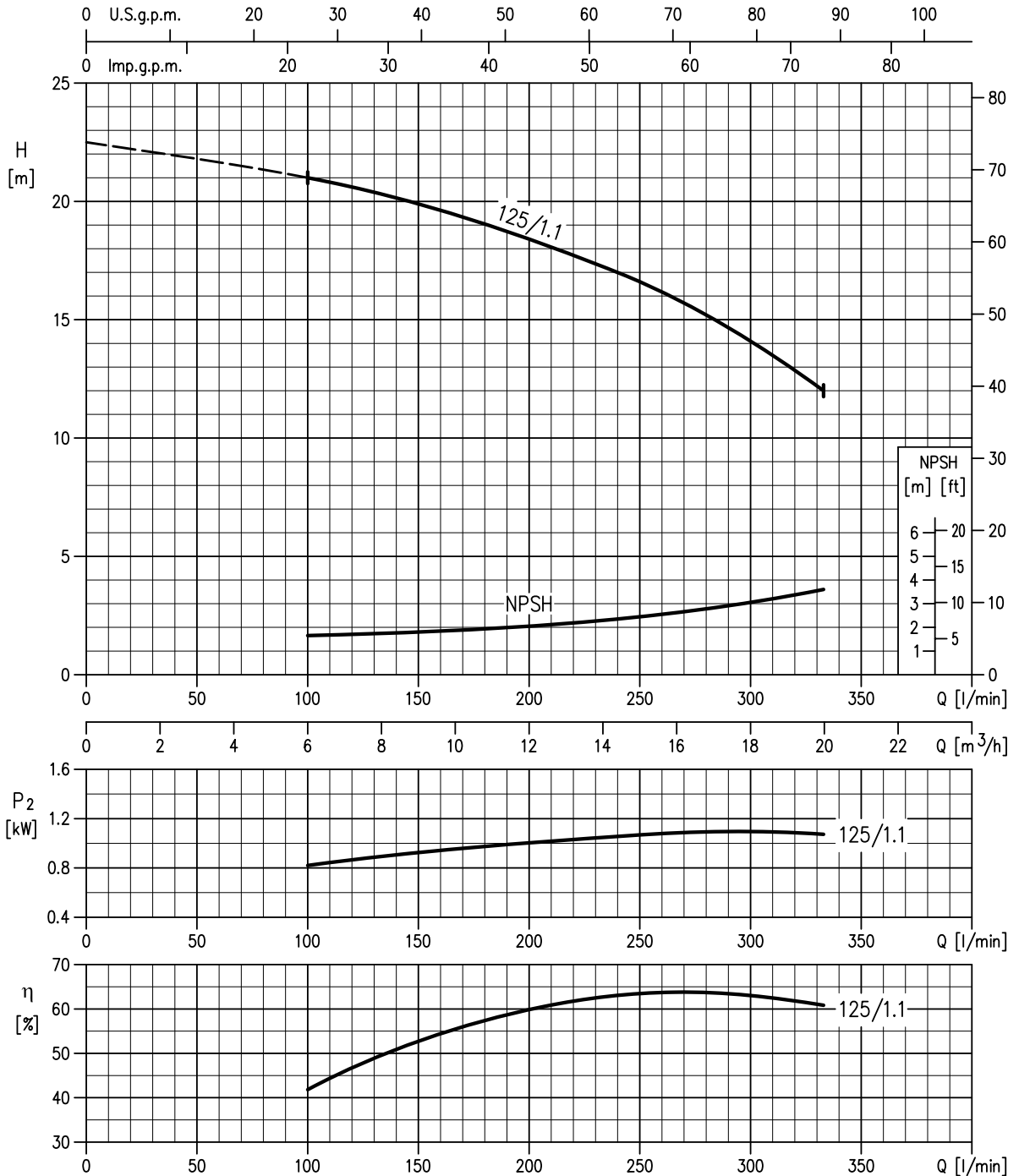

Rotation speed ≈ 2900 min⁻¹
 Test standard: ISO 9906:2012 - Grade 3B

32-160/1.5 (1.5kW) MEI > 0.70 – impeller diameter = 151 mm
 32-160/2.2 (2.2kW) MEI > 0.70 – impeller diameter = 166 mm

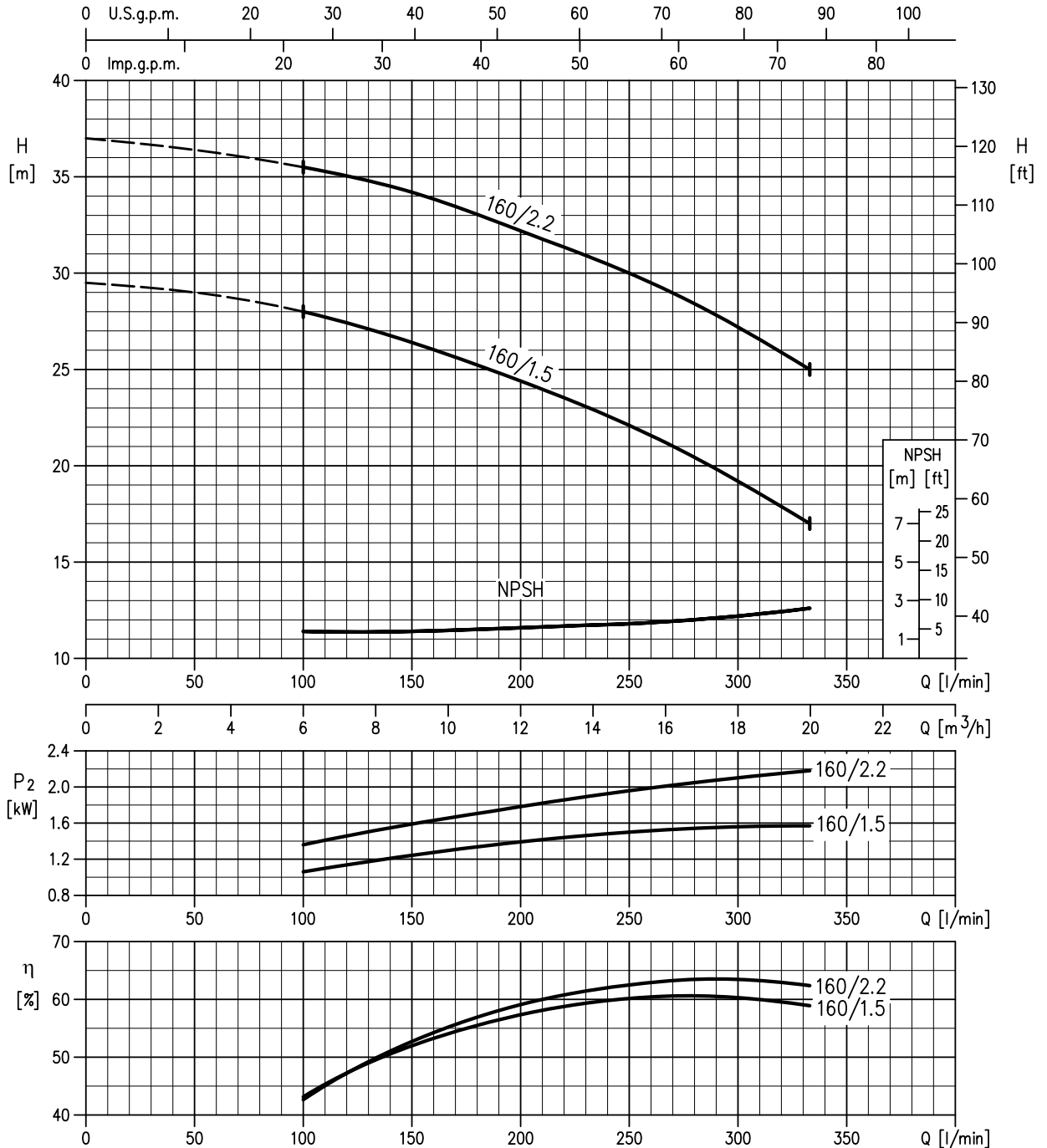

Rotation speed ≈ 2900 min⁻¹
 Test standard: ISO 9906:2012 - Grade 3B

PERFORMANCE CURVE

50Hz

Rev. AC

32-200/3 (3.0kW) MEI > 0.70 – impeller diameter = 186 mm
 32-200/4 (4.0kW) MEI > 0.70 – impeller diameter = 200 mm
 32-200/5.5 (5.5kW) MEI > 0.70 – impeller diameter = 224 mm
 32-200/7.5 (7.5kW) MEI > 0.70 – impeller diameter = 224 mm

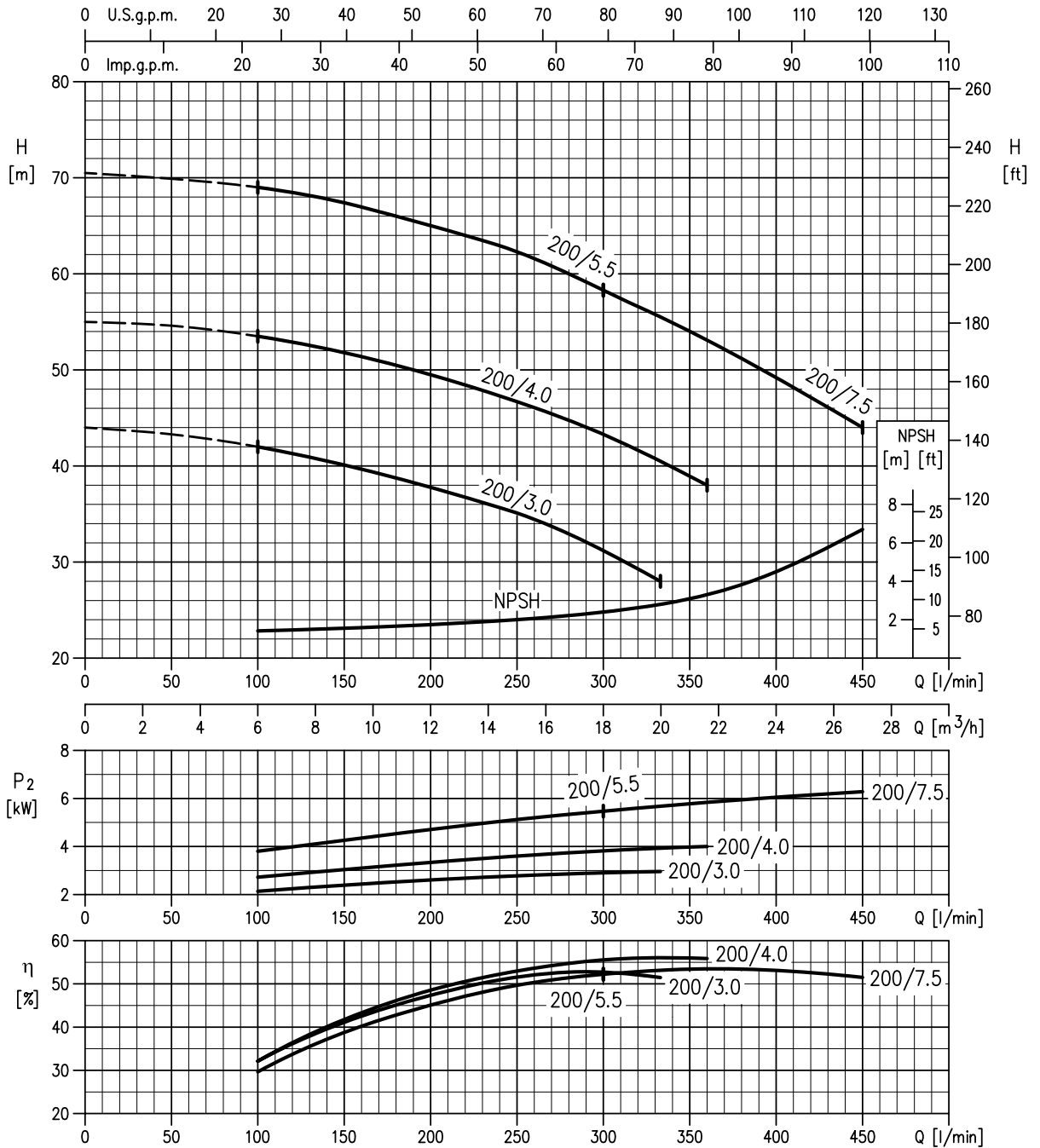

Rotation speed ≈ 2900 min⁻¹
 Test standard: ISO 9906:2012 - Grade 3B

40-125/1.5 (1.5kW) MEI > 0.70 – impeller diameter = 125 mm
 40-125/2.2 (2.2kW) MEI > 0.70 – impeller diameter = 140 mm

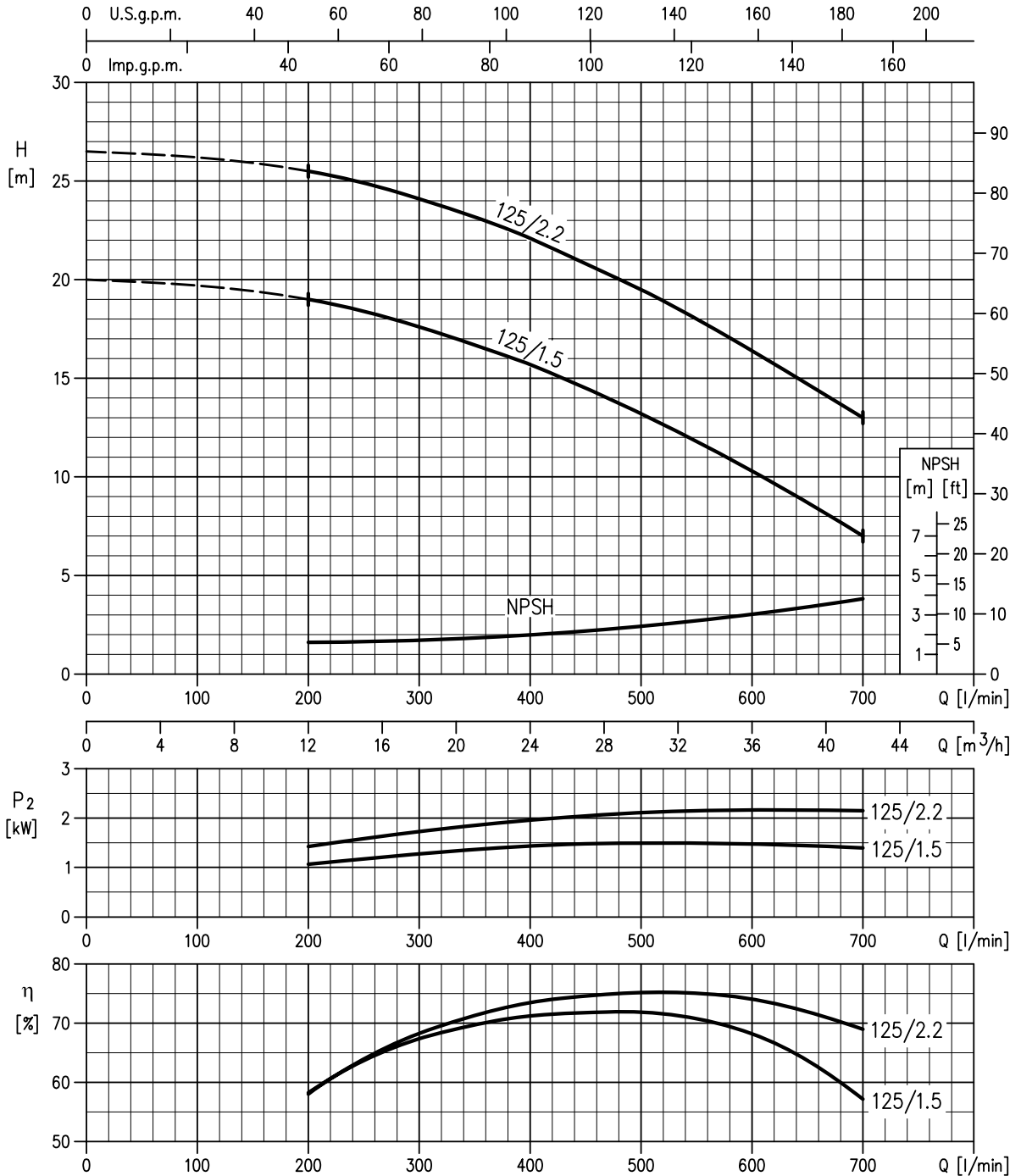

Rotation speed ≈ 2900 min⁻¹
 Test standard: ISO 9906:2012 - Grade 3B

40-160/3 (3.0kW) MEI > 0.70 – impeller diameter = 151 mm
 40-160/4 (4.0kW) MEI > 0.70 – impeller diameter = 166 mm

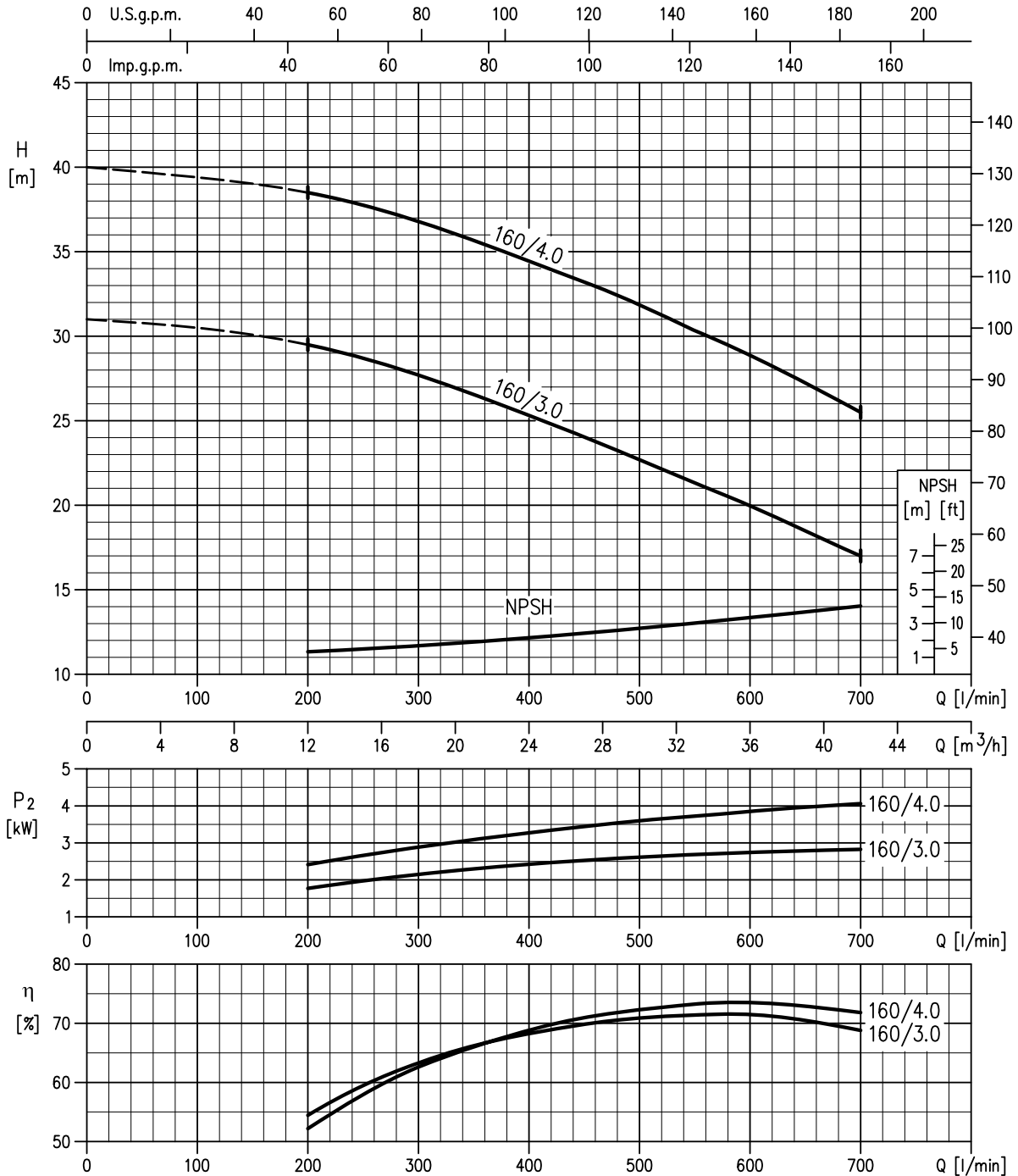

Rotation speed $\approx 2900 \text{ min}^{-1}$
 Test standard: ISO 9906:2012 - Grade 3B

40-200/5.5 (5.5kW) MEI > 0.70 – impeller diameter = 183 mm
 40-200/7.5 (7.5kW) MEI > 0.70 – impeller diameter = 200 mm
 40-200/11 (11kW) MEI > 0.70 – impeller diameter = 224 mm

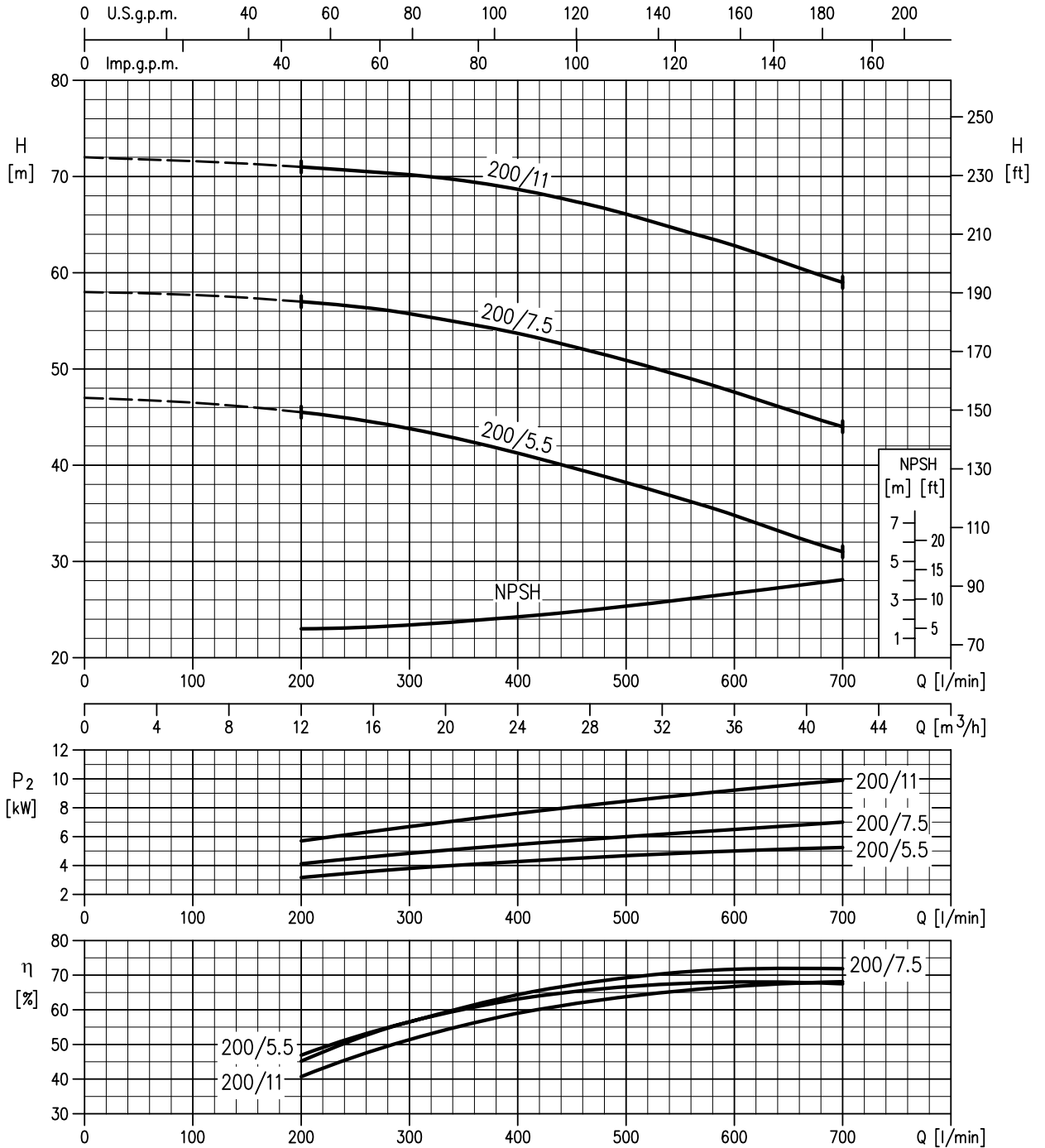

Rotation speed ≈ 2900 min⁻¹
 Test standard: ISO 9906:2012 - Grade 3B

PERFORMANCE CURVE

50Hz

Rev. AC

50-125/2.2 (2.2kW) MEI > 0.50 – impeller diameter = 126 mm

50-125/3 (3.0kW) MEI > 0.50 – impeller diameter = 131 mm

50-125/4 (4.0kW) MEI > 0.50 – impeller diameter = 140 mm

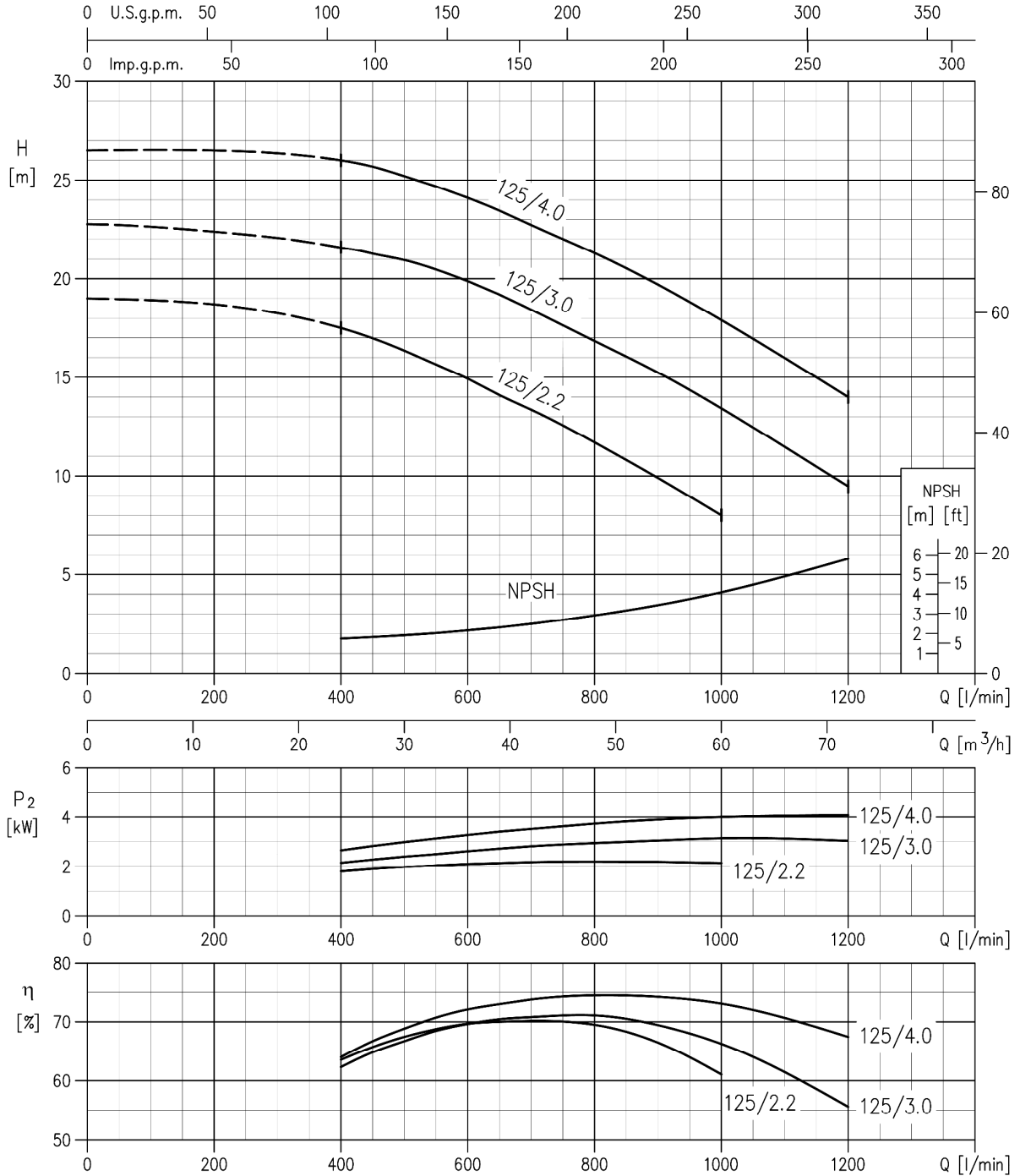

Rotation speed ≈ 2900 min⁻¹
 Test standard: ISO 9906:2012 - Grade 3B

50-160/5.5 (5.5kW) MEI > 0.40 – impeller diameter = 154 mm
 50-160/7.5 (7.5kW) MEI > 0.40 – impeller diameter = 166 mm

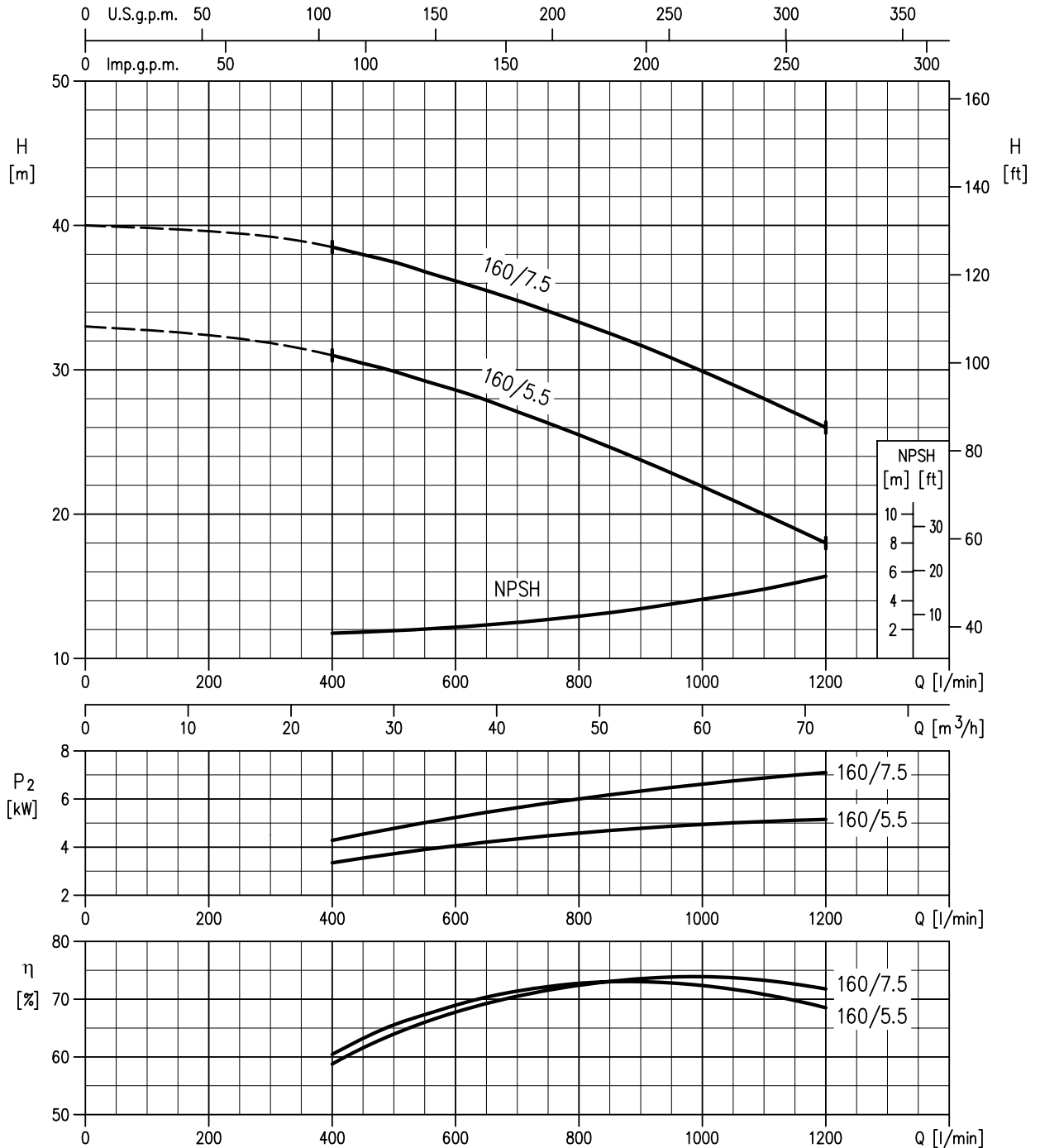

Rotation speed ≈ 2900 min⁻¹
 Test standard: ISO 9906:2012 - Grade 3B

PERFORMANCE CURVE

50Hz

Rev. AC

50-200/9.2 (9.2kW) MEI > 0.70 – impeller diameter = 191 mm
 50-200/11 (11kW) MEI > 0.70 – impeller diameter = 200 mm
 50-200/15 (15kW) MEI > 0.40 – impeller diameter = 224 mm

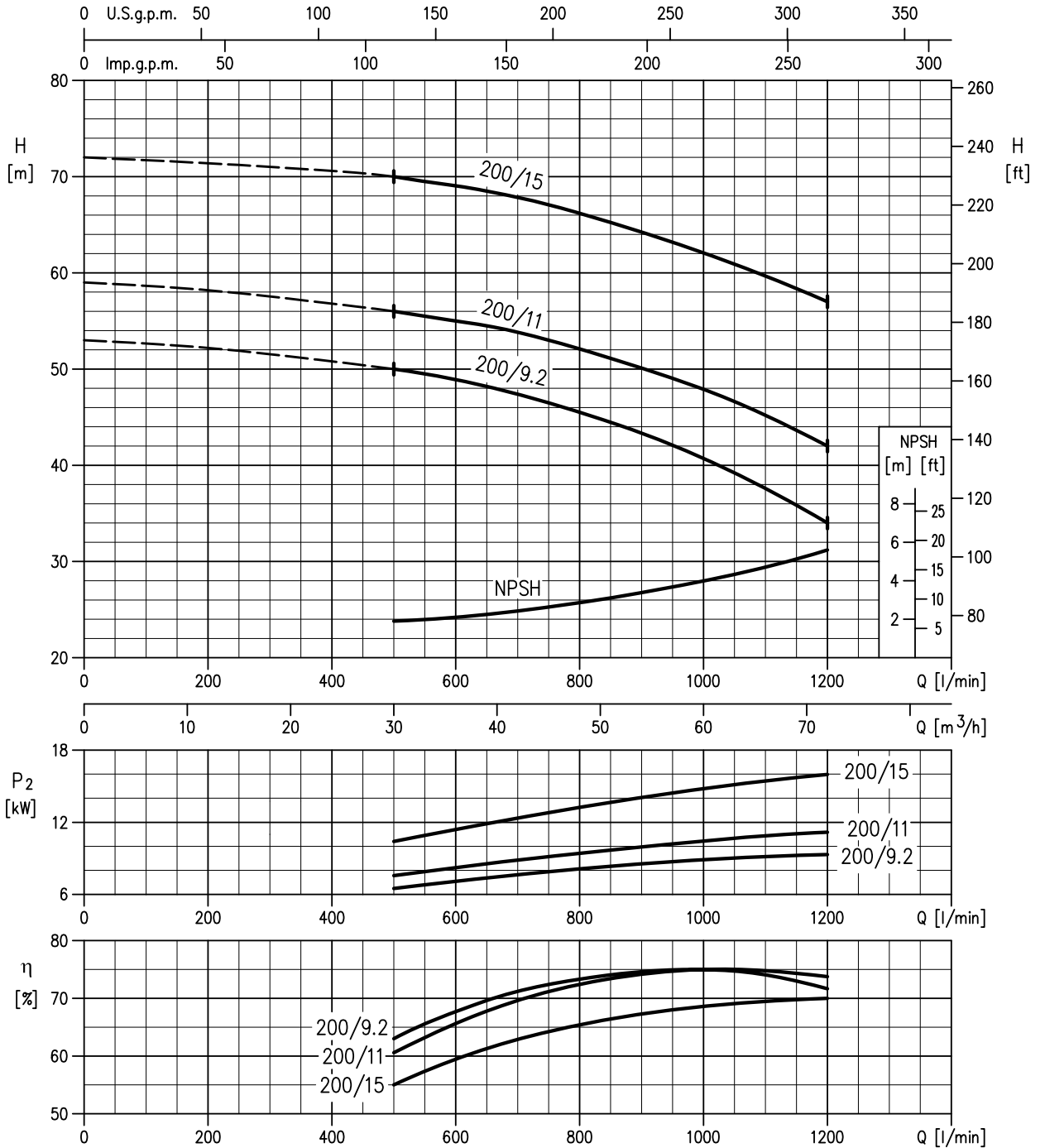

Rotation speed ≈ 2900 min⁻¹
 Test standard: ISO 9906:2012 - Grade 3B

65-125/4 (4.0kW) MEI > 0.50 – impeller diameter = 128 mm
 65-125/5.5 (5.5kW) MEI > 0.50 – impeller diameter = 138 mm
 65-125/7.5 (7.5kW) MEI > 0.50 – impeller diameter = 149 mm

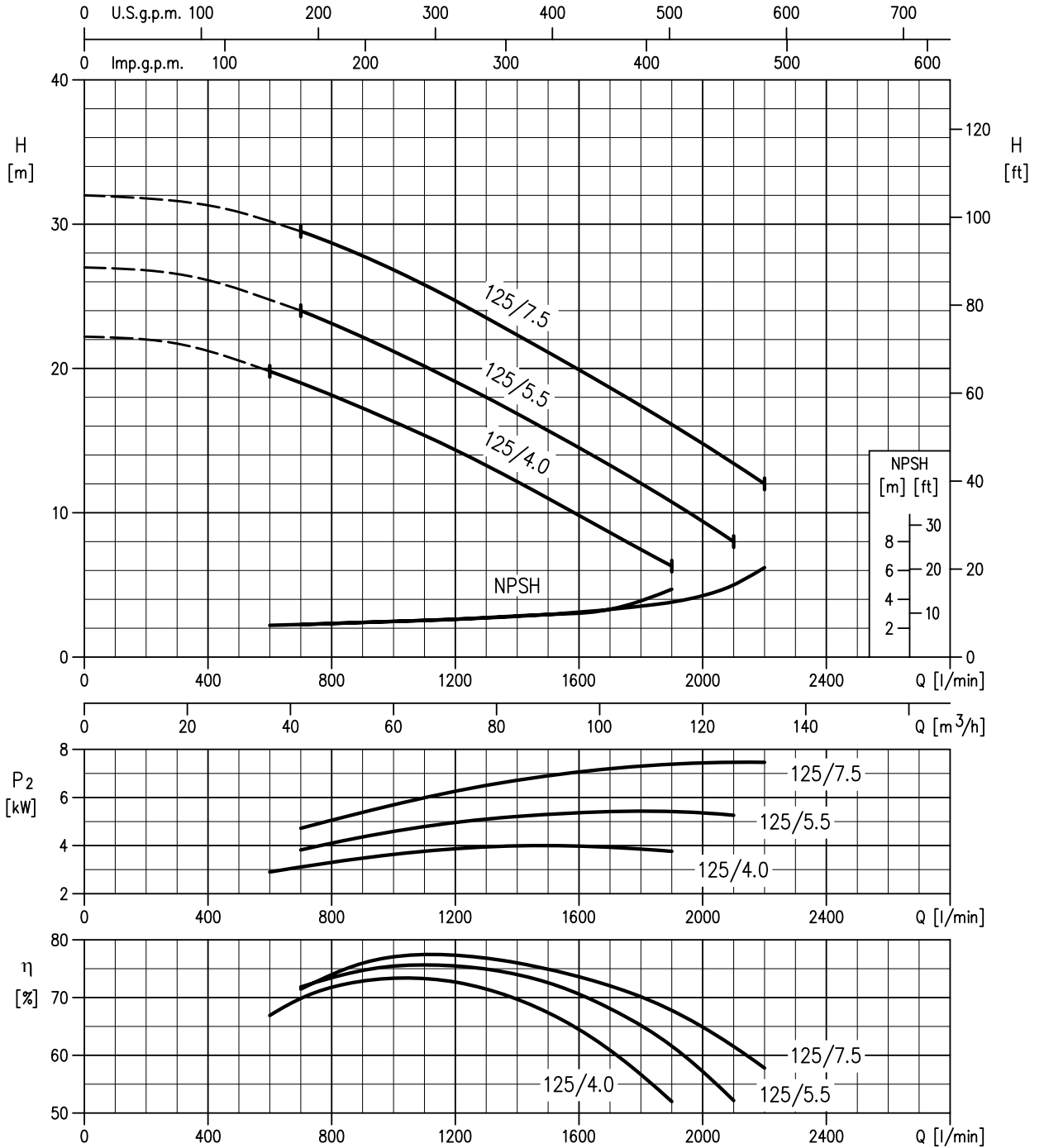

Rotation speed ≈ 2900 min⁻¹
 Test standard: ISO 9906:2012 - Grade 3B

PERFORMANCE CURVE

50Hz

Rev. AC

65-160/7.5 (7.5kW) MEI > 0.70 – impeller diameter = 153 mm
 65-160/9.2 (9.2kW) MEI > 0.70 – impeller diameter = 161 mm
 65-160/11 (11kW) MEI > 0.70 – impeller diameter = 168 mm
 65-160/15 (15kW) MEI > 0.70 – impeller diameter = 178 mm

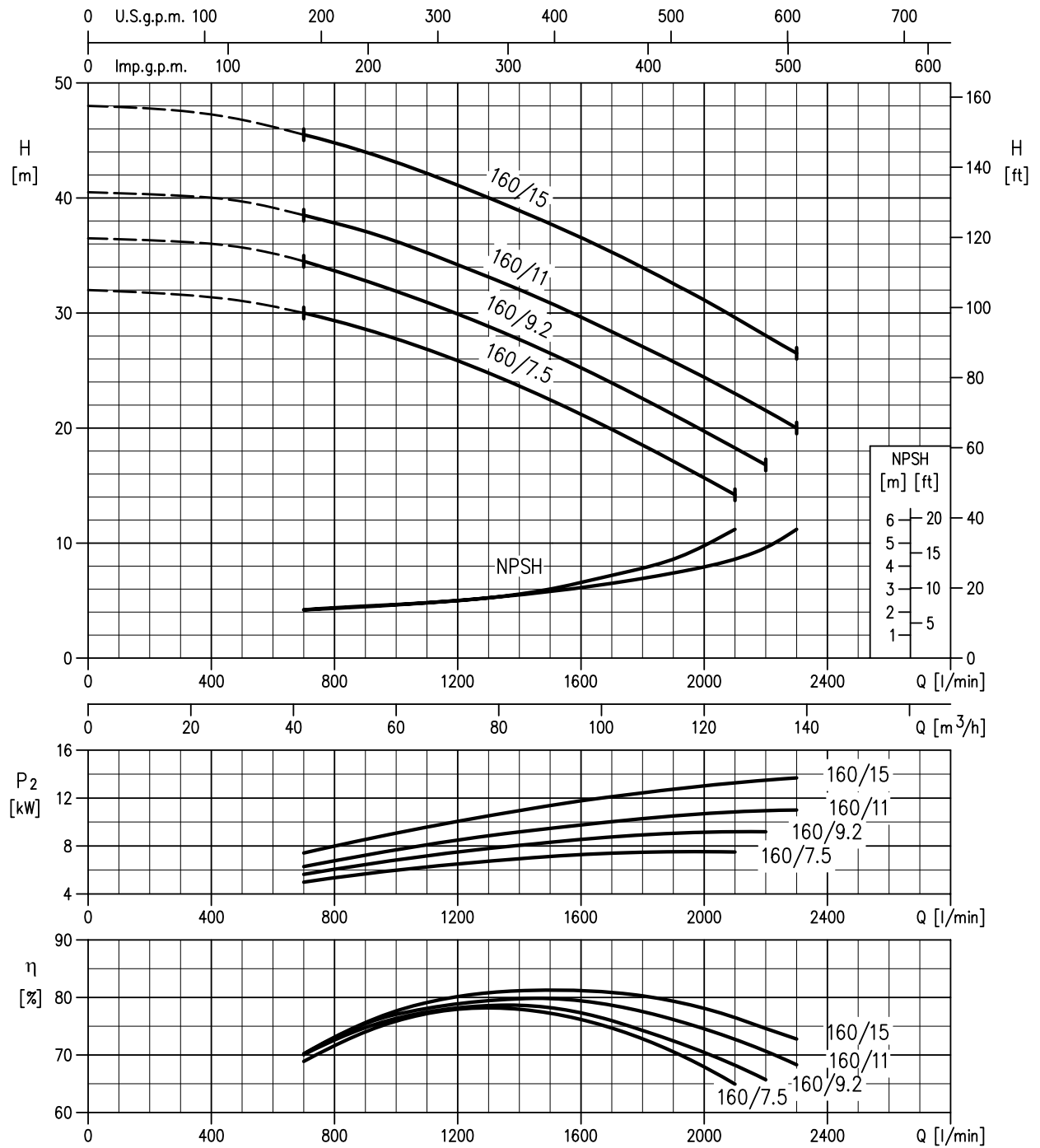

Test standard: ISO 9906:2012 - Grade 3B

65-200/15 (15kW) MEI > 0.70 – impeller diameter = 190 mm
 65-200/18.5 (18.5kW) MEI > 0.70 – impeller diameter = 201 mm
 65-200/22 (22kW) MEI > 0.70 – impeller diameter = 212 mm

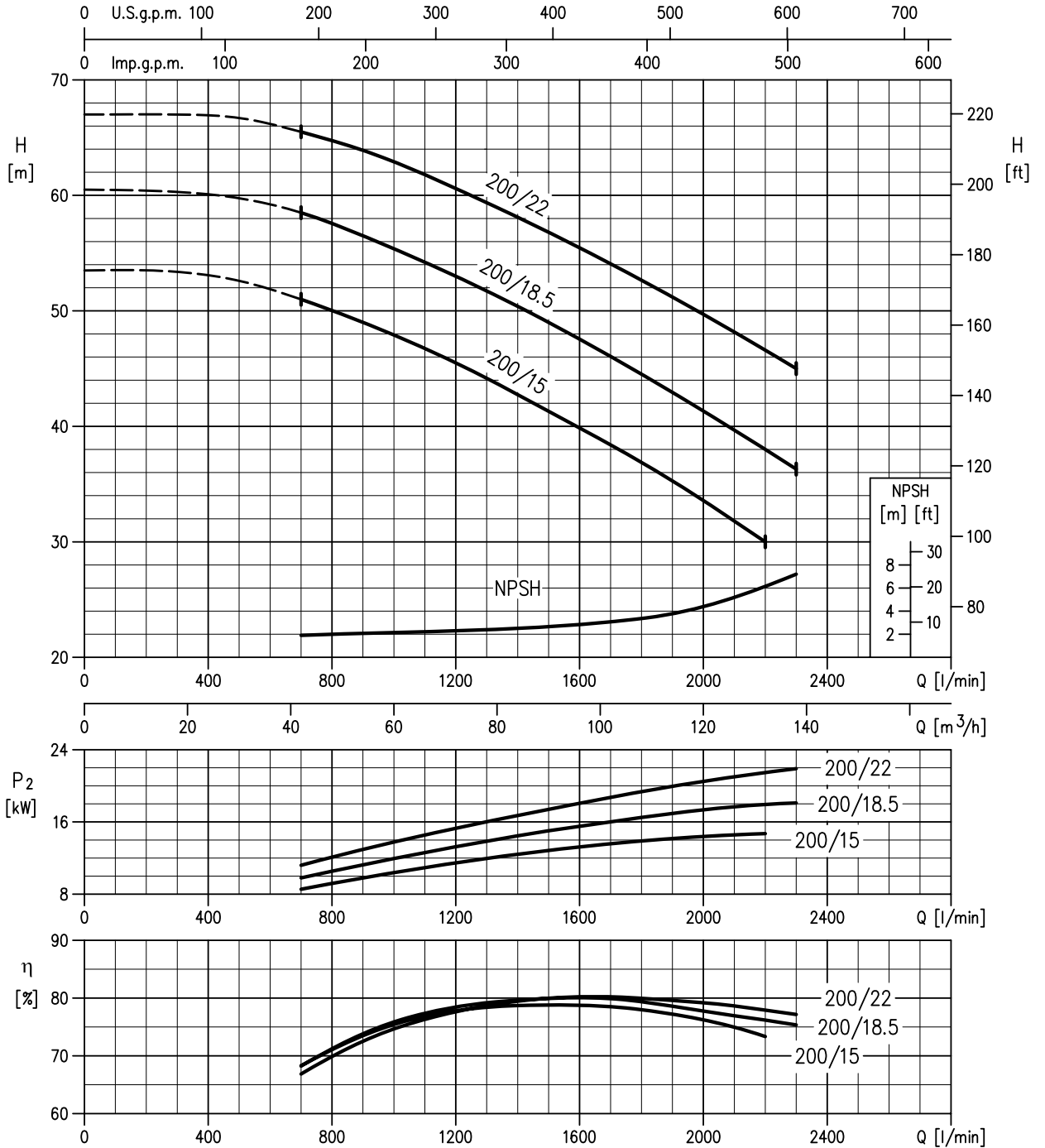

Rotation speed ≈ 2900 min⁻¹
 Test standard: ISO 9906:2012 - Grade 3B

65-250/30 (30kW) MEI > 0.70 – impeller diameter = 235 mm

65-250/37 (37kW) MEI > 0.70 – impeller diameter = 250 mm

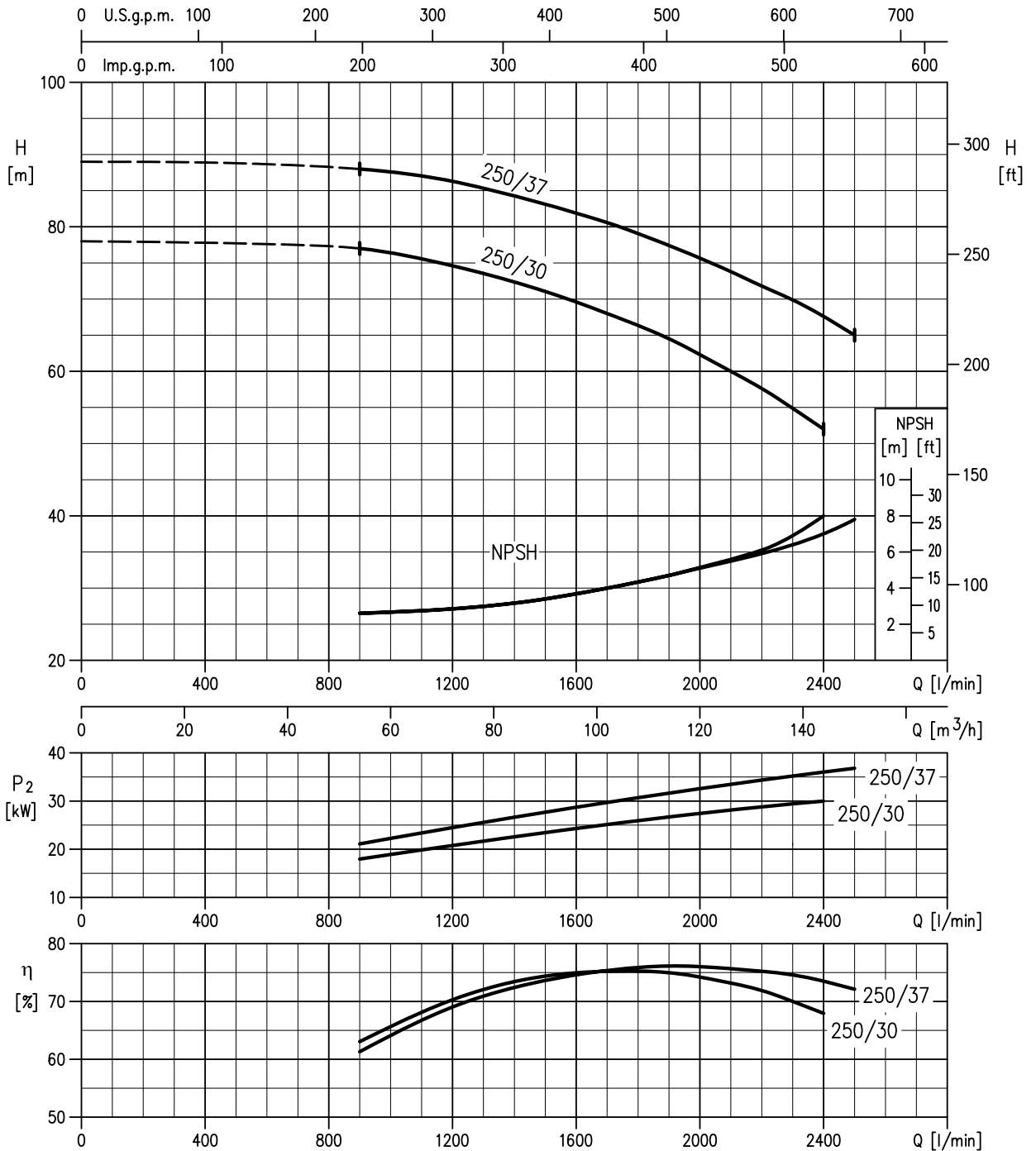

Rotation speed ≈ 2900 min⁻¹

Test standard: ISO 9906:2012 - Grade 3B

PERFORMANCE CURVE

50Hz

Rev. AC

80-160/11 (11kW) MEI > 0.70 – impeller diameter = 154 mm
 80-160/15R (15kW) MEI > 0.70 – impeller diameter = 160 mm
 80-160/15 (15kW) MEI > 0.70 – impeller diameter = 165 mm
 80-160/18.5 (18.5kW) MEI > 0.70 – impeller diameter = 174 mm

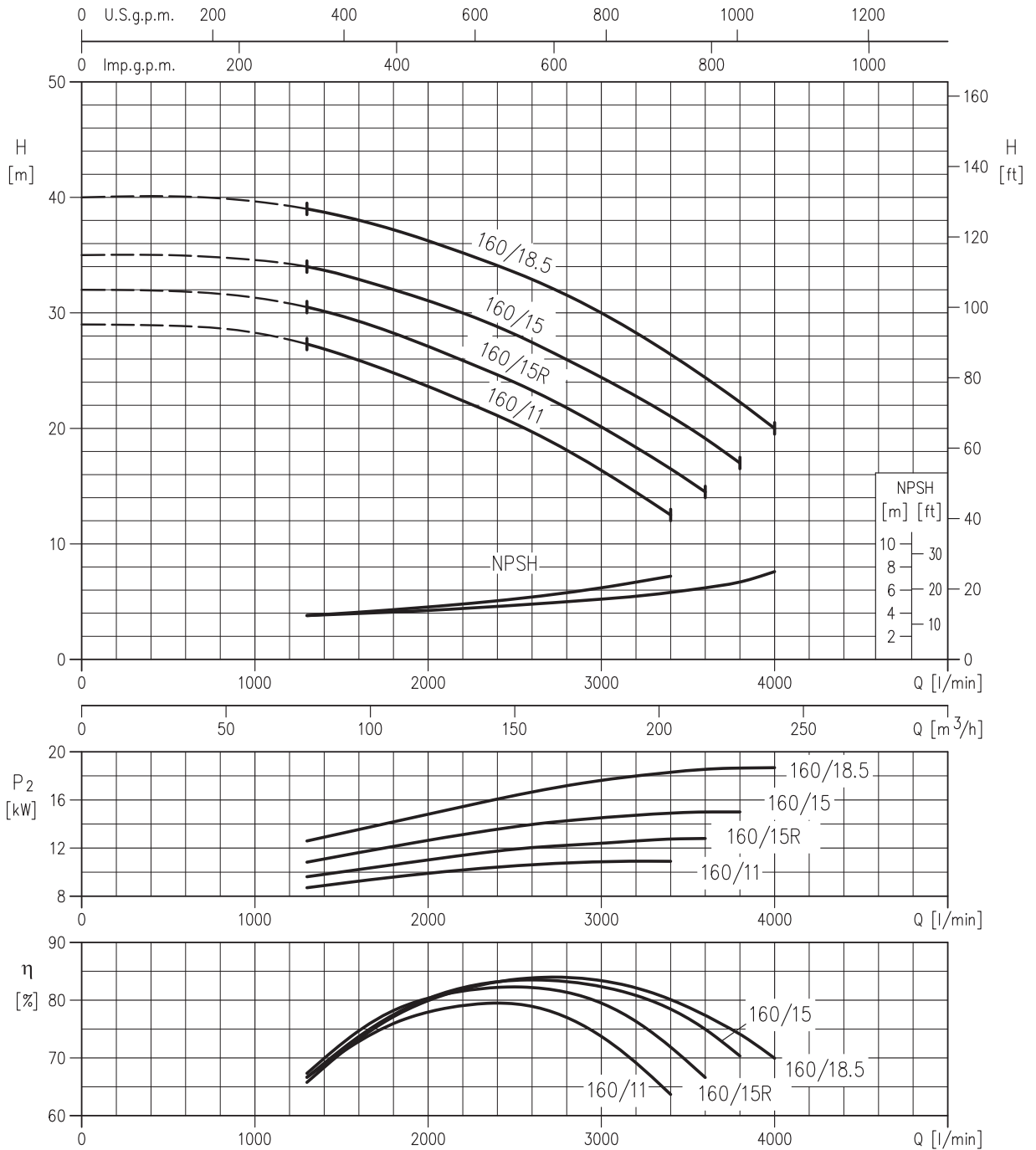

Rotation speed ≈ 2900 min⁻¹
 Test standard: ISO 9906:2012 - Grade 3B

80-200/22 (22kW) MEI > 0.60 – impeller diameter = 196 mm
 80-200/30 (30kW) MEI > 0.60 – impeller diameter = 211 mm
 80-200/37 (37kW) MEI > 0.60 – impeller diameter = 219 mm

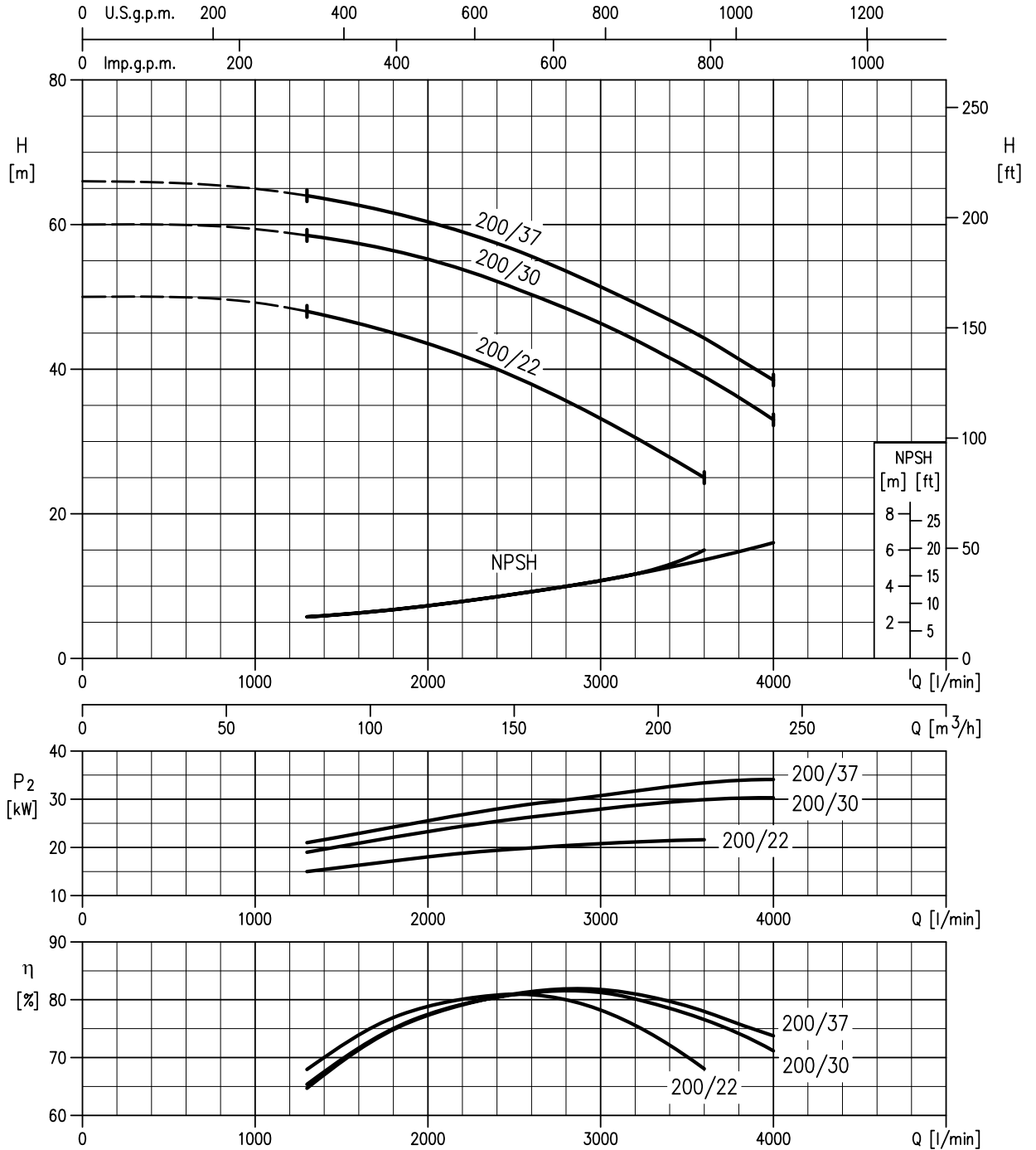

Rotation speed ≈ 2900 min⁻¹
 Test standard: ISO 9906:2012 - Grade 3B

PERFORMANCE CURVE

50Hz

Rev. AC

80-250/37 (37kW) MEI > 0.60 – impeller diameter = 230 mm
 80-250/45 (45kW) MEI > 0.60 – impeller diameter = 245 mm
 80-250/55 (55kW) MEI > 0.60 – impeller diameter = 259 mm

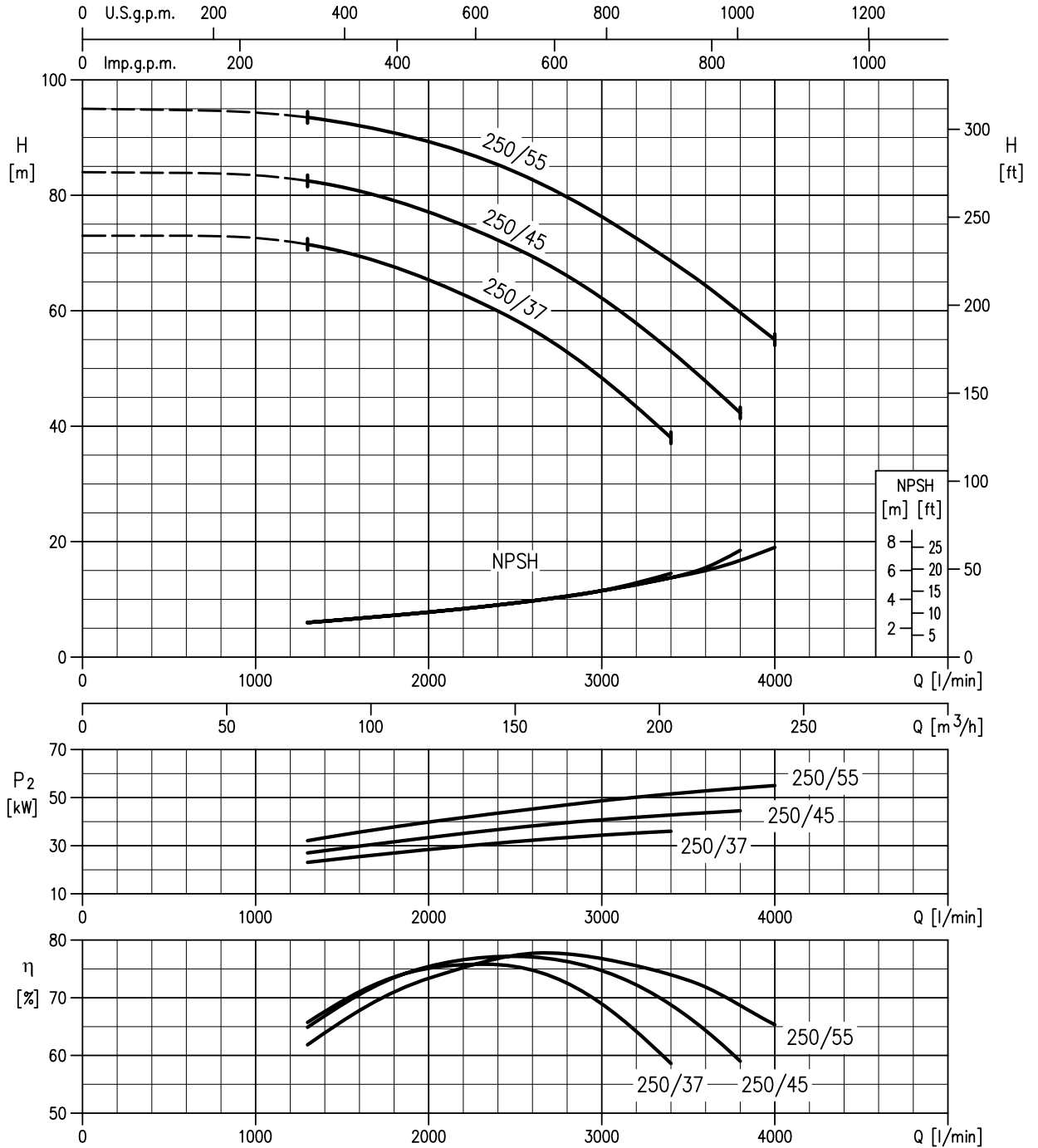

Rotation speed ≈ 2900 min⁻¹
 Test standard: ISO 9906:2012 - Grade 3B

SECTIONAL VIEW DRAWING 3(.)M 32, 40, 50, 65-125/160/200

UP TO 11 kW

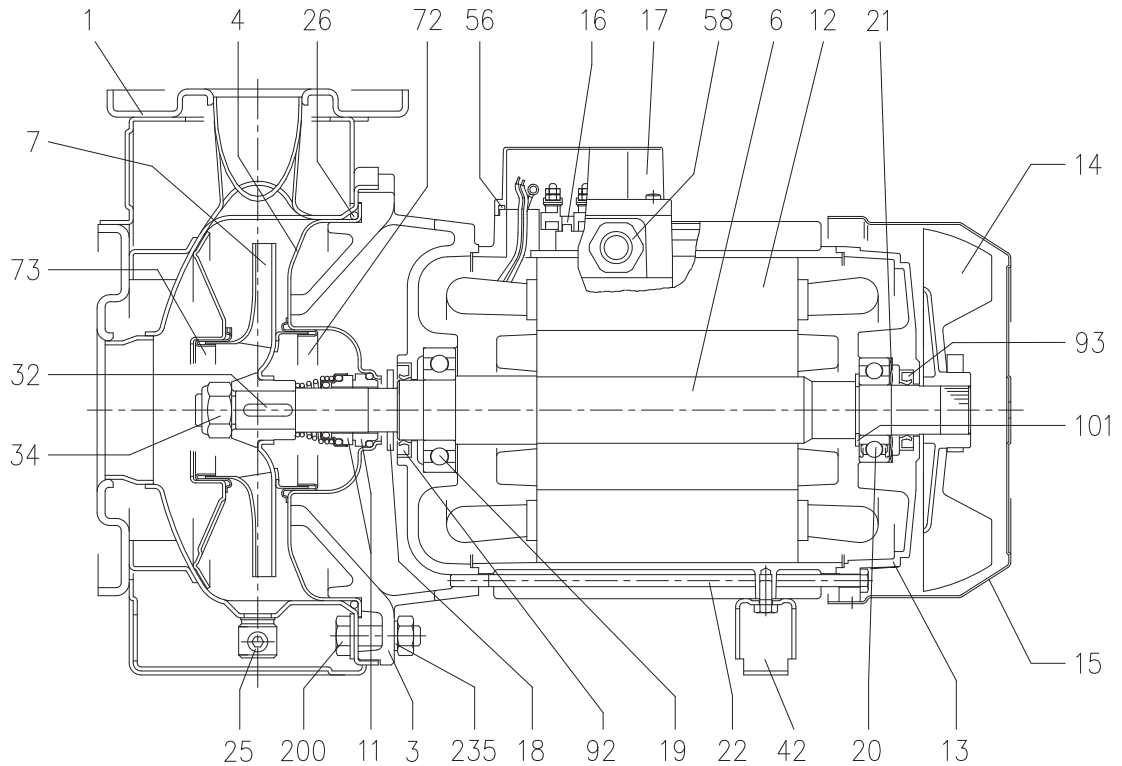

15 kW AND ABOVE

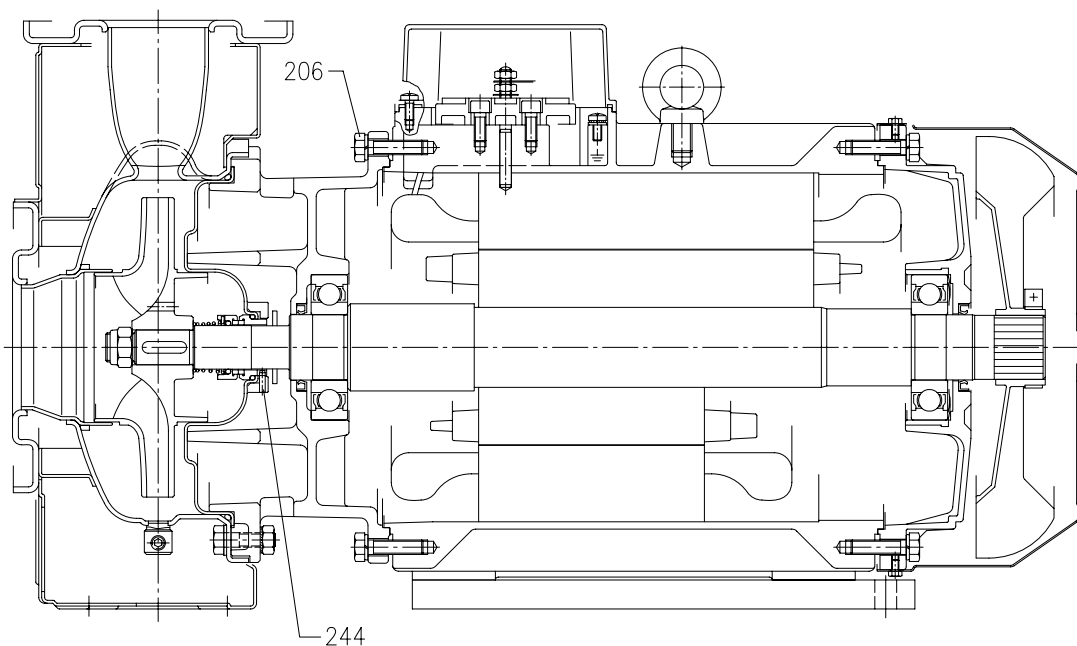

SECTIONAL VIEW TABLE 3(.)M 32, 40, 50, 65-125/160/200

N°	PART NAME	MATERIAL		DIMENSIONS	STANDARD	Q.TY	
		3M	3LM				
1	Casing	EN 1.4301 (AISI 304)	EN 1.4404 (AISI 316L)			1	
3	Motor bracket		[9]			1	
4	Casing cover	EN 1.4301 (AISI 304)	EN 1.4404 (AISI 316L)			1	
6	Shaft with rotor-Part in contact with liquid	EN 1.4301 (AISI 304)	EN 1.4404 (AISI 316L)			1	
7	Impeller	EN 1.4301 (AISI 304)[10]	EN 1.4404(AISI 316L)[10]			1	
11	Mechanical seal	Carbon/Ceramic/NBR	SiC/SiC/FPM	[8]		1	
12	Motor frame with stator	-				1	
13	Motor cover	Aluminium				1	
14	Fan	PA				1	
15	Fan cover	Fe P04 Galvanized				1	
16	Terminal	-				1	
17	Terminal box cover	Aluminium (three phase version)				1	
18	Splash ring	Up to 11 kW	/	40x21.5x3	EBARA DRAWING	1	
		15 kW and above		50x29.5x3			
19	Bearing	-		See table p.324		1	
20	Bearing	-		See table p.324		1	
21	Adjusting ring	Steel C70				1	
22	Tie rod	Up to 3 kW	Fe 42 Galvanized	M5	EBARA DRAWING	4	
		For 4 - 5.5 - 7.5 kW		M6			
		9.2 e 11kW		M8			
	Screw	15 kW and above	Galvanized Steel 8.8 strenght class ISO 898-1	M10x40	UNI 5739		
25	Draining plug	EN 1.4401 (AISI 316) / PTFE		R 1/8" L=8	DIN 906	1	
26	"O" ring	32-125, 40-125	NBR [7]	FPM	158.11x5.34	OR 6625	
		32-160, 40-160, 50-125			183.52x5.34	OR 6720	
		32-200, 40-200, 50-160, 50-200, 65-160, 65-200			227.96x5.34	OR 6895	
32	Key	Up to 11 kW	EN 1.4401 (AISI 316)		A 6x6x25	UNI 6604	1
		15 kW and above	A 8x7x30				
34	Impeller nut	Up to 11kW	EN 1.4301 (AISI 304)	EN 1.4404 (AISI 316L)	M16x1.5	UNI 7474	1
		50-200/15			M18x1.5		
		15 kW and above			M20x1.5		
42	Foot	Aluminium / Galvanized steel			EBARA DRAWING	[1]	
56	Box gasket	NBR				1	
58	Fastening nut	-				[2]	
72	Casing ring	[3]	EN 1.4301 (AISI 304)	EN 1.4404 (AISI 316L)		1	
73	Casing ring		EN 1.4301 (AISI 304)	EN 1.4404 (AISI 316L)		1	
92	Lip seal	Up to 3kW	-	-	25x40x7	DIN 3760 without spring	1
		From 4 to 7.5 kW			30x47x7		
		From 9.2 kW to 11 kW			40x55x7		
		From 15 kW to 22 kW			45x60x7		
93	Lip seal	Up to 4 kW	-	-	25x40x7	DIN 3760 without spring	1
		From 5.5 kW to 7.5 kW			30x47x7		
		From 9.2 kW to 11 kW			40x55x7		
		From 15 kW to 22 kW			45x60x7		
101	Snap ring (only 9.2 and 11kW)	Carbon tool steels TC 80		Ø 40	UNI 7435	1	
200	Screw	32-125, 40-125	Stainless steel A2 70 class ISO 3506/1		M 8x30	UNI 5739	8
		40-160, 40-200, 50-125, 50-160, 50-200, 65-125, 65-160, 65-200			M 10x35		
235	Washer	32-125, 40-125	EN 1.4301 (AISI 304)		8.4x17	UNI 6592	8
		40-160, 40-200, 50-125, 50-160, 50-200, 65-125, 65-160, 65-201			10.5x21		
206	Screw for bracket	[5]	Galvanized Steel 8.8 strenght class ISO 898-1		M 10x40	UNI 5739	4
244	Pin	[6]	-	EN 1.4301 (AISI 304)	4x15		1

Counterflange kit on request, see table p. 335-336

- [1] Quantity =0 for 65-160/15
Quantity =1 for 32-40-50 and 65 up to 11kW
Quantity =2 for 65-200/15, 65-200/18.5, 65-200/22
- [2] Quantity =1 up to 11kW
Quantity =2 from 15kW to 22kW
- [3] For version 32-200/3, 32-200/4, 32-200/5.5, 40-200/5.5, 40-200/7.5, 40-200/11, 50-160/5.5, 50-160/7.5, 50-200/9.2, 50-200/11, 50-200/15
- [4] Quantity =10 for 32-160, 40-160, 50-125, 65-125
Quantity =12 for 32-200, 40-200, 50-160, 50-200, 65-160, 65-200
- [5] For 15kW and above
- [6] Only for 65-160/15 and 65-200
- [7] FPM for H-HS-HW-HSW version
EPDM for E version, Q1AEGG, Q1Q1EGG, Q1U3EGG, U3CEGG, U3U3EGG
(U3U3EGG not available for 65-160/15 and 65-200)
- [8] Special version: see page 326 and following
- [9] Cast iron EN-GJL-200-EN 1561 for 32-200/3 and models with 15, 18.5, 22 kW motor
Aluminum AL-EN-1706-AC-46000-D for all the others.
- [10] CF8M – EN 1.4408 (AISI316) material for 65-125 up to 65-200

SECTIONAL VIEW DRAWING 3LMZ 32, 40, 50, 65-125/160/200

UP TO 11 kW

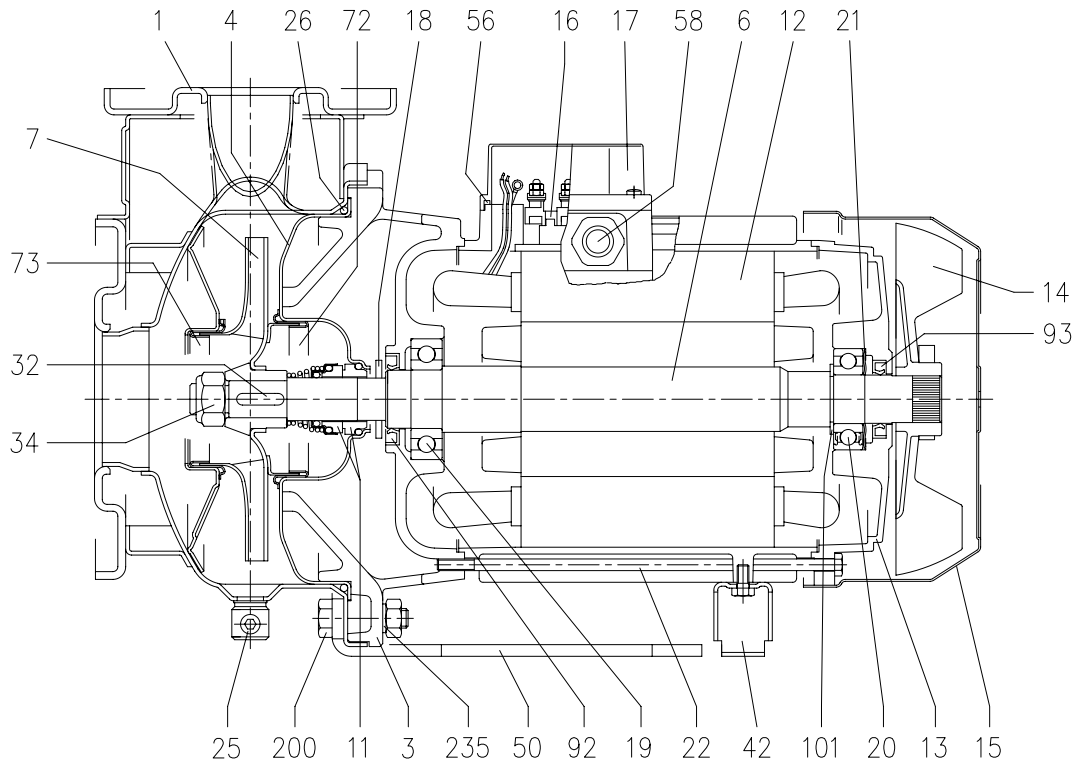

15 kW AND ABOVE

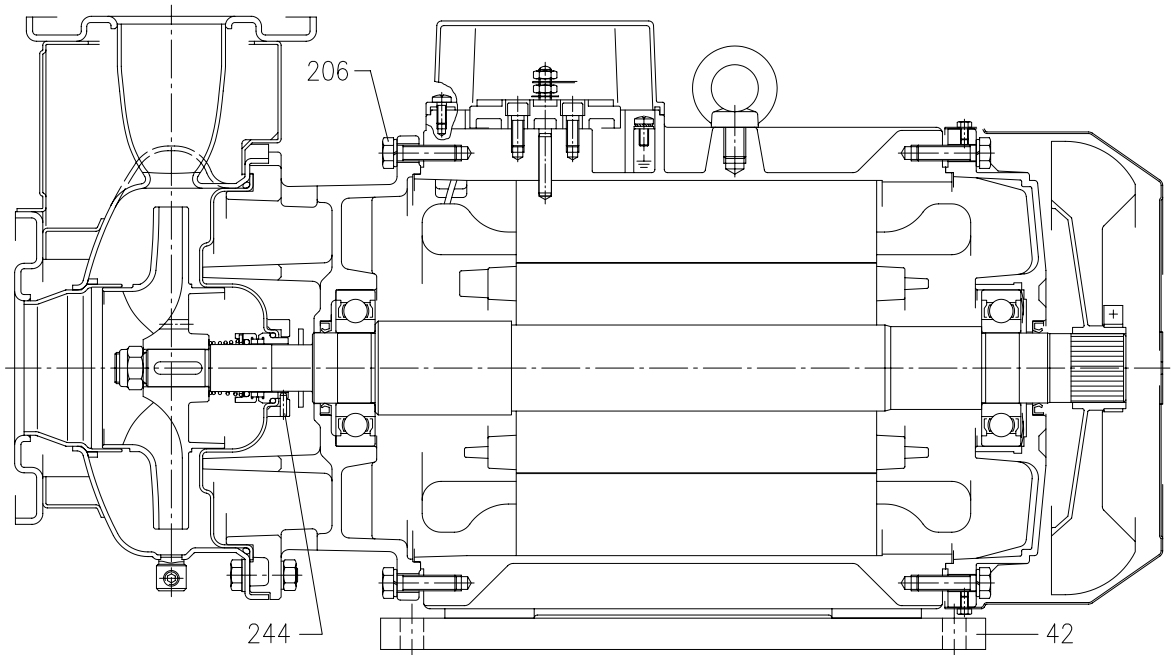

SECTIONAL VIEW TABLE 3LMZ 32, 40, 50, 65-125/160/200

N°	PART NAME	MATERIAL	DIMENSIONS	STANDARD	Q.TY
1	Casing	EN 1.4404 (AISI 316L)			1
3	Motor bracket	[8]			1
4	Casing cover	EN 1.4404 (AISI 316L)			1
6	Shaft with rotor-Part in contact with liquid	EN 1.4404 (AISI 316L)			1
7	Impeller	EN 1.4404 (AISI 316L) [9]			1
11	Mechanical seal	SiC/SiC/FPM	[7]		1
12	Motor frame with stator	-			1
13	Motor cover	Aluminium			1
14	Fan	PA			1
15	Fan cover	Fe P04 Galvanized			1
16	Terminal	-			1
17	Terminal box cover	Aluminium			1
18	Splash ring	Up to 11 kW 15 kW and above	/	40x21.5x3 50x29.5x3	EBARA DRAWING 1
19	Bearing	-	See table p. 324		1
20	Bearing	-	See table p. 324		1
21	Adjusting ring	Steel C70			1
22	Tie rod	Up to 3 kW For 4 - 5.5 - 7.5 kW 9.2 e 11kW	Fe 42 Galvanized	M5 M6 M8	EBARA DRAWING 4
	Screw	15 kW and above	Galvanized Steel 8.8	M10x40	UNI 5739
25	Draining plug		AISI 316 / PTFE	R 1/8" L=8	DIN 906
26	"O" ring	32-125, 40-125 32-160, 40-160, 50-125, 65-160 32-200, 40-200, 50-160, 50-200, 65-160, 65-200	FPM	158.11x5.34 183.52x5.34 227.96x5.34	OR 6625 OR 6720 OR 6895
32	Key	Up to 11 kW 15 kW and above	EN 1.4401 (AISI 316)	A 6x6x25 A 8x7x30	UNI 6604
34	Impeller nut	Up to 11kW 50-200/15 15 kW and above	EN 1.4404 (AISI 316L)	M16x1.5 M18x1.5 M20x1.5	UNI 7474
42	Foot		Al / Galvanized steel		EBARA DRAWING [1]
50	Casing foot (only from 1.1 kW to 11 kW)		Galvanized steel		1
56	Box gasket		NBR		1
58	Fastening nut		-		[2]
72	Casing ring	[3]	EN 1.4404 (AISI 316L)		1
73	Casing ring		EN 1.4404 (AISI 316L)		1
92	Lip seal	Up to 3kW From 4 to 7.5 kW From 9.2 kW to 11 kW From 15 kW to 22 kW	-	25x40x7 30x47x7 40x55x7 45x60x7	DIN 3760 without spring
93	Lip seal	Up to 4 kW From 5.5 kW to 7.5 kW From 9.2 kW to 11 kW From 15 kW to 22 kW	-	25x40x7 30x47x7 40x55x7 45x60x7	DIN 3760 without spring
101	Snap ring (only 9.2 and 11kW)		Carbon tool steels TC 80	Ø 40	UNI 7435
200	Screw	32-125, 40-125 40-160, 40-200, 50-125, 50-160, 50-200, 65-125, 65-160, 65-200	Stainless steel A2 70 class ISO 3506/1	M8 M10	UNI 5739 [4]
235	Washer	32-125, 40-125 40-160, 40-200, 50-125, 50-160, 50-200, 65-125, 65-160, 65-201	EN 1.4301 (AISI 304)	8.4x17 10.5x21	UNI 6592 [4]
206	Screw for bracket	[5]	Galvanized Steel 8.8	M 10x40	UNI 5739
244	Pin	[6]	EN 1.4301 (AISI 304)	4x15	1

Counterflange kit on request, see table p. 335-336

[1] Quantity =0 for 50-200/15 and 65-160/15

Quantity =1 for 32-200/7.5, 40-200/7.5/11, 50-160/7.5, 50-200/9.2/11, 65-125/7.5, 65-160/7.5/9.2/11

Quantity =2 for 65-200/15/18.5/22

[2] Quantity =1 up to 11kW

Quantity =2 from 15kW to 22kW

[3] For version 32-200/3/4/5.5, 40-200/5.5/7.5/11, 50-160/5.5/7.5, 50-200/9.2/11/15

[4] Quantity =10 for 32-160, 40-160, 50-125, 65-125

Quantity =12 for 32-200, 40-200, 50-160, 50-200, 65-160, 65-200

[5] For 15kW and above

[6] Only for 65-160/15 and 65-200

[7] Special version: see page 326 and following

[8] Cast iron EN-GJL-200-EN 1561 for 32-200/3 and models with 15, 18.5, 22 kW motor

Aluminium AL-EN-1706-AC-46000-D for all the others.

[9] CF8M – EN 1.4408 (AISI316) material for 65-125 up to 65-200

SECTIONAL VIEW DRAWING 3LM 80-160/11

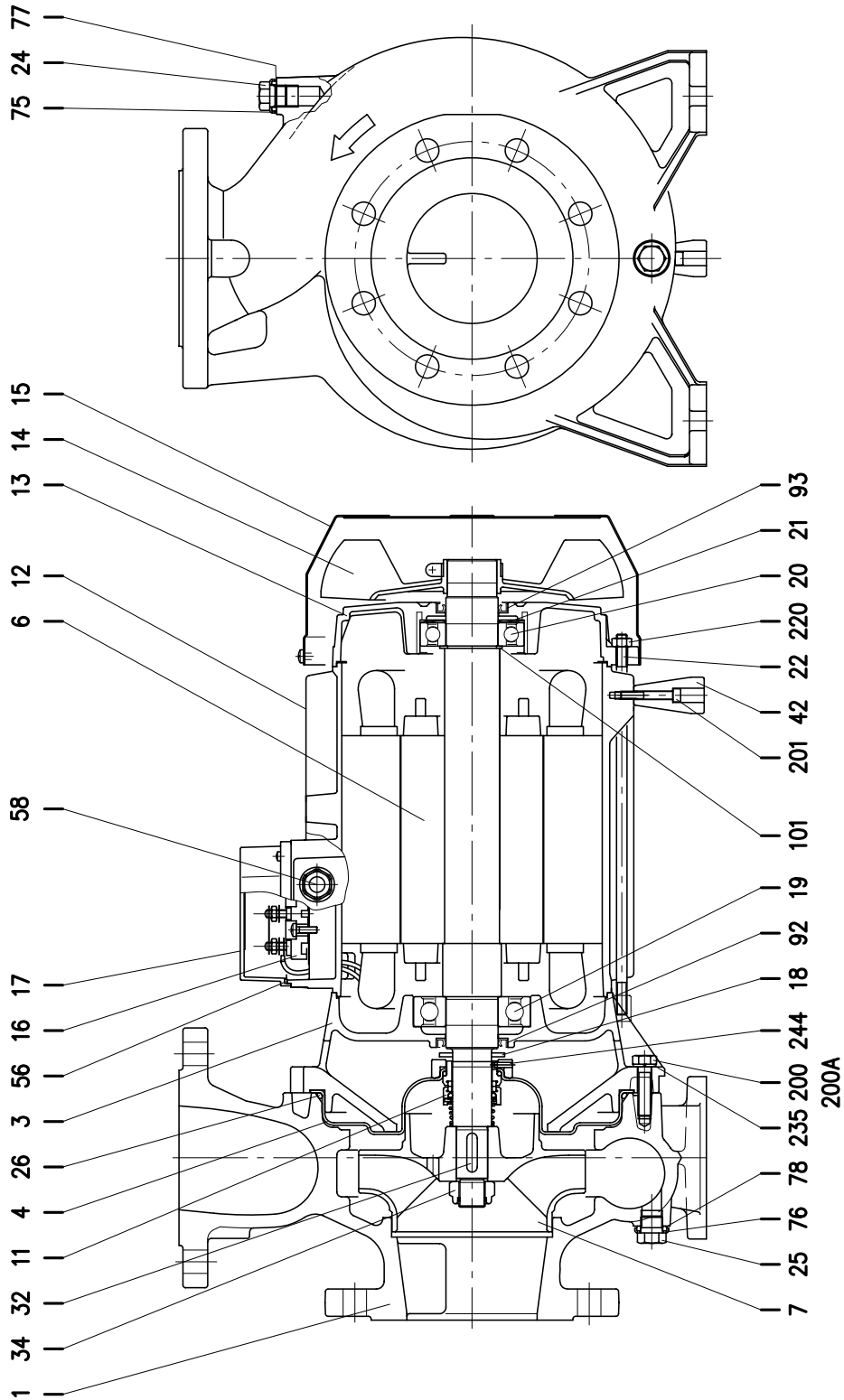

SECTIONAL VIEW DRAWING 3LM 80-160/15R/15/18.5

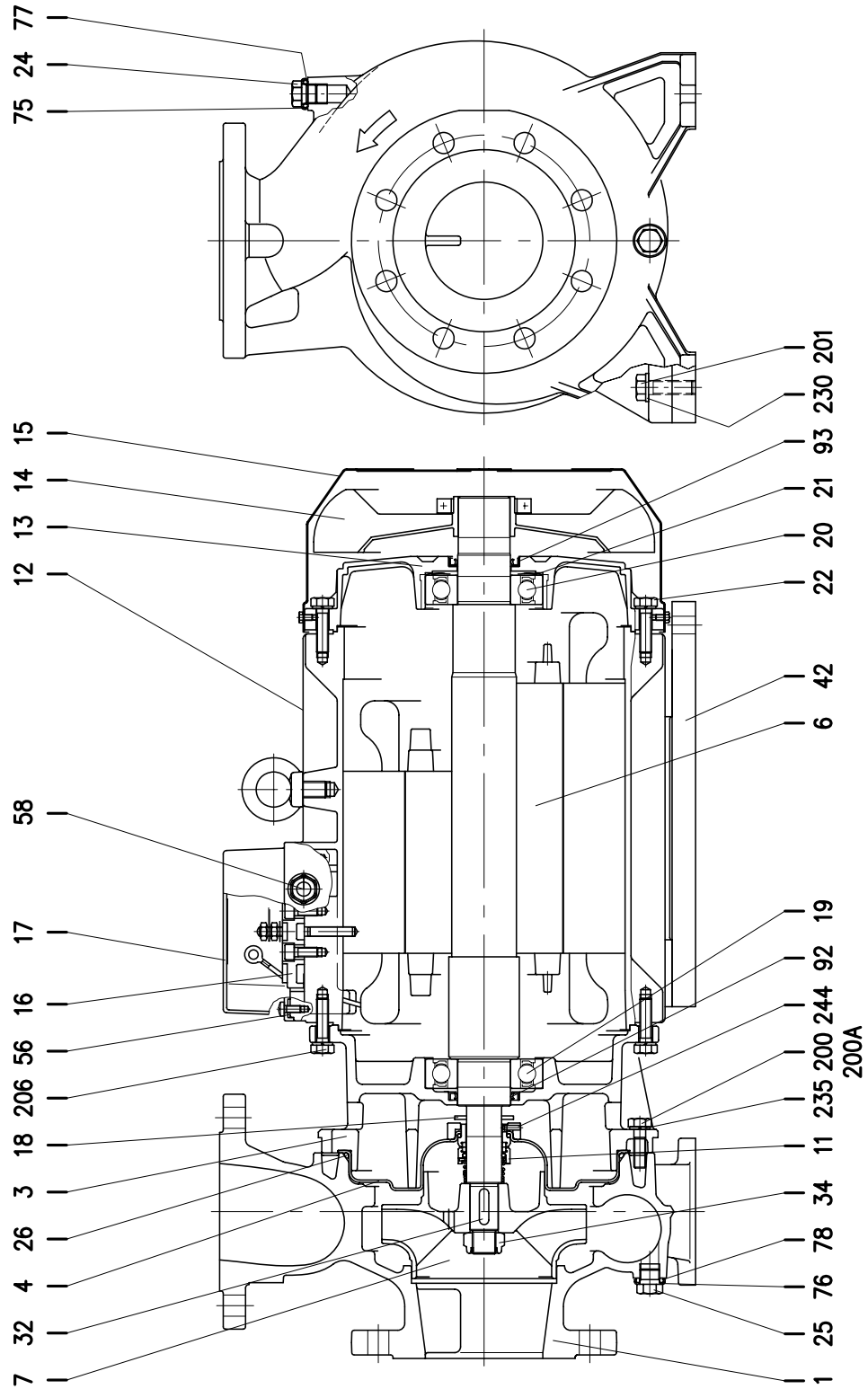

SECTIONAL VIEW TABLE 3LM 80-160

N°	PART NAME	MATERIAL	DIMENSIONS	STANDARD	Q.TY
1	Casing	CF8M - EN 1.4408 (AISI 316)			1
3	Motor bracket	Cast iron EN-GJL-200-EN 1561			1
4	Casing cover	EN 1.4404 (AISI 316L)			1
6	Shaft with rotor	EN 1.4404(AISI 316L) - Wet extension			1
7	Impeller	CF8M - EN 1.4408 (AISI 316)			1
11	Mechanical seal	SiC/SiC/FPM	[5]		1
12	Motor frame with stator	-			1
13	Motor cover	Aluminium			1
14	Fan	PA			1
15	Fan cover	Fe P04 Galvanized			1
16	Terminal	-			1
17	Terminal box cover	Aluminium			1
18	Splash ring	NBR	50x29.5x3	EPE DRAWING	1
19	Bearing	-	See table p. 324		1
20	Bearing	-	See table p. 324		1
21	Adjusting ring	Steel C70			1
22	Screw	Galvanized Steel 8.8 strenght class ISO 898/1		EPE DRAWING	4
24	Plug	EN 1.4404 (AISI 316L)	G 3/8	EPE DRAWING	1
25	Plug	EN 1.4404 (AISI 316L)	G 3/8	EPE DRAWING	1
26	"O" ring	FPM	227.96x5.34	OR 6895	1
32	Key	EN 1.4404 (AISI 316L)	8x7x30	UNI 6604	1
34	Impeller nut	Aluminium	M20x1.5	UNI 7474	1
42	Foot	Aluminium		EPE DRAWING	[1]
56	Box gasket	NBR			1
58	Fasting nut	-			[2]
75	Washer (plug)	EN 1.4404 (AISI 316L)			1
76	Washer (plug)				1
77	O-ring (plug)				1
78	O-ring (plug)	FPM [4]			1
92	Lip seal	-	40x55x7	DIN 3760	1
	11 kW				
	15 - 18.5 kW		45x60x7	without spring	1
93	Lip seal	-	40x55x7	DIN 3760	1
	11 kW				
	15 - 18.5 kW		45x60x7	without spring	1
101	Snap ring (only 11 kW)	Carbon tool steels TC 80	Ø 40	UNI 7435	1
200	Screw		M 10x35		10
200 A	Screw	Stainless steel A2-70 class ISO 3506/1	M 10x30	UNI 5739	2
201	Screw		M 6x40		1
	11 kW	Stainless steel A2-70 class ISO 3506/1	M 12x40	UNI 5739	4
	15 - 18.5 kW				
206	Screw for bracket (only 15 - 18.5 kW)	Galvanized steel 8.8 strenght class ISO 898/1	M 10x40	UNI 5739	4
220	Nut for tie rod (only 11 kW)	Galvanized steel	M10		4
230	Washer	-	-	-	-
	11 kW				
	15 - 18.5 kW	Galvanized steel	13x24x2.5	UNI 6592	4
235	Washer	EN 1.4301(AISI 304)	10.5	UNI 6592	12
244	Pin	EN 1.4301(AISI 304)	4x15		1

Counterflange kit on request, see p. 335-336

- [1] Quantity =1 for version 80-160/11
Quantity =2 for version 80-160/15R, 80-160/15 and 80-160/18.5
- [2] Quantity =1 for version 80-160/11
Quantity =2 for version 80-160/15R, 80-160/15 and 80-160/18.5
- [3] Not for H and E version
- [4] FPM for H, HW, HSW version
EPDM for E version, Q1AEGG, Q1Q1EGG, Q1U3EGG, U3CEGG
- [5] Special version: see page 326 and following

SECTIONAL VIEW DRAWING 3(.)S 32, 40, 50

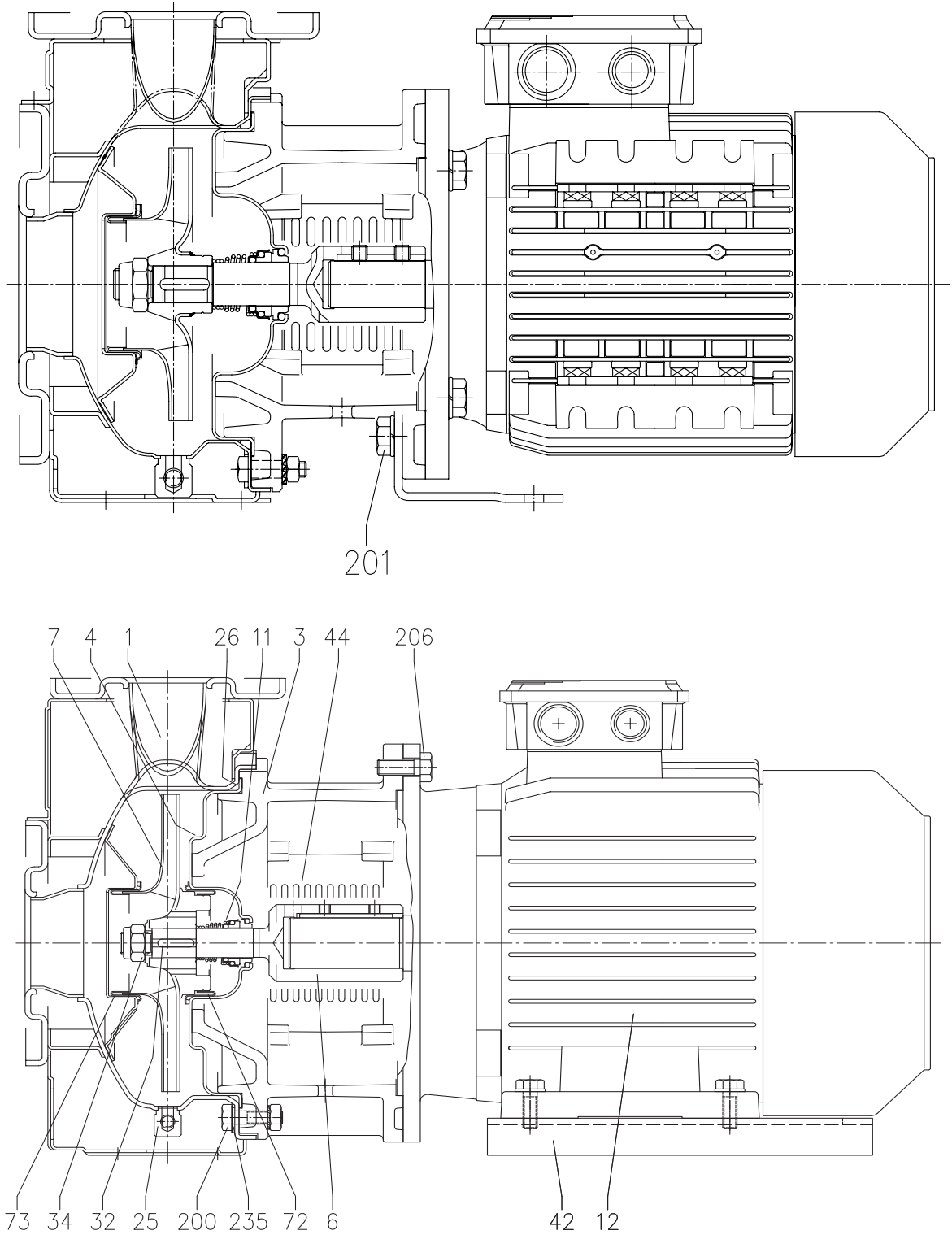

SECTIONAL VIEW DRAWING 3(.)S 65-125/160/200

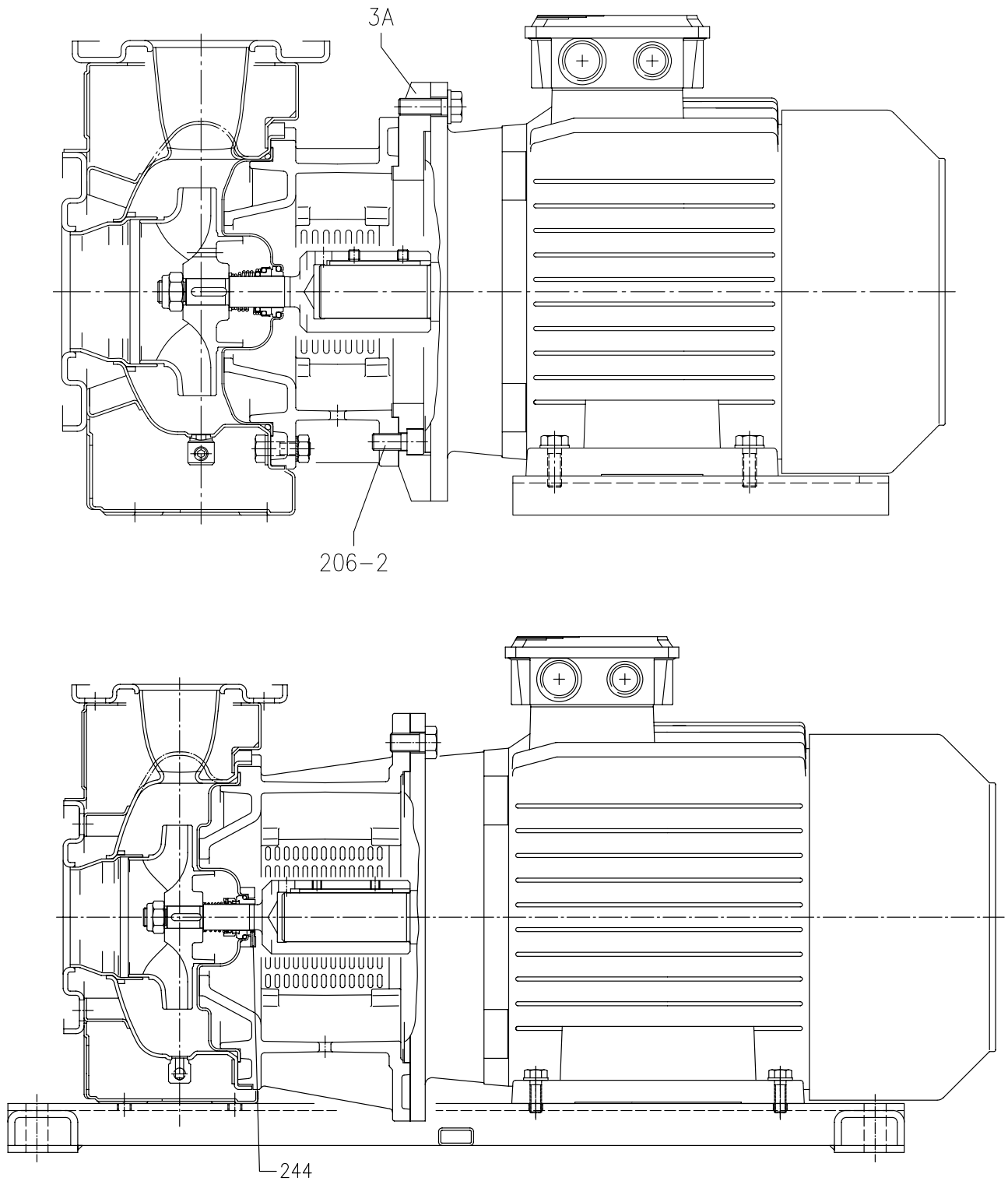

SECTIONAL VIEW TABLE 3(.)S 32, 40, 50, 65-125/160/200

N°	PART NAME	MATERIAL		DIMENSIONS	STANDARD	Q.TY	
		3S	3LS				
1	Casing	EN 1.4301 (AISI 304)	EN 1.4404 (AISI 316L)			1	
3	Motor bracket	Cast iron EN-GJL-200-EN 1561				1	
3 A	Adapter ring [1]	Cast iron EN-GJL-200-EN 1561				1	
4	Casing cover	EN 1.4301 (AISI 304)	EN 1.4404 (AISI 316L)			1	
6	Coupling - Part in contact with liquid	EN 1.4301 (AISI 304)	EN 1.4404 (AISI 316L)	See table p. 333		1	
7	Impeller	EN 1.4301 (AISI 304)	EN 1.4404 (AISI 316L) [9]			1	
11	Mechanical seal	Carbon/Ceramic/NBR	SiC/SiC/FPM	[7]		1	
12	Motor	-				1	
25	Draining plug	EN 1.4401 (AISI 316) / PTFE		R 1/8" L=8	DIN 906	1	
26	"O" ring	NBR [8]	FPM	32-125, 40-125	158.11x5.34	OR 6625	1
				32-160, 40-160, 50-125, 65-125	183.52x5.34	OR 6720	
				32-200, 40-200, 50-160, 50-200, 65-160, 65-200	227.96x5.34	OR 6895	
32	Key	Up to 11 kW	EN 1.4401 (AISI 316)	15 kW and above	6x6x25	UNI 6604	1
					8x7x30		
34	Impeller nut	EN 1.4301 (AISI 304)	EN 1.4404 (AISI 316L)	Up to 11kW	M16x1.5	UNI 7474	1
				50-200/15	M18x1.5		
				15 kW and above	M20x1.5		
42	Foot	Aluminium / Galvanized steel				[2]	
44	Protection	EN 1.4301 (AISI 304)			EBARA DRAWING	1	
72	Casing ring [3]	EN 1.4301 (AISI 304)	EN 1.4404 (AISI 316L)			1	
73	Casing ring (not for 65 version)	EN 1.4301 (AISI 304)	EN 1.4404 (AISI 316L)			1	
200	Screw	32-125, 40-125	Stainless steel A2 70 class ISO 3506/1	50-200, 65-125, 65-160, 65-200	M 8x30	UNI 5739	8
					M 10x35	UNI 5739	[4]
201	Screw	Galvanized Steel 8.8 strenght class ISO 898/1		M 10x16	UNI 5739	[5]	
206	Screw for bracket	Galvanized Steel 8.8 strenght class ISO 898/1		M 10x40	UNI 5739	4	
206-2	Screw adapter ring [1]	Galvanized Steel 8.8 strenght class ISO 898/1			UNI 5931	4	
235	Washer	32-125, 40-125	Stainless steel A2 70 class ISO 3506/1	50-200, 65-125, 65-160, 65-200	M 8.4x17	UNI 6592	8
					M 10.5x21	UNI 6592	[4]
244	Pin [6]	-	EN 1.4301 (AISI 304)		UNI 5931	4	

Counterflange kit on request see p. 335-336

- [1] Only for version 65-125/5.5 and 65-125/7.5
- [2] Quantity =0 for version 65-200/22
Quantity =1 for version for 32, 40, 50, 65-125/5.5, 65-125/7.5, 65-160/11, 65-160/15, 65-200/15, 65-200/18.5
Quantity =2 for version for 65-125/4, 65-160/7.5, 65-160/9.2
- [3] Only for version 32-200, 40-200, 50-160, 50-200
- [4] Quantity =10 for 32-160, 40-160, 50-125, 65-125
Quantity =12 for 32-200, 40-200, 50-160, 50-200, 65-160, 65-200
- [5] Only for version 32-125/1.1, 32-160/1.5, 32-160/1.5, 32-160/2.2, 40-125/1.5, 40-125/2.2, 50-125/2.2
- [6] Only for 65-160/15, 65-200
- [7] Special version: see page 326 and following
- [8] FPM for H-HS-HW-HSW version
EPDM for E version, Q1AEGG, U3U3EGG, Q1Q1EGG, Q1U3EGG, U3CEGG)
U3U3EGG not available for 65-150/15 and 65-200
- [9] CF8M – EN 1.4408 (AISI316) material for 65-125 up to 65-200

SECTIONAL VIEW DRAWING 3LSZ 32, 40-125/160, 40-200/5.5/7.5
50-125/160, 50-200/9.2, 65-125, 65-160/7.5/9.2

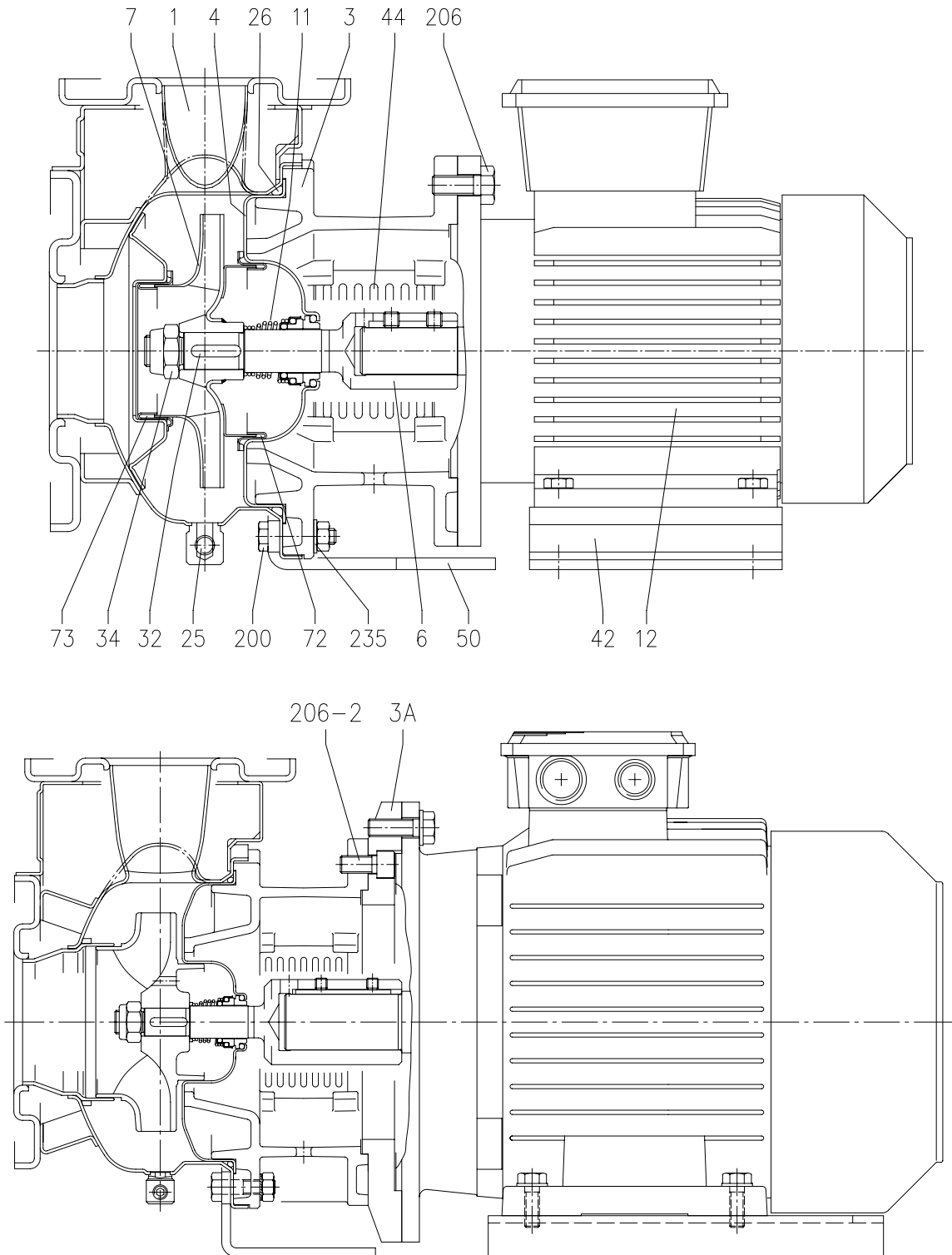

SECTIONAL VIEW DRAWING 3LSZ 40-200/11, 50-200/11/15, 65-160/11/15, 62-200

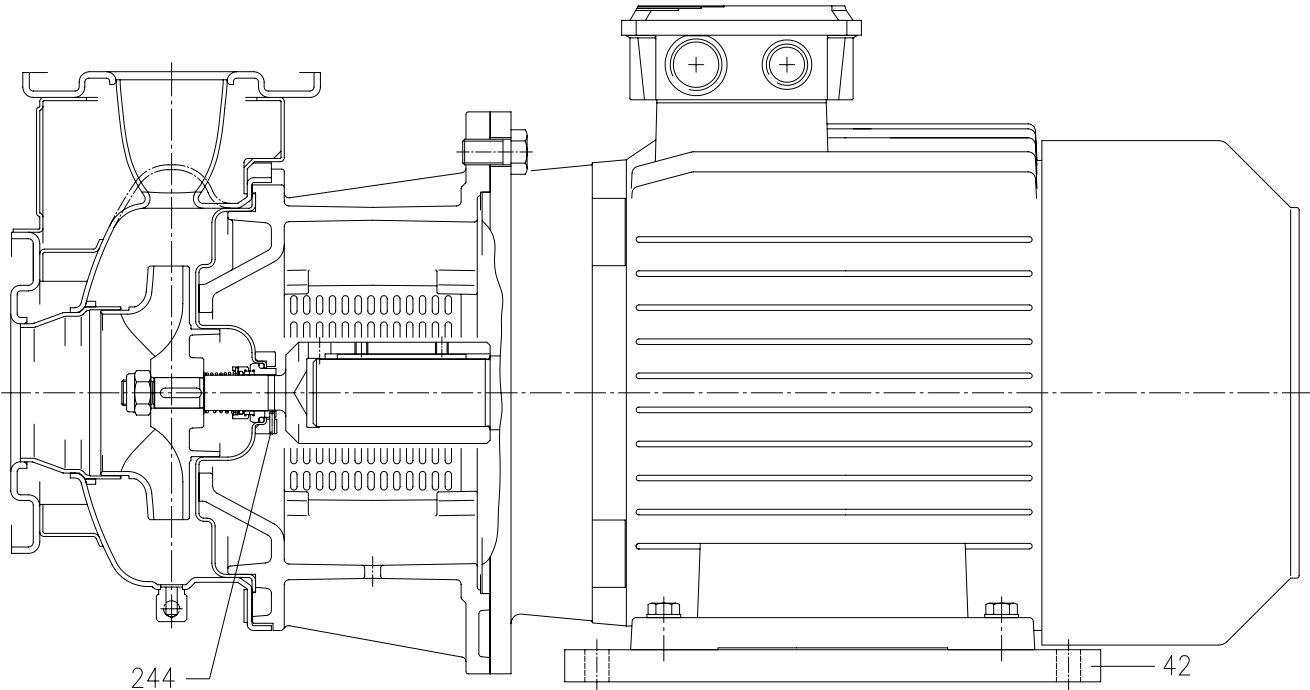

SECTIONAL VIEW TABLE 3LSZ 32, 40, 50, 65-125/160/200

N°	PART NAME	MATERIAL	DIMENSIONS	STANDARD	Q.TY	
1	Casing	EN 1.4404 (AISI 316L)			1	
3	Motor bracket	Cast iron EN-GJL-200-EN 1561			1	
3 A	Adapter ring [1]	Cast iron EN-GJL-200-EN 1561			1	
4	Casing cover	EN 1.4404 (AISI 316L)			1	
6	Coupling - Part in contact with liquid	EN 1.4404 (AISI 316L)	See table p. 333		1	
7	Impeller	EN 1.4404 (AISI 316L) [9]			1	
11	Mechanical seal	SiC/SiC/FPM	[7]		1	
12	Motor	-			1	
25	Draining plug	EN 1.4401 (AISI 316) / PTFE	R 1/8" L=8	DIN 906	1	
26	"O" ring	FPM	32-125, 40-125	158.11x5.34	OR 6625	1
			32-160, 40-160, 50-125, 65-125	183.52x5.34	OR 6720	
			32-200, 40-200,50-160, 50-200, 65-160, 65-200	227.96x5.34	OR 6895	
32	Key	EN 1.4401 (AISI 316)	Up to 11 kW	6x6x25	UNI 6604	1
			15 kW and above	8x7x30		
34	Impeller nut	EN 1.4404 (AISI 316L)	Up to 11kW	M16x1.5	UNI 7474	1
			50-200/15	M18x1.5		
			15 kW and above	M20x1.5		
42	Foot	Aluminium / Galvanized steel			[2]	
44	Protection	EN 1.4301 (AISI 304)		EBARA DRAWING	1	
50	Casing foot (only from 1.1 kW to 9.2 kW)	Galvanized Steel			1	
72	Casing ring [3]	EN 1.4404 (AISI 316L)			1	
73	Casing ring	EN 1.4404 (AISI 316L)			1	
200	Screw	Stainless steel A2 70 class ISO 3506/1	32-125, 40-125	M 8x30	UNI 5739	8
			50-200, 65-125, 65-160, 65-200	M 10x35	UNI 5739	[4]
201	Screw	Galvanized Steel 8.8	M 10x16	UNI 5739	[5]	
206	Screw for bracket	Galvanized Steel 8.8	M 10x40	UNI 5739	4	
206-2	Screw adapter ring [1]	Galvanized Steel 8.8		UNI 5931	4	
235	Washer	Stainless steel A2 70 class ISO 3506/1	32-125, 40-125	M 8.4x17	UNI 6592	8
			50-200, 65-125, 65-160, 65-200	M 10.5x21	UNI 6592	[4]
244	Pin [6]	EN 1.4301 (AISI 304)		UNI 5931	4	

Counterflange kit on request see p. 335-336

[1] Only for version 65-125/5.5/7.5

[2] Quantity =0 for version 65-200/22

Quantity =1 for version for 32-125/160, 50-125/2.2

Quantity =2 for version for 32-200, 40-125/160/200, 50-125/3/4, 50-160/200, 65-125, 65-160, 65-200/15/18.5

[3] Only for version 32-200, 40-200, 50-160, 50-200

[4] Quantity =10 for 32-160, 40-160, 50-125, 65-125

Quantity =12 for 32-200, 40-200, 50-160, 50-200, 65-160, 65-200

[5] Only for version 32-125/1.1, 32-160/1.5, 32-160/1.5, 32-160/2.2, 40-125/1.5, 40-125/2.2, 50-125/2.2

[6] Only for 65-160/15, 65-200

[7] Special version: see page 326 and following

[8] FPM for H-HS-HW-HSW version

EPDM for E version, U3U3EGG, Q1Q1EGG, Q1U3EGG, Q1AEGG, U3CEGG

U3U3EGG not available for 65-150/15 and 65-200

[9] CF8M – EN 1.4408 (AISI316) material for 65-125 up to 65-200

SECTIONAL VIEW DRAWING 3LS 80-160

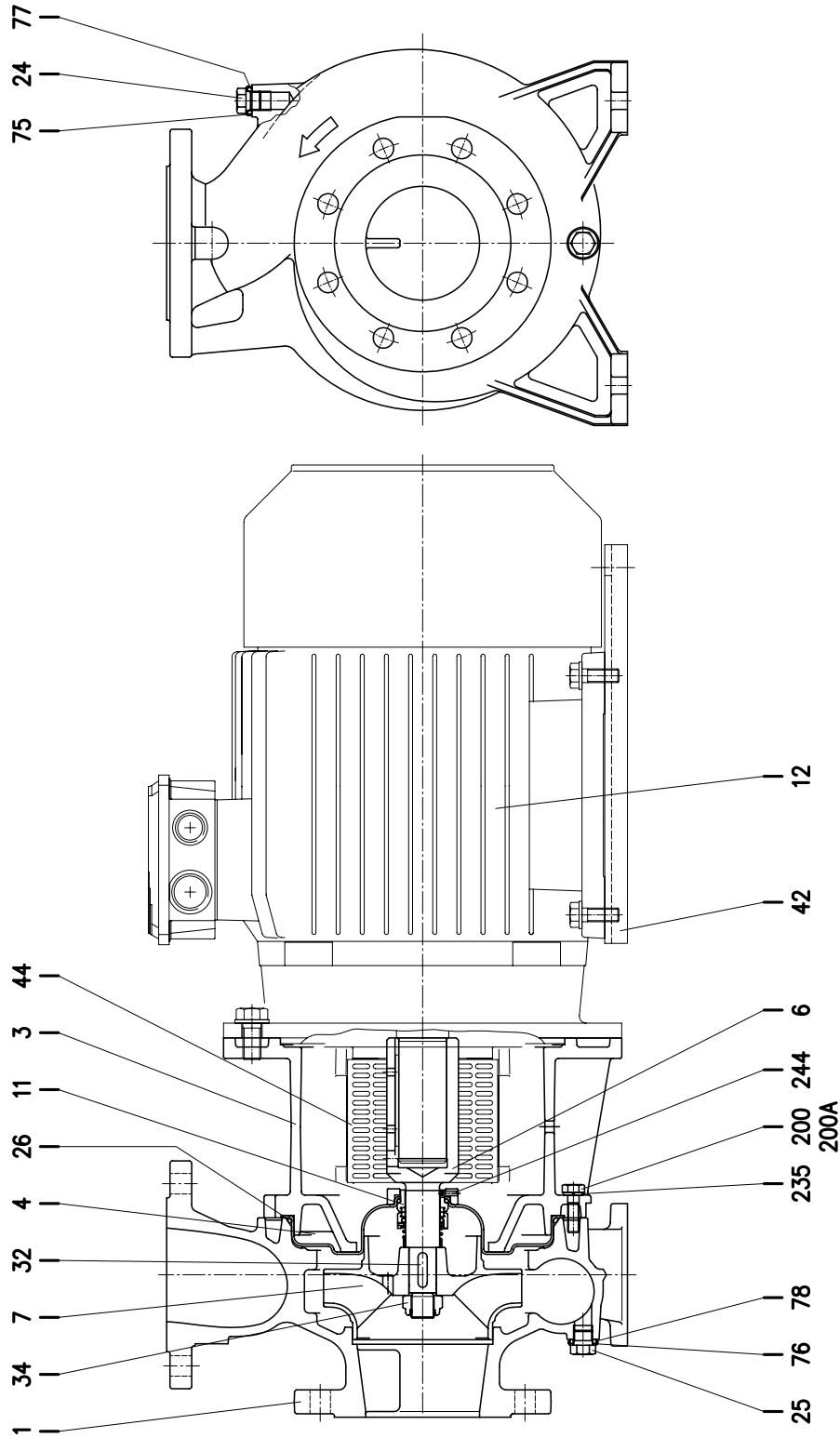

SECTIONAL VIEW TABLE 3LS 80-160

N°	PART NAME	MATERIAL	DIMENSIONS	STANDARD
1	Casing	CF8M-EN 1.4408 (AISI 316)		
3	Motor bracket	Cast iron EN-GJL-200-EN 1561		
4	Casing cover	EN 1.4404 (AISI 316L)		
6	Coupling	EN 1.4404 (AISI 316L)	See table p. 333	
7	Impeller	CF8M-EN 1.4408 (AISI 316)		
11	Mechanical seal	SiC/SiC/FPM	[3]	
12	Motor	-		
24	Plug	EN 1.4404 (AISI 316L)	G3/8	EPE DRAWING
25	Plug	EN 1.4404 (AISI 316L)	G3/8	EPE DRAWING
26	"O" ring	FPM [2]	227.96x5.34	OR 6895
32	Key	EN 1.4401 (AISI 316)	8x7x30	UNI 6604
34	Impeller nut	EN 1.4404 (AISI 316L)	M 20x1.5	UNI 7474
42	Foot	Aluminium		EPE DRAWING
44	Protection	EN 1.4301 (AISI 304)		EPE DRAWING
75	Washer (plug)	EN 1.4404 (AISI 316L)		
76	Washer (plug)			
77	O-ring (plug)	FPM [2]		
78	O-ring (plug)			
200	Screw	Stainless steel A2-70 class ISO 3506/1	M 10x35	UNI 5739
200 A	Screw		M 10x30	
235	Washer	EN 1.4301(AISI 304)	10.5x21	UNI 6592
244	Pin [1]	EN 1.4301(AISI 304)	4x15	

Counterflange kit on request see p. 335-336

[1] Not for H and E version.

[2] FPM for H, HW, HSW version

EPDM for E version and Special Seals (Q1AEGG, Q1Q1EGG, U3CEGG, Q1U3EGG)

[3] Special version: see page 326 and following

SECTIONAL VIEW DRAWING 3LS 65-250, 80-200/250

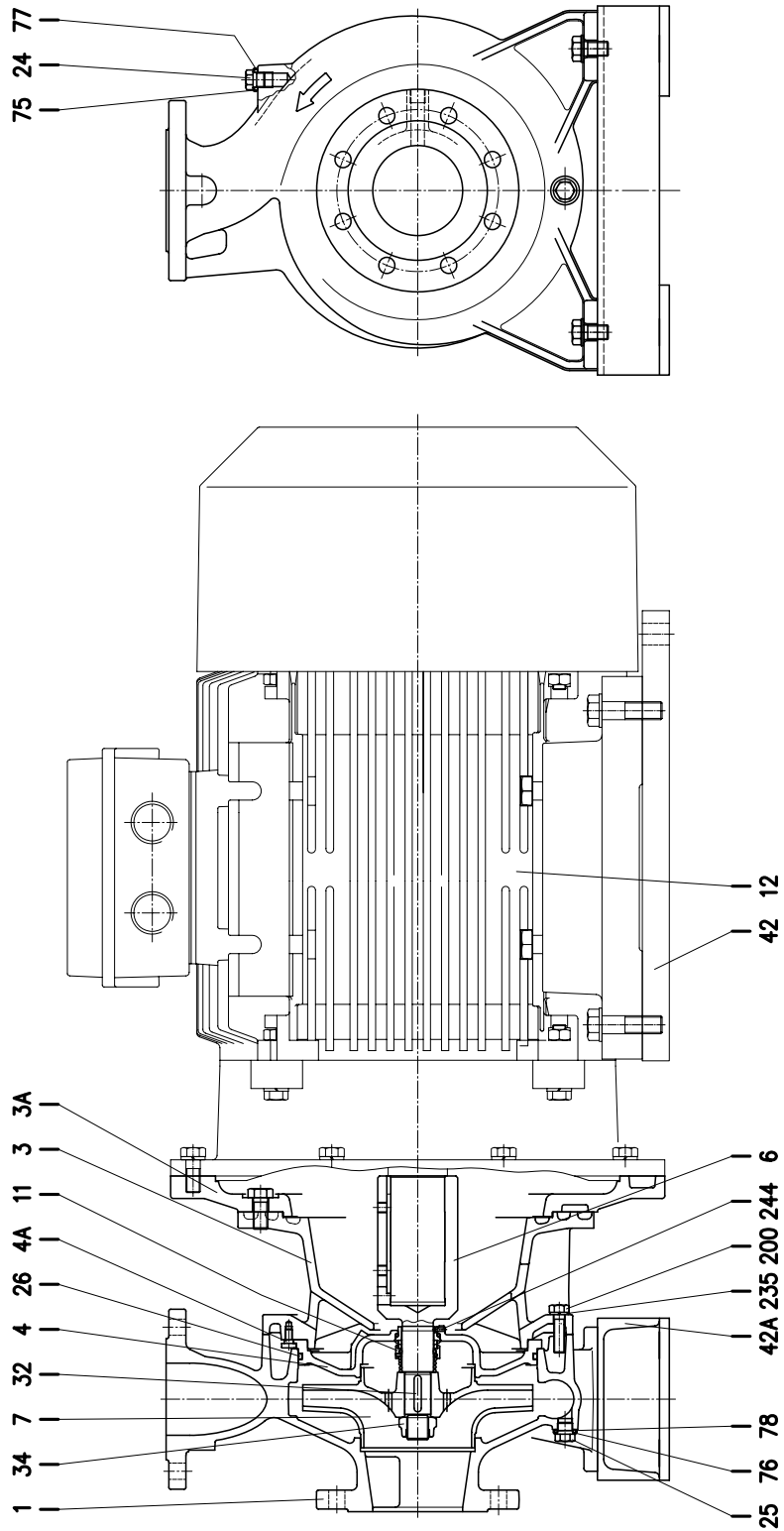

CONSTRUCTION

50Hz

Rev. AC

SECTIONAL VIEW TABLE 3LS 65-250, 80-200/250

N°	PART NAME		MATERIAL	DIMENSIONS	STANDARD	Q.TY
1	Casing		CF8M-EN 1.4408 (AISI 316)			1
3	Motor bracket		Cast iron EN-GJL-200-EN 1561			1
3 A	Adapter ring		Cast iron EN-GJL-200-EN 1561			[1]
4	Casing cover		EN 1.4401 (AISI 316)			1
4 A	Screw for casing cover		EN 1.4301(AISI 304)			2
6	Coupling	65-250	d=24 mm	EN 1.4404 (AISI 316L) for 22 kW	See table p. 333	1
				EN 1.4462 (Duplex stainless steel) for 30-37 kW		1
		80-200	d=24 mm	EN 1.4404 (AISI 316L) for 22 kW		1
				EN 1.4462 (Duplex stainless steel) for 30-37 kW		1
	80-250	d=29 mm	EN 1.4462 (Duplex stainless steel)		1	
7	Impeller		CF8M-EN 1.4408 (AISI 316)			1
11	Mechanical seal		SiC/SiC/FPM	[6]		1
12	Motor		-			1
24	Plug		EN 1.4404 (AISI 316L)	G3/8	EPE DRAWING	1
25	Plug		EN 1.4404 (AISI 316L)	G3/8	EPE DRAWING	1
26	"O" ring		FPM [5]	253.36x5.34	OR 6995	1
32	Key	65-250	d=24 mm	EN 1.4401 (AISI 316)	8x7x30	UNI 6604
			80-200			
		80-250	d=29 mm			
34	impeller nut	65-250	d=24 mm	EN 1.4404 (AISI 316L)	M20x1.5	UNI 7474
			80-200			
		85-250	d=29 mm			
42	Foot for motor		Aluminium			[2]
42 A	Foot for pump		Aluminium/Galvanized steel (only for 80-250/55)		EPE DRAWING	[3]
75	Washer (plug)		EN 1.4404 (AISI 316L)			1
76	Washer (plug)					1
77	O-ring (plug)		FPM [5]			1
78	O-ring (plug)					1
200	Screw		Stainless steel A2-70 class ISO 3506/1	M 12x45	UNI 5739	10
235	Washer		C70	13	UNI 1751	10
244	Pin [4]		EN 1.4301(AISI 304)	4x12		1

Counterflange kit on request, see table p. 335-336

[1] Only for 65-250/37 , 80-200/37 , 80-250/37 – 80-250/45 and 80-250/55

[2] Quantity =2 for 80-250/55

[3] Quantity =2 for 80-200/30 , 80-200/37 , 80-250/45

Quantity =1 for 80-250/55

[4] Not for H and E version

[5] FPM for H, HW, HSW version

EPDM for E version and Special seals Q1Q1EGG, Q1U3EGG, U3CEGG, Q1AEGG (Not for model 80-250)

EPDM for ES version only model 80-250

[6] Special version: see page 326 and following

SECTIONAL VIEW DRAWING 3(.)P 32, 40, 50, 65-125/160/200

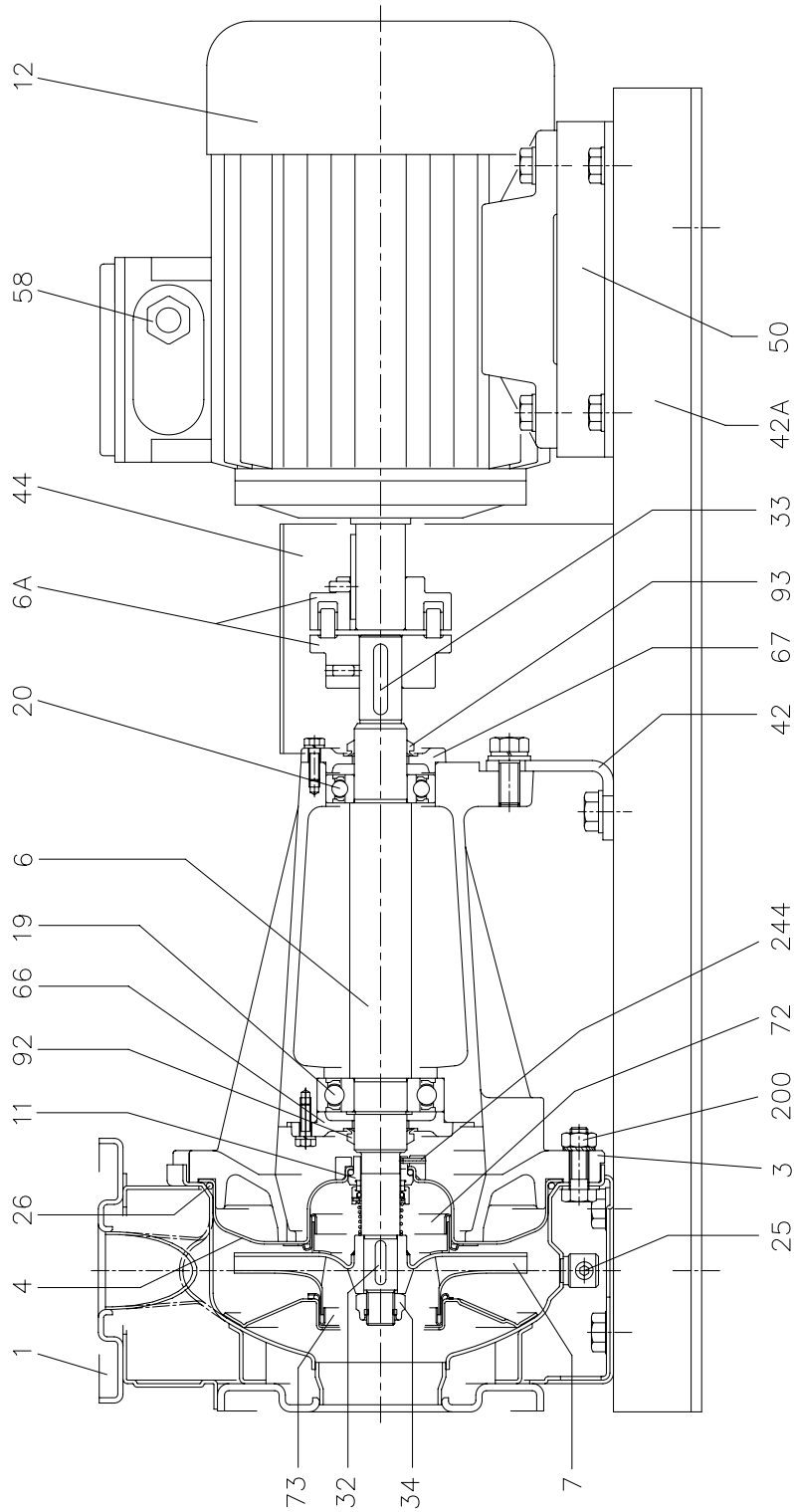

SECTIONAL VIEW TABLE 3(.)P 32, 40, 50, 65-125/160/200

N°	PART NAME	MATERIAL		DIMENSIONS	STANDARD	
		3P	3LP			
1	Casing	EN 1.4301 (AISI 304)	EN 1.4404 (AISI 316L)			
3	Support	Cast iron EN-GJL-200-EN 1561				
4	Casing cover	EN 1.4301 (AISI 304)	EN 1.4404 (AISI 316L)			
6	Shaft - Part in contact with liquid	EN 1.4301 (AISI 304)	EN 1.4404 (AISI 316L)			
6 A	Flexible coupling	Cast iron EN-GJL-250-EN 1561		See table pag. 334		
7	Impeller	EN 1.4301 (AISI 304)	EN 1.4404 (AISI 316L) [6]			
11	Mechanical seal	Carbon/Ceramic/NBR	SiC/SiC/FPM	[5]		
12	Motor					
19	Bearing			See table p. 325		
20	Bearing			See table p. 325		
25	Draing plug	EN 1.4401 (AISI 316) / PTFE		R 1/8" L=8	DIN 906	
26	"O" ring	32-125, 40-125 32-160, 40-160, 50-125, 65-125 32-200, 40-200, 50-160, 50-200, 65-160, 65-200	NBR [4]	FPM	158.11x5.34	OR 6625
					183.52x5.34	OR 6720
					227.96x5.34	OR 6895
32	Key	Up to 11 kW 15 kW and above	EN 1.4401 (AISI 316)		6x6x25 8x7x30 UNI 6604	
33	Key		C 40		8x7x40 UNI 6604	
34	Impeller nut	Up to 11kW 50-200/15 15 kW and above	EN 1.4301 (AISI 304)	EN 1.4404 (AISI 316L)	M16x1.5	UNI 7474
					M18x1.5	
					M20x1.5	
42	Pump support	Fe 37 Galvanized			EBARA DRAWING	
42 A	Base	Fe 37 Galvanized				
44	Protection	Fe 37 Galvanized				
50	Foot	Aluminium / Galvanized steel				
58	Fasting nut					
66	Impeller side bearing cover	Cast iron EN-GJL-200-EN 1561				
67	Motor side bearing cover	Cast iron EN-GJL-200-EN 1561				
72	Casing ring	[1] EN 1.4301 (AISI 304)	EN 1.4404 (AISI 316L)			
73	Casing ring (not for 65 version)	EN 1.4301 (AISI 304)	EN 1.4404 (AISI 316L)			
92	"V" ring			VS - 0030		
93	"V" ring			VS - 0030		
200	Screw	32-125, 40-125 40-160, 40-200, 50-125, 50-160, 50-200, 65-125, 65-160, 65-200	Stainless steel A2 70 class ISO 3506/1		M 8x30	UNI 5739
					M 10x35	UNI 5739
244	Pin	[3]	/	EN 1.4301 (AISI 304)	4x15	

Counterflange kit on request see p. 335-336

- [1] For version: 32-200/3, 32-200/4, 32-200/5.5, 40-200/5.5, 40-200/7.5, 40-200/11, 50-160/5.5, 50-160/7.5, 50-200/9.2, 50-200/11, 50-200/15
- [2] Quantity =10 for 32-160, 40-160, 50-125, 65-125
Quantity =12 for 32-200, 40-200, 50-160, 50-200, 65-160, 65-200
- [3] Only for 65-160/15 and 65-200
- [4] FPM for H-HS-HW-HSW version
EPDM for E version and Special Seals Q1Q1EGG, Q1U3EGG, U3CEGG, Q1AEGG, U3U3EGG
U3U3EGG is not available for model 65-160/15 and model 65-200
- [5] Special version: see page 326 and following
- [6] CF8M – EN 1.4408 (AISI316) material for 65-125 up to 65-200

SECTIONAL VIEW DRAWING 3LP 80-160

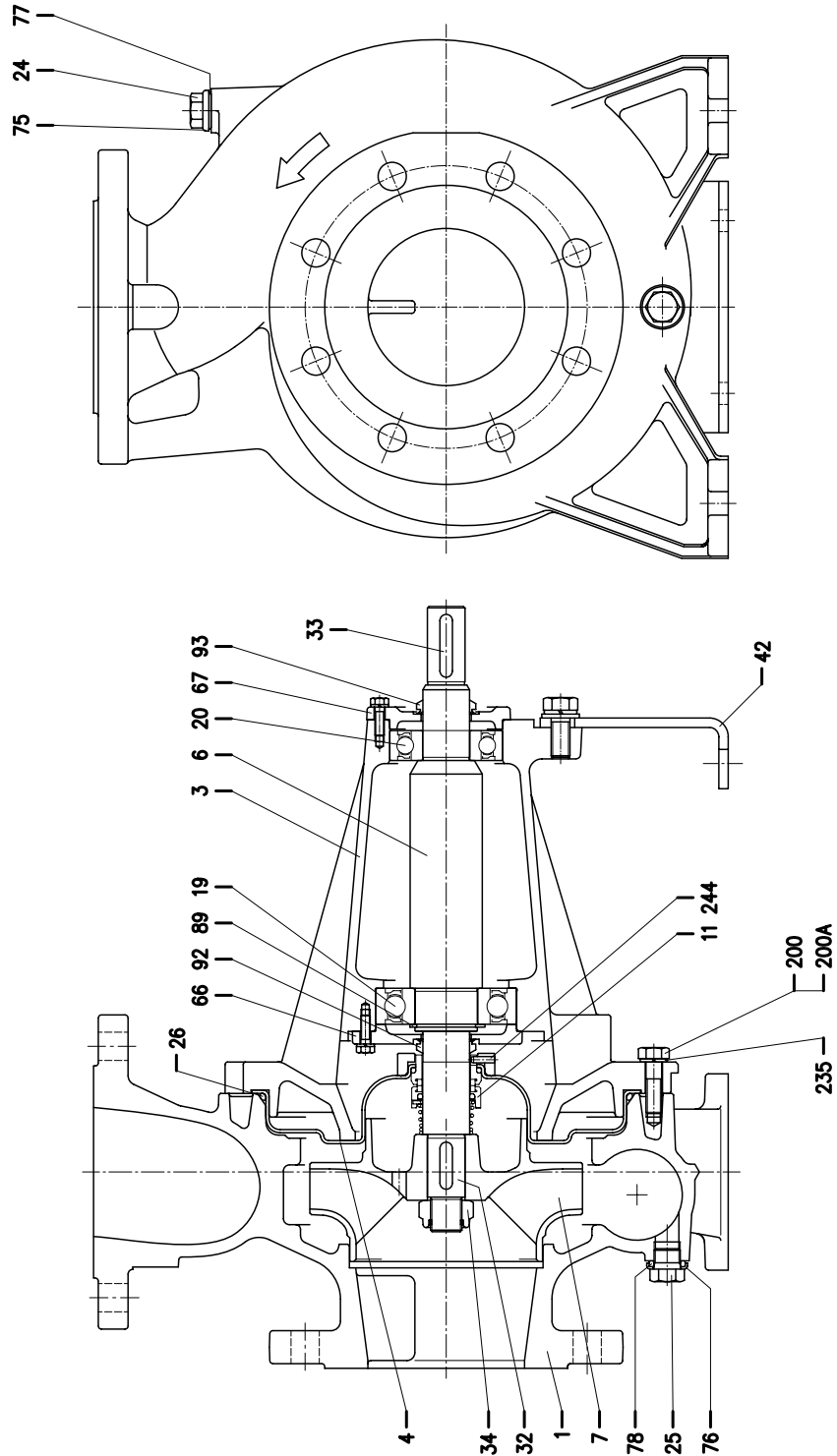

SECTIONAL VIEW DRAWING 3LP 65-250, 80-200/250

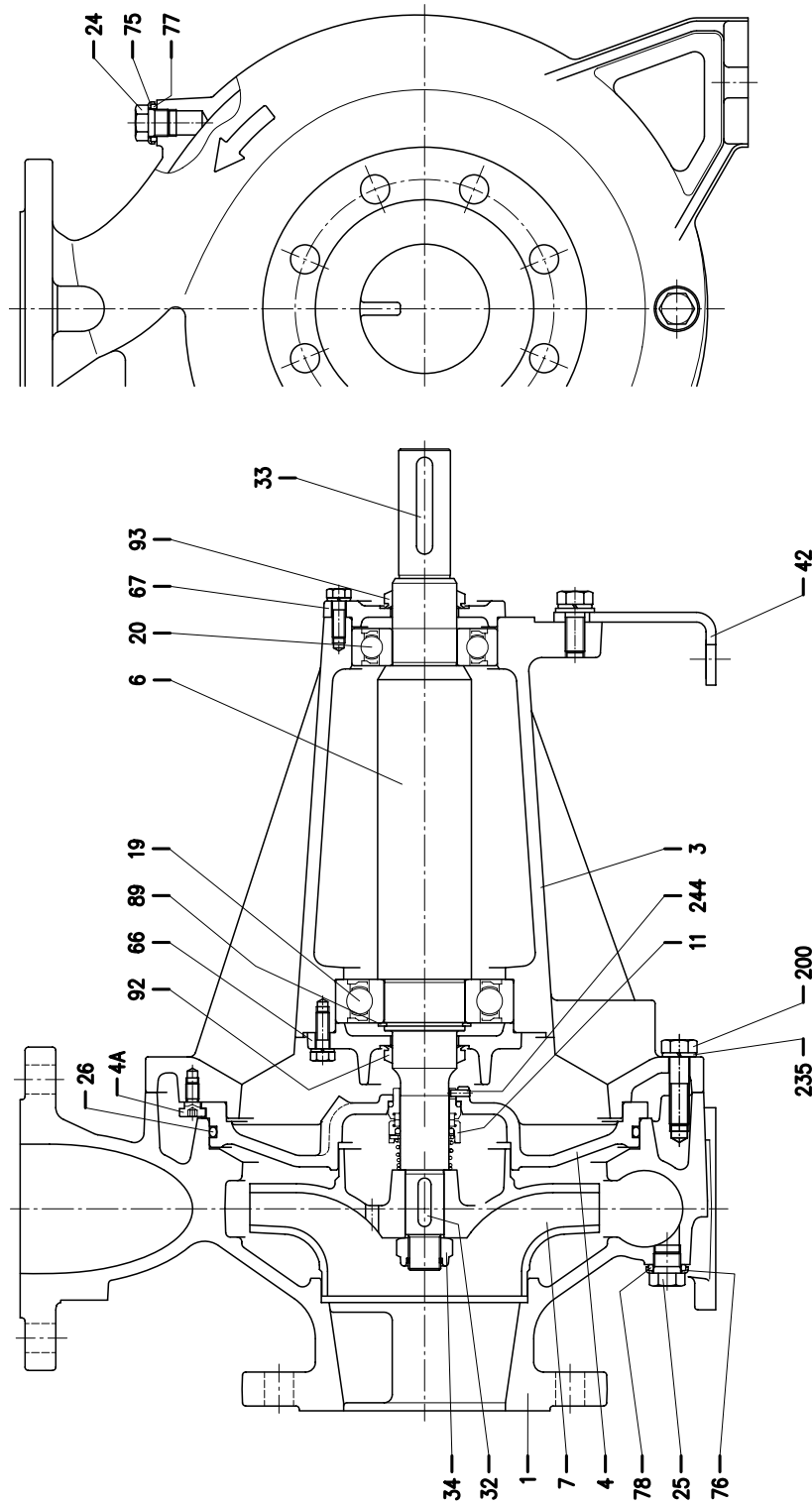

SECTIONAL VIEW DRAWING 3LP 65-250, 80-160/200/250

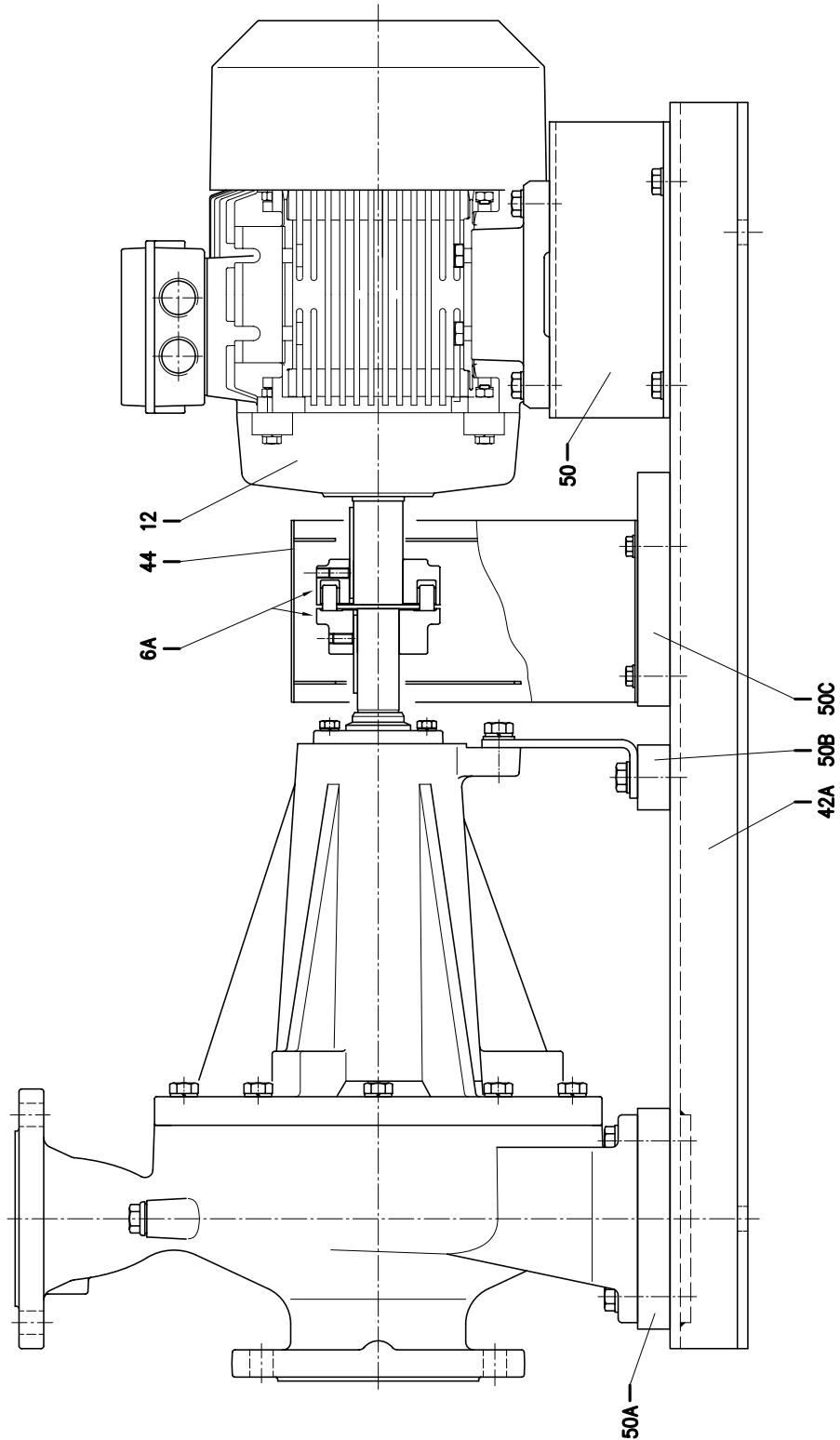

SECTIONAL VIEW TABLE 3LP 80-160

N°	PART NAME	MATERIAL	DIMENSIONS	STANDARD	Q.TY
1	Casing	CF8M-EN 1.4408 (AISI 316)			1
3	Support	Cast iron EN-GJL-200-EN 1561			1
4	Casing cover	EN 1.4404 (AISI 316L)			1
6	Shaft	EN 1.4404 (AISI 316L) - Wet extension			1
6 A	Flexible coupling	Cast iron EN-GJL-250-EN 1561	See table p. 334		1
7	Impeller	CF8M-EN 1.4408 (AISI 316)			1
11	Mechanical seal	SiC/SiC/FPM	[3]		1
12	Motor	-			1
19	Bearing	-	See table p. 325		1
20	Bearing	-	See table p. 325		1
24	Plug	EN 1.4404 (AISI 316L)	G3/8	EPE DRAWING	1
25	Plug	EN 1.4404 (AISI 316L)	G3/8	EPE DRAWING	1
26	"O" ring	FPM [2]	227.96x5.34	OR 6895	1
32	Key	EN 1.4401 (AISI 316)	8x7x30	UNI 6604	1
33	Key	C 40	8x7x40		1
34	Impeller nut	EN 1.4404 (AISI 316L)	M20x1.5	UNI 7474	1
42	Pump support	Galvanized steel		EPE DRAWING	1
42 A	Base	Galvanized steel		EPE DRAWING	1
44	Protection	Galvanized steel		EPE DRAWING	1
50	Foot	Aluminium		EPE DRAWING	2
50 A	Spacer for pump	/			/
50 B	Spacer for pump	/			/
50 C	spacer for protection	/			/
66	Impeller side bearing cover	Cast iron EN-GJL-200-EN 1561			1
67	Motor side bearing cover	Cast iron EN-GJL-200-EN 1561			1
75	Washer (plug)	EN 1.4404 (AISI 316L)			1
76	Washer (plug)				1
77	O-ring (plug)	FPM [2]			1
78	O-ring (plug)				1
89	Snap ring	Carbon tool steels TC 80	Ø 40	UNI 7435	1
92	"V" ring	-	VS-0030		1
93	"V" ring				1
200	Screw	Stainless steel A2 70 class ISO 3506/1	M 10x35	UNI 5739	10
200 A	Screw		M 10x30		2
235	Washer	EN 1.4301(AISI 304)	10.5	UNI 8842	12
244	Pin [1]	EN 1.4301(AISI 304)	4x15	UNI 6873	1

Counterflange kit on request, see table p. 335-336

[1] Not for H and E option.

[2] FPM for H, HW, HSW version

EPDM for E version, Q1AEGG, Q1Q1EGG, Q1U3EGG, U3CEGG.

[3] Special version: see page 326 and following

For drawing see p.319

SECTIONAL VIEW TABLE 3LP 65-250, 80-200/250

N°	PART NAME			MATERIAL	DIMENSIONS	STANDARD	Q.TY
1	Casing			CF8M-EN 1.4408 (AISI 316)			1
3	Support			Cast iron EN-GJL-200-EN 1561			1
4	Casing cover			EN 1.4401 (AISI 316)			1
4 A	Screw for casing cover			EN 1.4301 (AISI 304)			2
6	Shaft			EN 1.4462 (Duplex stainless steel) - Wet extension			1
6 A	Flexible coupling			Cast iron EN-GJL-250-EN 1561	See table p. 334		1
7	Impeller			CF8M-EN 1.4408 (AISI 316)			1
11	Mechanical seal			SiC/SiC/FPM	[5]		1
12	Motor			-			1
19	Bearing			-	See table p. 325		1
20	Bearing			-	See table p. 325		1
24	Plug			EN 1.4404 (AISI 316L)	G3/8		1
25	Plug			EN 1.4404 (AISI 316L)	G3/8		1
26	"O" ring			FPM [4]	253.36x5.34	OR 6995	1
32	Key	65-250	d=24 mm	EN 1.4401 (AISI 316)	8x7x30	UNI 6604	1
		80-200					1
		80-250					d=29 mm
33	Key			C 40	10x8x60	UNI 6604	1
34	impeller nut	65-250	d=24 mm	EN 1.4404 (AISI 316L)	M20x1.5	UNI 7474	1
		80-200					1
		80-250					d=29 mm
42	Pump support			Galvanized steel			1
42 A	Base			Galvanized steel			1
44	Protection			Galvanized steel			1
50	Foot (only for 65-250/22kW)			Aluminium			2
50 A	Spacer			Aluminium			[1]
50 B	Spacer			Aluminium			[2]
50 C	Spacer for protection			Aluminium			[3]
66	Impeller side bearing cover			Cast iron EN-GJL-200-EN 1561			1
67	Motor side bearing cover			Cast iron EN-GJL-200-EN 1561			1
75	Washer (plug)			EN 1.4404 (AISI 316L)			1
76	Washer (plug)						1
77	O-ring (plug)						1
78	O-ring (plug)			FPM [4]			1
89	Snap ring			Carbon tool steels TC 80	Ø 50	UNI 7435	1
92	"V" ring			-	VS-0040		1
93	"V" ring						
200	Screw			Stainless steel A2 70 class ISO 3506/1	M 12x45	UNI 5739	10
235	Washer			EN 1.4301 (AISI 304)	13	UNI 8842	10
244	Pin [3]			EN 1.4301 (AISI 304)	4x12	UNI 6873	1

Counterflange kit on request, see table p. 335-336

[1] Quantity =0 for 65-250, 80-200/22 and 80-250/55
Quantity =2 for 80-200/30, 80-200/37 and 80-250/45

[2] Quantity =0 for 65-250, 80-200/22 and 80-250/55
Quantity =2 for 80-200/30, 80-200/37 and 80-250/45

[3] Not for H and E option.

[4] FPM for H, HW, HSW version

EPDM for E version and for Q1Q1EGG, Q1U3EGG, U3CEGG, Q1AEGG

EPDM for ES version only model 80-250

[5] Special version: see page 326 and following

For drawing see p.320-321

BEARINGS 3(.)M

Pump type		Ball bearing						
Single Phase 50 Hz	Three Phase 50 Hz	Pump side	(*) Pump side	Fan side	(*) Fan side			
3(.)M 32-125/1.1 M	3(.)M(Z) 32-125/1.1	6205-2RSH	6205-ZZ C3	6205-2RSH	6203-ZZ C3			
3(.)M 32-160/1.5 M	3(.)M(Z) 32-160/1.5				6205-ZZ C3			
3(.)M 32-160/2.2 M	3(.)M(Z) 32-160/2.2							
-	3(.)M(Z) 32-200/3	6206-2RS1	6206-ZZ C3	6206-2RS1	6205-ZZ C3			
	3(.)M(Z) 32-200/4							
	3(.)M(Z) 32-200/5.5	6306-2RS1	6306-ZZ C3	6206-2RS1	6206-ZZ C3			
	3(.)M(Z) 32-200/7.5							
3(.)M 40-125/1.5 M	3(.)M(Z) 40-125/1.5	6205-2RSH	6205-ZZ C3	6205-2RSH	6203-ZZ C3			
3(.)M 40-125/2.2 M	3(.)M(Z) 40-125/2.2							
-	3(.)M(Z) 40-160/3				6206-2RS1	6206-ZZ C3	6206-2RS1	6205-ZZ C3
	3(.)M(Z) 40-160/4							
	3(.)M(Z) 40-200/5.5	6306 2RS1	6306 ZZ C3	6206-2RS1	6206-ZZ C3			
	3(.)M(Z) 40-200/7.5							
	3(.)M(Z) 40-200/11							
3(.)M 50-125/2.2 M	3(.)M(Z) 50-125/2.2	6205-2RSH	6205-ZZ C3	6205-2RSH	6203-ZZ C3			
-	3(.)M(Z) 50-125/3				6206-2RS1	6206-ZZ C3	6206-2RS1	6205-ZZ C3
	3(.)M(Z) 50-125/4							
	3(.)M(Z) 50-160/5.5	6306-2RS1	6306-ZZ C3	6206-2RS1	6206-ZZ C3			
	3(.)M(Z) 50-160/7.5							
	3(.)M(Z) 50-200/9.2	6308-2RS1	6308-ZZ C3	6208-2RS1	6208-ZZ C3			
	3(.)M(Z) 50-200/11							
	3(.)M(Z) 50-200/15	6309-2RS1	6309-ZZ C3	6309-2RS1	6309-ZZ C3			
	3(.)M(Z) 65-125/4							
	3(.)M(Z) 65-125/5.5	6206-2RS1	6206-ZZ C3	6205-2RSH	6205-ZZ C3			
	3(.)M(Z) 65-125/7.5							
	3(.)M(Z) 65-160/7.5							
	3(.)M(Z) 65-160/9.2	6308-2RS1	6308-ZZ C3	6208-2RS1	6208-ZZ C3			
	3(.)M(Z) 65-160/11							
	3(.)M(Z) 65-160/15	6309-2RS1	6309-ZZ C3	6309-2RS1	6309-ZZ C3			
	3(.)M(Z) 65-200/15							
	3(.)M(Z) 65-200/18.5							
	3(.)M(Z) 65-200/22							
	3LM 80-160/11	6308-2RS1	6308-ZZ C3	6208-2RS1	6208-ZZ C3			
	3LM 80-160/15R	6309-2RS1	6309-ZZ C3	6309-2RS1	6309-ZZ C3			
	3LM 80-160/15							
3LM 80-160/18.5								

(*) Only for IE3 Motors

BEARINGS 3(.)S-3(.)P

Pump type	Ball bearing	
	Pump side	Fan side
3(.)S(Z) 32-125/1.1	6204-2Z C3	6204-2Z C3
3(.)S(Z) 32-160/1.5	6205-2Z C3	6205-2Z C3
3(.)S(Z) 32-160/2.2		
3(.)S(Z) 32-200/3	6206-2Z C3	6206-2Z C3
3(.)S(Z) 32-200/4	6306-2Z C3	6306-2Z C3
3(.)S(Z) 32-200/5.5	6208-2Z C3	6208-2Z C3
3(.)S(Z) 32-200/7.5		
3(.)S(Z) 40-125/1.5	6205-2Z C3	6205-2Z C3
3(.)S(Z) 40-125/2.2		
3(.)S(Z) 40-160/3	6206-2Z C3	6206-2Z C3
3(.)S(Z) 40-160/4	6306-2Z C3	6306-2Z C3
3(.)S(Z) 40-200/5.5	6208-2Z C3	6208-2Z C3
3(.)S(Z) 40-200/7.5		
3(.)S(Z) 40-200/11	6309-2Z C3	6309-2Z C3
3(.)S(Z) 50-125/2.2	6205-2Z C3	6205-2Z C3
3(.)S(Z) 50-125/3	6206-2Z C3	6206-2Z C3
3(.)S(Z) 50-125/4	6306-2Z C3	6306-2Z C3
3(.)S(Z) 50-160/5.5	6208-2Z C3	6208-2Z C3
3(.)S(Z) 50-160/7.5		
3(.)S(Z) 50-200/9.2		
3(.)S(Z) 50-200/11	6309-2Z C3	6309-2Z C3
3(.)S(Z) 50-200/15		
3(.)S(Z) 65-125/4	6306-2Z C3	6306-2Z C3
3(.)S(Z) 65-125/5.5	6208-2Z C3	6208-2Z C3
3(.)S(Z) 65-125/7.5		
3(.)S(Z) 65-160/7.5		
3(.)S(Z) 65-160/9.2		
3(.)S(Z) 65-160/11	6309-2Z C3	6309-2Z C3
3(.)S(Z) 65-160/15		
3(.)S(Z) 65-200/15		
3(.)S(Z) 65-200/18.5		
3(.)S(Z) 65-200/22	6311 C3	6311 C3 1)
3LS 65-250/30	6312 C3	6312 C3 1)
3LS 65-250/37		
3LS 80-160/11	6309-2Z C3	6309-2Z C3
3LS 80-160/15R		
3LS 80-160/15		
3LS 80-160/18.5		
3LS 80-200/22	6311 C3	6311 C3 1)
3LS 80-200/30	6312 C3	6312 C3 1)
3LS 80-200/37		
3LS 80-250/37		
3LS 80-250/45	6313 C3	6313 C3 1)
3LS 80-250/55	6314 C3	6314 C3 1)

Pump type	Ball bearing			
	Pump		Motor	
	Pump side	Motor side	Pump side	Fan side
3(.)P 32-125/1.1	6306-2RS 1	6206-2RS 1	6204-2Z C3	6204-2Z C3
3(.)P 32-160/1.5			6205-2Z C3	6205-2Z C3
3(.)P 32-160/2.2				
3(.)P 32-200/3	6308-2RS 1	6306-2RS 1	6206-2Z C3	6206-2Z C3
3(.)P 32-200/4			6306-2Z C3	6306-2Z C3
3(.)P 32-200/5.5			6208-2Z C3	6208-2Z C3
3(.)P 32-200/7.5				
3(.)P 40-125/1.5	6306-2RS 1	6206-2RS 1	6205-2Z C3	6205-2Z C3
3(.)P 40-125/2.2				
3(.)P 40-160/3			6206-2Z C3	6206-2Z C3
3(.)P 40-160/4			6306-2Z C3	6306-2Z C3
3(.)P 40-200/5.5	6308-2RS 1	6306-2RS 1	6208-2Z C3	6208-2Z C3
3(.)P 40-200/7.5				
3(.)P 40-200/11			6309-2Z C3	6309-2Z C3
3(.)P 50-125/2.2	6306-2RS 1	6206-2RS 1	6205-2Z C3	6205-2Z C3
3(.)P 50-125/3			6206-2Z C3	6206-2Z C3
3(.)P 50-125/4			6306-2Z C3	6306-2Z C3
3(.)P 50-160/5.5	6308-2RS 1	6306-2RS 1	6208-2Z C3	6208-2Z C3
3(.)P 50-160/7.5				
3(.)P 50-200/9.2				
3(.)P 50-200/11			6309-2Z C3	6309-2Z C3
3(.)P 50-200/15				
3(.)P 65-125/4	6306-2RS 1	6206-2RS 1	6306-2Z C3	6306-2Z C3
3(.)P 65-125/5.5				
3(.)P 65-125/7.5			6208-2Z C3	6208-2Z C3
3(.)P 65-160/7.5	6308-2RS 1	6306-2RS 1		
3(.)P 65-160/9.2				
3(.)P 65-160/11			6309-2Z C3	6309-2Z C3
3(.)P 65-160/15				
3(.)P 65-200/15				
3(.)P 65-200/18.5				
3(.)P 65-200/22	6310-2RS 1	6308-2RS 1	6311 C3	6311 C3 1)
3LP 65-250/30			6312 C3	6312 C3 1)
3LP 65-250/37				
3LP 80-160/11	6308-2RS 1 C3	6306-2RS 1 C3	6309-2Z C3	6309-2Z C3
3LP 80-160/15R				
3LP 80-160/15				
3LP 80-160/18.5				
3LP 80-200/22	6310-2RS 1 C3	6308-2RS 1 C3	6311 C3	6311 C3 1)
3LP 80-200/30				
3LP 80-200/37				
3LP 80-250/37			6312 C3	6312 C3 1)
3LP 80-250/45				
3LP 80-250/55			6313 C3	6313 C3 1)
			6314 C3	6314 C3 1)

1) Motor available with lubricator for regular re-greasing of bearing.

MECHANICAL SEAL (standard, H, E and Special version)

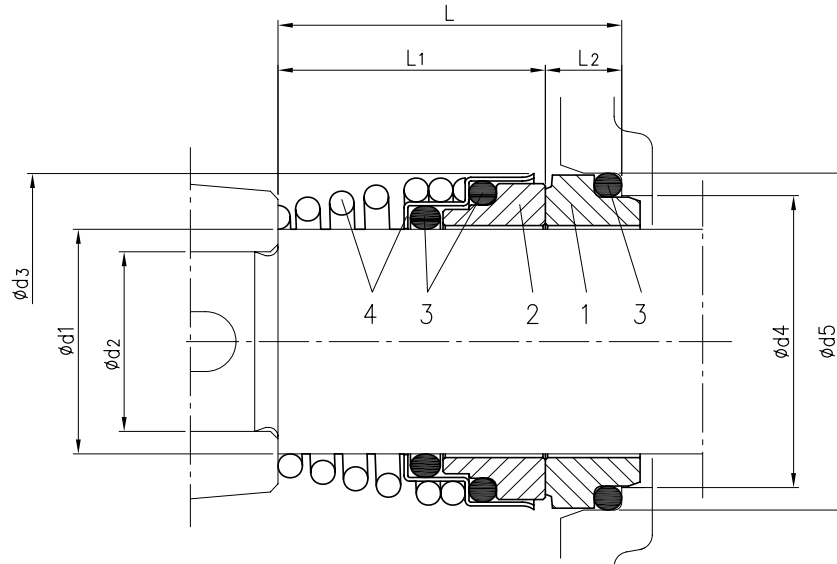

Version	Pump type	Dimensions								Material			
		d1	d2	d3	d4	d5	L	L1	L2	1 Stationary seal ring	2 Rotary seal ring	3 Rubber	4 Frame + Spring
Standard	32-125/160/200 40-125/160/200 50-125/160/200 65-125 65-160/7.5-9.2-11	22	19	38	31	37	37.5	27.5	10	Carbon	Ceramic	NBR	EN 1.4401 (AISI 316)
	65-160/15 65-200	30	24	46	39	45	42.5	32.5	10				
H	32-125/160/200 40-125/160/200 50-125/160/200 65-125 65-160/7.5-9.2-11	22	19	38	31	37	37.5	27.5	10	Carbon	Ceramic	FPM	EN 1.4401 (AISI 316)
	65-160/15 65-200/250 80-160/200	30	24	46	39	45	42.5	32.5	10				
	80-250	35	29	50	44	50	42.5	32.5	10				
E	32-125/160/200 40-125/160/200 50-125/160/200 65-125 65-160/7.5-9.2-11	22	19	38	31	37	37.5	27.5	10	Carbon	Ceramic	EPDM	EN 1.4401 (AISI 316)
	65-160/15 65-200/250 80-160/200	30	24	46	39	45	42.5	32.5	10				
Q1AEGG*	65-160/15 65-200/250 80-160/200	30	24	46	39	45	42.5	32.5	10	Silicon Carbide	Metallised Carbon	EPDM	EN 1.4401 (AISI 316)

* The drawing is only indicative

MECHANICAL SEAL (L version ø22)

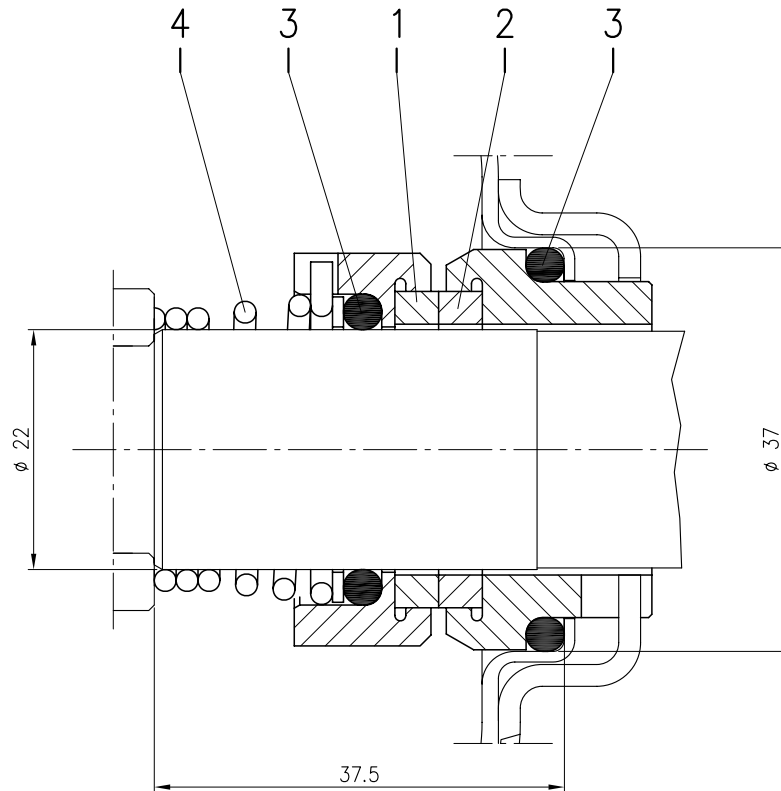

Version	Pump type	Material			
		1 Stationary seal ring	2 Rotary seal ring	3 Rubber	4 Frame + spring
L ø22	32-125/160/200 40-125/160/200 50-125/160/200 65-125 65-160/7.5-9.2-11	SiC	SiC	FPM	EN 1.4571 (AISI 316Ti)

MECHANICAL SEAL (L version ø30-35)

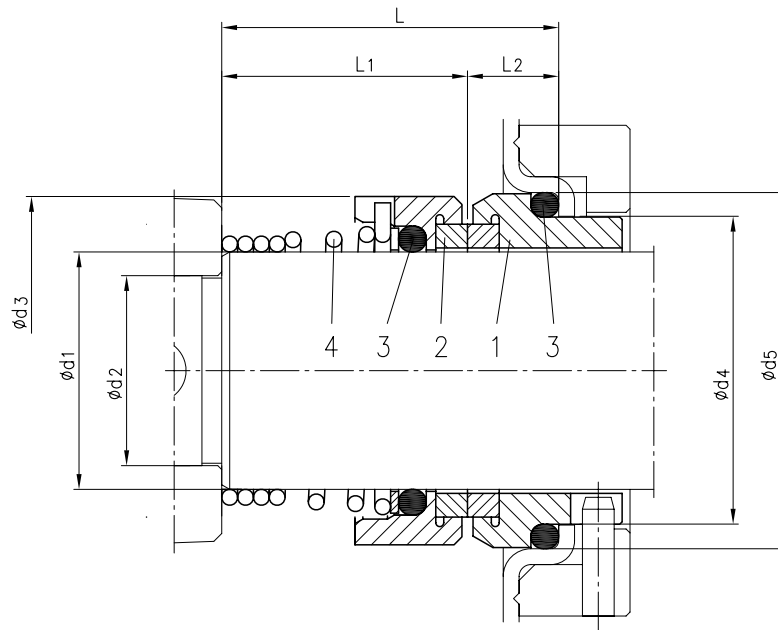

Version	Pump type	Dimensions								Material			
		d1	d2	d3	d4	d5	L	L1	L2	1 Stationary seal ring	2 Rotary seal ring	3 Rubber	4 Frame + spring
L ø30	65-160/15 65-200/250 80-160/200	30	24	44	39	45	42.5	31	11.5	SiC	SiC	FPM	EN 1.4571 (AISI 316Ti)
L ø35	80-250	35	29	49	44	50	42.5	31	11.5				

MECHANICAL SEAL (HS version and Special version ø22)

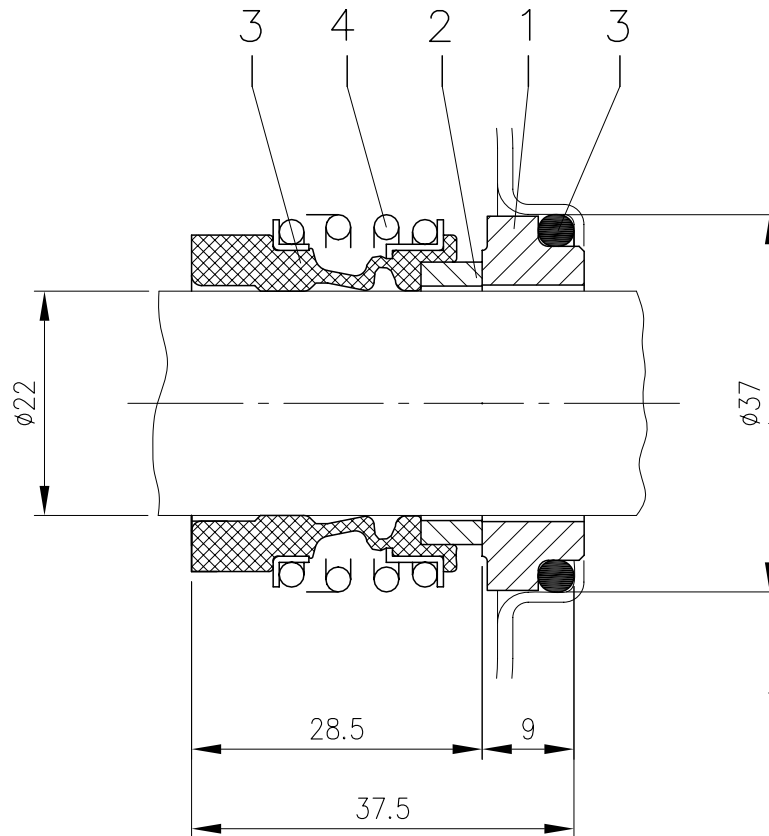

Version	Pump type	Material			
		1 Stationary seal ring	2 Rotary seal ring	3 Rubber	4 Frame + spring
HS ø22	32-125/160/200 40-125/160/200 50-125/160/200 65-125 65-160/7.5-9.2-11	SiC	SiC	FPM	EN 1.4571 (AISI 316Ti)
Q1AEGG*	32-125/160/200 40-125/160/200 50-125/160/200 65-125 65-160/7.5-9.2-11	SiC	Metallised Carbon	EPDM	EN 1.4401 (AISI 316)

* The drawing is only indicative

MECHANICAL SEAL (HS version ø30)

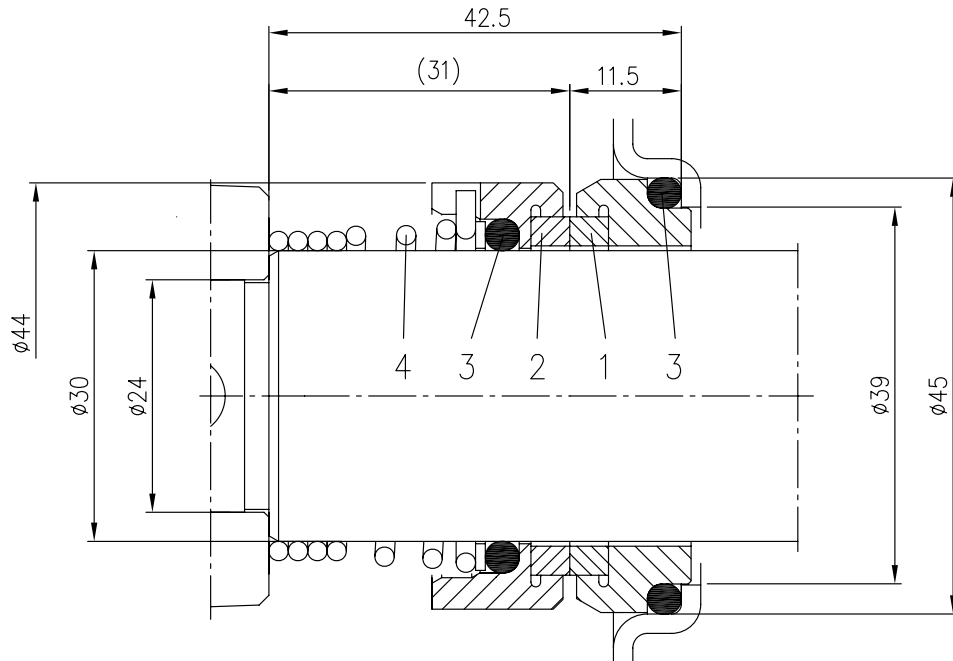

Version	Pump type	Material			
		1 Stationary seal ring	2 Rotary seal ring	3 Rubber	4 Frame + spring
HS ø 30	65-160/15 65-200	SiC	SiC	FPM	EN 1.4571 (AISI 316 Ti)

MECHANICAL SEAL (HW, HSW and Special version)

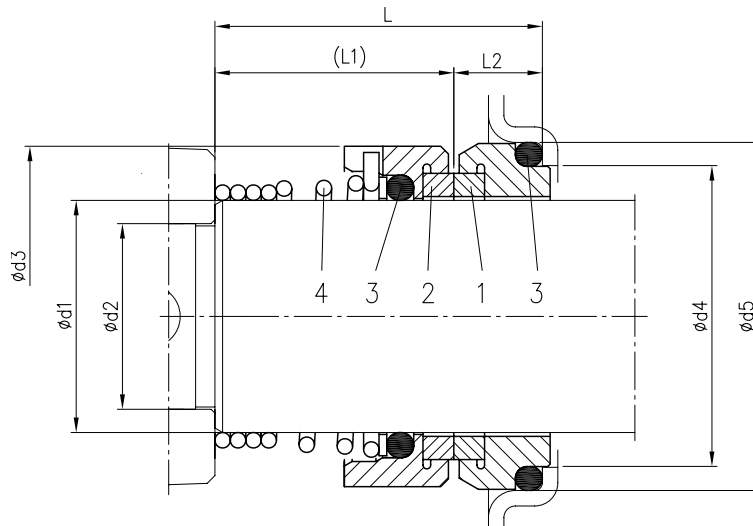

Version	Pump type	Dimensions								Material			
		d1	d2	d3	d4	d5	L	L1	L2	1 Stationary seal ring	2 Rotary seal ring	3 Rubber	4 Frame + spring
HW	32-125/160/200 40-125/160/200 50-125/160/200 65-125 65-160/7.5-9.2-11	22	19	38	31	37	37.5	27.5	10	Tungsten Carbide	Tungsten Carbide	FPM	EN 1.4401 (AISI 316)
	65-160/15 65-200/250 80-160/200	30	24	46	39	45	42.5	32.5	10				
	80-250	35	29	50	44	50	42.5	32.5	10				
	32-125/160/200 40-125/160/200 50-125/160/200 65-125 65-160/7.5-9.2-11	22	19	38	31	37	37.5	27.5	10				
	65-160/15 65-200/250 80-160/200 80-250	30	24	46	39	45	42.5	32.5	10				
HSW	32-125/160/200 40-125/160/200 50-125/160/200 65-125 65-160/7.5-9.2-11	22	19	38	31	37	37.5	27.5	10	Tungsten Carbide	SiC	FPM	EN 1.4401 (AISI 316)
	65-160/15 65-200/250 80-160/200	30	24	46	39	45	42.5	32.5	10				
	80-250	35	29	50	44	50	42.5	32.5	10				
	32-125/160/200 40-125/160/200 50-125/160/200 65-125 65-160/7.5-9.2-11	22	19	38	31	37	37.5	27.5	10				
	65-160/15 65-200/250 80-160/200	30	24	46	39	45	42.5	32.5	10				
U3U3EGG*	32-125/160/200 40-125/160/200 50-125/160/200 65-125 65-160/7.5-9.2-11	22	19	38	31	37	37.5	27.5	10	Tungsten Carbide	Tungsten Carbide	EPDM	EN 1.4401 (AISI 316)
	65-160/15 65-200/250 80-160/200	30	24	46	39	45	42.5	32.5	10				
	32-125/160/200 40-125/160/200 50-125/160/200 65-125 65-160/7.5-9.2-11	22	19	38	31	37	37.5	27.5	10				
	65-160/15 65-200/250 80-160/200	30	24	46	39	45	42.5	32.5	10				
	32-125/160/200 40-125/160/200 50-125/160/200 65-125 65-160/7.5-9.2-11	22	19	38	31	37	37.5	27.5	10				
Q1Q1EGG*	32-125/160/200 40-125/160/200 50-125/160/200 65-125 65-160/7.5-9.2-11	22	19	38	31	37	37.5	27.5	10	Silicon Carbide	Silicon Carbide	EPDM	EN 1.4401 (AISI 316)
	65-160/15 65-200/250 80-160/200	30	24	46	39	45	42.5	32.5	10				
	32-125/160/200 40-125/160/200 50-125/160/200 65-125 65-160/7.5-9.2-11	22	19	38	31	37	37.5	27.5	10				
	65-160/15 65-200/250 80-160/200	30	24	46	39	45	42.5	32.5	10				
	32-125/160/200 40-125/160/200 50-125/160/200 65-125 65-160/7.5-9.2-11	22	19	38	31	37	37.5	27.5	10				
Q1U3EGG*	32-125/160/200 40-125/160/200 50-125/160/200 65-125 65-160/7.5-9.2-11	22	19	38	31	37	37.5	27.5	10	Silicon Carbide	Tungsten Carbide	EPDM	EN 1.4401 (AISI 316)
	65-160/15 65-200/250 80-160/200	30	24	46	39	45	42.5	32.5	10				
	32-125/160/200 40-125/160/200 50-125/160/200 65-125 65-160/7.5-9.2-11	22	19	38	31	37	37.5	27.5	10				
	65-160/15 65-200/250 80-160/200	30	24	46	39	45	42.5	32.5	10				
	32-125/160/200 40-125/160/200 50-125/160/200 65-125 65-160/7.5-9.2-11	22	19	38	31	37	37.5	27.5	10				
U3CEGG*	32-125/160/200 40-125/160/200 50-125/160/200 65-125 65-160/7.5-9.2-11	22	19	38	31	37	37.5	27.5	10	Tungsten Carbide	Silicon Carbide	EPDM	EN 1.4401 (AISI 316)
	65-160/15 65-200/250 80-160/200	30	24	46	39	45	42.5	32.5	10				
	32-125/160/200 40-125/160/200 50-125/160/200 65-125 65-160/7.5-9.2-11	22	19	38	31	37	37.5	27.5	10				
	65-160/15 65-200/250 80-160/200	30	24	46	39	45	42.5	32.5	10				
	32-125/160/200 40-125/160/200 50-125/160/200 65-125 65-160/7.5-9.2-11	22	19	38	31	37	37.5	27.5	10				

* The drawing is only indicative

MECHANICAL SEAL (ES version)

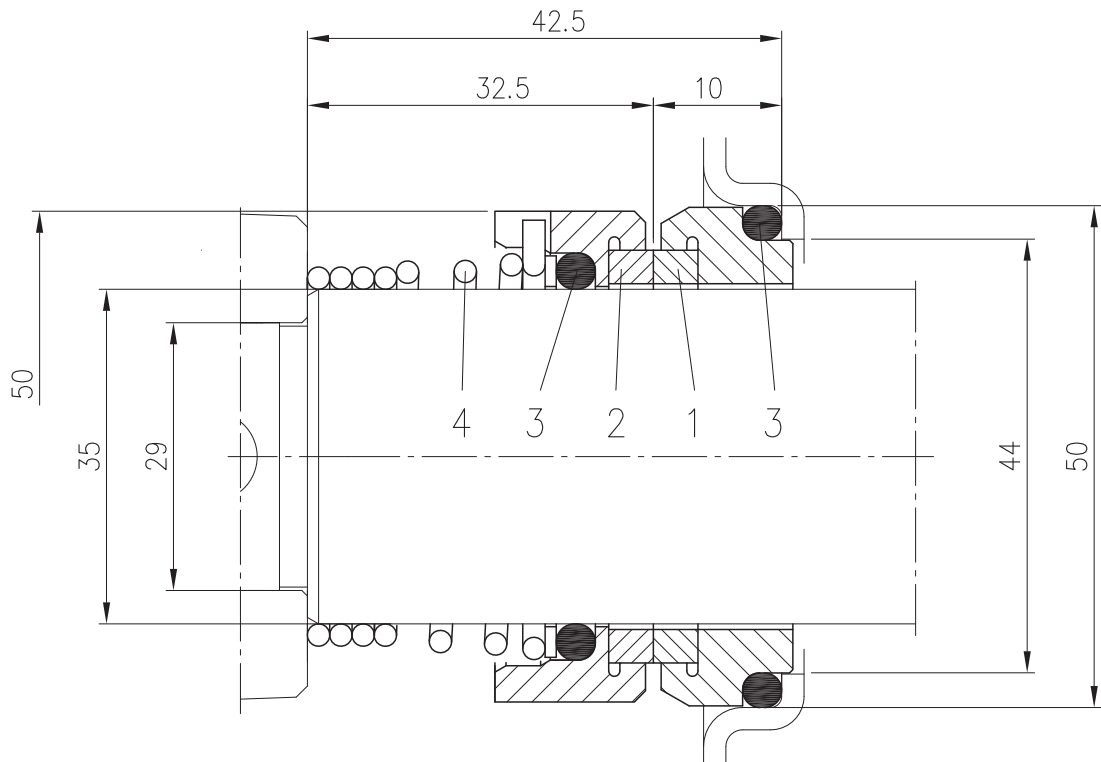

Pump type	Material			
	1 Stationary seal ring	2 Rotary seal ring	3 Rubber	4 Frame + Spring
80-250	Carbon	SiC	EPDM	EN 1.4401 (AISI 316)

COUPLING

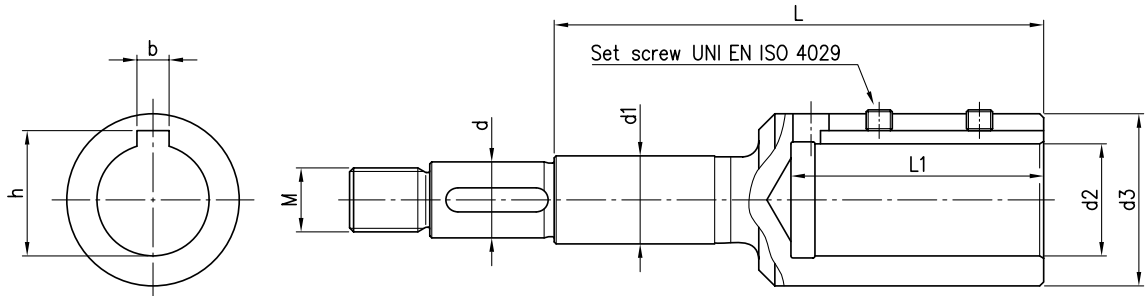

Pump type	Power		Motor Size	Dimensions mm										Set screw
	[kW]	[HP]		d	d1	d2	d3	M	L	L1	b	h		
32-125/1.1	1.1	1.5	80	19	22	19	33	M16x1.5	98	43	6	21.8	M6x6	
32-160/1.5	1.5	2	90	19	22	24	39	M16x1.5	110	53	8	27.3	M8x8	
32-160/2.2	2.2	3	90	19	22	24	39	M16x1.5	110	53	8	27.3	M8x8	
32-200/3.0	3	4	100	19	22	28	43	M16x1.5	122	63	8	31.3	M8x8	
32-200/4.0	4	5.5	112	19	22	28	43	M16x1.5	122	63	8	31.3	M8x8	
32-200/5.5	5.5	7.5	132	19	22	38	58	M16x1.5	145	84	10	41.3	M8x8	
32-200/7.5	7.5	10	132	19	22	38	58	M16x1.5	145	84	10	41.3	M8x8	
40-125/1.5	1.5	2	90	19	22	24	39	M16x1.5	110	53	8	27.3	M8x8	
40-125/2.2	2.2	3	90	19	22	24	39	M16x1.5	110	53	8	27.3	M8x8	
40-160/3.0	3	4	100	19	22	28	43	M16x1.5	122	63	8	31.3	M8x8	
40-160/4.0	4	5.5	112	19	22	28	43	M16x1.5	122	63	8	31.3	M8x8	
40-200/5.5	5.5	7.5	132	19	22	38	58	M16x1.5	145	84	10	41.3	M8x8	
40-200/7.5	7.5	10	132	19	22	38	58	M16x1.5	145	84	10	41.3	M8x8	
40-200/11	11	15	160	19	22	42	63	M16x1.5	178	114	12	45.3	M8x8	
50-125/2.2	2.2	3	90	19	22	24	39	M16x1.5	110	53	8	27.3	M8x8	
50-125/3.0	3	4	100	19	22	28	43	M16x1.5	122	63	8	31.3	M8x8	
50-125/4.0	4	5.5	112	19	22	28	43	M16x1.5	122	63	8	31.3	M8x8	
50-160/5.5	5.5	7.5	132	19	22	38	58	M16x1.5	145	84	10	41.3	M8x8	
50-160/7.5	7.5	10	132	19	22	38	58	M16x1.5	145	84	10	41.3	M8x8	
50-200/9.2	9.2	12.5	132	19	22	38	58	M16x1.5	145	84	10	41.3	M8x8	
50-200/11	11	15	160	19	22	42	63	M16x1.5	178	114	12	45.3	M8x8	
50-200/15	15	20	160	22	22	42	63	M18x1.5	209	114	12	45.3	M8x8	
65-125/4.0	4	5.5	112	19	22	28	43	M16x1.5	122	63	8	31.3	M8x8	
65-125/5.5	5.5	7.5	132	19	22	38	58	M16x1.5	145	84	10	41.3	M8x8	
65-125/7.5	7.5	10	132	19	22	38	58	M16x1.5	145	84	10	41.3	M8x8	
65-160/7.5	7.5	10	132	19	22	38	58	M16x1.5	145	84	10	41.3	M8x8	
65-160/9.2	9.2	12.5	132	19	22	38	58	M16x1.5	145	84	10	41.3	M8x8	
65-160/11	11	15	160	19	22	42	63	M16x1.5	178	114	12	45.3	M8x8	
65-160/15	15	20	160	24	30	42	63	M20x1.5	184	114	12	45.3	M8x8	
65-200/15	15	20	160	24	30	42	63	M20x1.5	184	114	12	45.3	M8x8	
65-200/18.5	18.5	25	160	24	30	42	63	M20x1.5	184	114	12	45.3	M8x8	
65-200/22	22	30	180	24	30	48	72	M20x1.5	184	114	14	51.8	M10x10	
65-250/30	30	40	200	24	30	55	85	M20x1.5	184	114	16	59.3	M12x12	
65-250/37	37	50	200	24	30	55	85	M20x1.5	184	114	16	59.3	M12x12	
80-160/11	11	15	160	24	30	42	63	M20x1.5	184	114	12	45.3	M8x8	
80-160/15R	15	20	160	24	30	42	63	M20x1.5	184	114	12	45.3	M8x8	
80-160/15	15	20	160	24	30	42	63	M20x1.5	184	114	12	45.3	M8x8	
80-160/18.5	18.5	25	160	24	30	42	63	M20x1.5	184	114	12	45.3	M8x8	
80-200/22	22	30	180	24	30	48	72	M20x1.5	184	114	14	51.8	M10x10	
80-200/30	30	40	200	24	30	55	85	M20x1.5	184	114	16	59.3	M12x12	
80-200/37	37	50	200	24	30	55	85	M20x1.5	184	114	16	59.3	M12x12	
80-250/37	37	50	200	29	35	55	85	M24x2	206	114	16	59.3	M12x12	
80-250/45	45	60	225	29	35	55	85	M24x2	206	114	16	59.3	M12x12	
80-250/55	55	75	250	29	35	60	89	M24x2	218	144	18	64.4	M12x12	

FLEXIBLE COUPLING

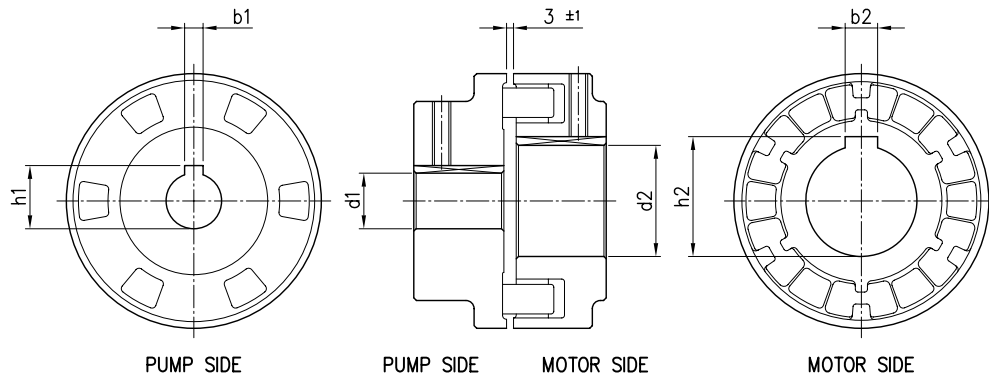

Pump type	Power		Motor Size	Dimensions mm					
	[KW]	[HP]		d1	b1	h1	d2	b2	h2
32-125/1.1	1.1	1.5	80	24	8	27.3	19	6	21.8
32-160/1.5	1.5	2	90	24	8	27.3	24	8	27.3
32-160/2.2	2.2	3	90	24	8	27.3	24	8	27.3
32-200/3.0	3	4	100	24	8	27.3	28	8	31.3
32-200/4.0	4	5.5	112	24	8	27.3	28	8	31.3
32-200/5.5	5.5	7.5	132	24	8	27.3	38	10	41.3
32-200/7.5	7.5	10	132	24	8	27.3	38	10	41.3
40-125/1.5	1.5	2	90	24	8	27.3	24	8	27.3
40-125/2.2	2.2	3	90	24	8	27.3	24	8	27.3
40-160/3.0	3	4	100	24	8	27.3	28	8	31.3
40-160/4.0	4	5.5	112	24	8	27.3	28	8	31.3
40-200/5.5	5.5	7.5	132	24	8	27.3	38	10	41.3
40-200/7.5	7.5	10	132	24	8	27.3	38	10	41.3
40-200/11	11	15	160	24	8	27.3	42	12	45.3
50-125/2.2	2.2	3	90	24	8	27.3	24	8	27.3
50-125/3.0	3	4	100	24	8	27.3	28	8	31.3
50-125/4.0	4	5.5	112	24	8	27.3	28	8	31.3
50-160/5.5	5.5	7.5	132	24	8	27.3	38	10	41.3
50-160/7.5	7.5	10	132	24	8	27.3	38	10	41.3
50-200/9.2	9.2	12.5	132	24	8	27.3	38	10	41.3
50-200/11	11	15	160	24	8	27.3	42	12	45.3
50-200/15	15	20	160	24	8	27.3	42	12	45.3
65-125/4.0	4	5.5	112	24	8	27.3	28	8	31.3
65-125/5.5	5.5	7.5	132	24	8	27.3	38	10	41.3
65-125/7.5	7.5	10	132	24	8	27.3	38	10	41.3
65-160/7.5	7.5	10	132	24	8	27.3	38	10	41.3
65-160/9.2	9.2	12.5	132	24	8	27.3	38	10	41.3
65-160/11	11	15	160	24	8	27.3	42	12	45.3
65-160/15	15	20	160	24	8	27.3	42	12	45.3
65-200/15	15	20	160	24	8	27.3	42	12	45.3
65-200/18.5	18.5	25	160	24	8	27.3	42	12	45.3
65-200/22	22	30	180	24	8	27.3	48	14	51.8
65-250/30	30	40	200	32	10	35.3	55	16	59.3
65-250/37	37	50	200	32	10	35.3	55	16	59.3
80-160/11	11	15	160	24	8	27.3	42	12	45.3
80-160/15R	15	20	160	24	8	27.3	42	12	45.3
80-160/15	15	20	160	24	8	27.3	42	12	45.3
80-160/18.5	18.5	25	160	24	8	27.3	42	12	45.3
80-200/22	22	30	180	32	10	35.3	48	14	51.8
80-200/30	30	40	200	32	10	35.3	55	16	59.3
80-200/37	37	50	200	32	10	35.3	55	16	59.3
80-250/37	37	50	200	32	10	35.3	55	16	59.3
80-250/45	45	60	225	32	10	35.3	55	16	59.3
80-250/55	55	75	250	32	10	35.3	60	18	64.4

FITTINGS

COUNTERFLANGE ZINCKED STEEL

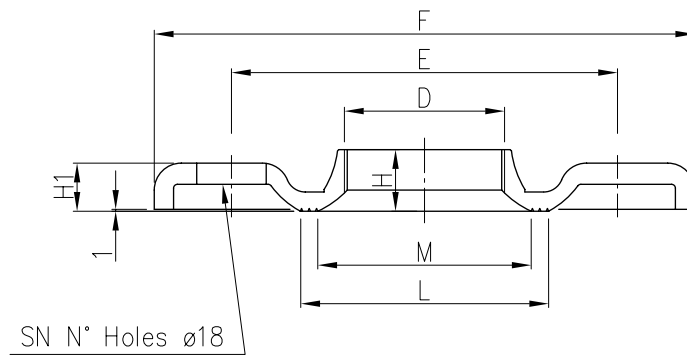

DN	D	Counterflange							Screw	
		E	F	H	H1	L	M	SN	DIMENSIONS	MATERIAL
32	G 1 1/4	100	140	15	11.5	67	50	4	M16x55	Gv. Steel 8.8 streight class ISO 898-1
40	G 1 1/2	110	150	17.5	11.5	72	58	4		
50	G2	125	165	19	15	89	70	4		
65	G 2 1/2	145	185	23	14	104	88	4		
80	G3	160	200	24	16	117.5	100	8	M16x60	
100	G4	180	220	29	16	144	125	8		

COUNTERFLANGE EN 1.4404 (AISI 316L)

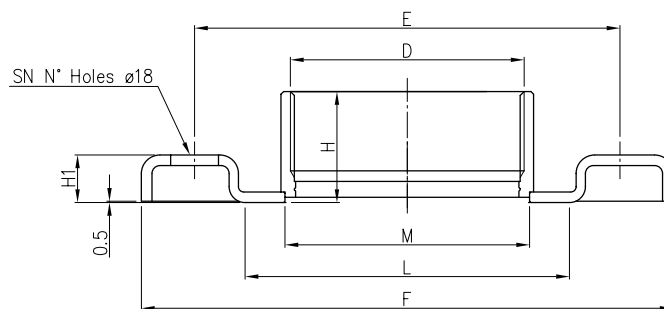

DN	D	Counterflange							Screw	
		E	F	H	H1	L	M	SN	DIMENSIONS	MATERIAL
32	G 1 1/4	100	140	29.5	14	66	44	4	M16x55	A2-70 class ISO 3506-1
40	G 1 1/2	110	150	29.5	14	71	50.5			
50	G 2	125	165	34	16	83	63			
65	G 2 1/2	145	185	40	16	103	80			
80	G3	160	200	42	18	122	92	8	M16x60	

COUNTERFLANGE EN 1.4404 (AISI 316L) DN100

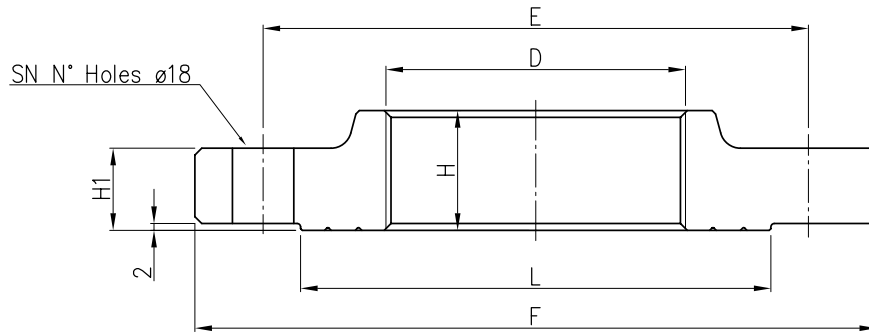

DN	D	Counterflange						Screw	
		E	F	H	H1	L	SN	DIMENSIONS	MATERIAL
100	G4	180	220	35	20	150	8	M16x70	A2-70 class ISO 3506-1

GASKET

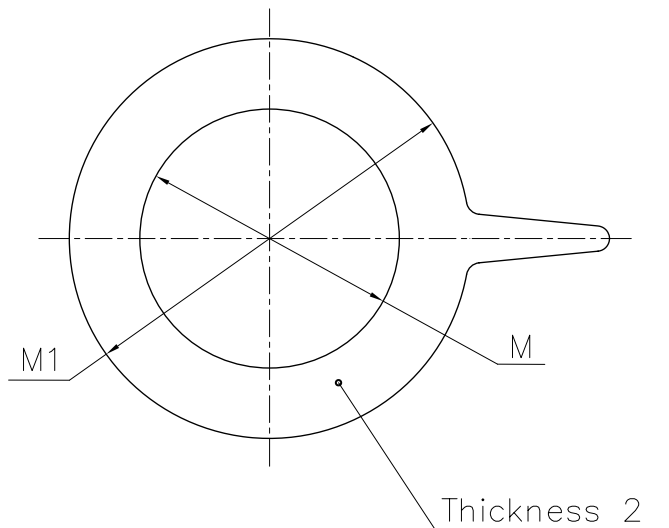

DN	M	M1
32	38	82
40	50	93
50	60	107
65	80	125
80	90	140
100	115	160

Material : EPDM for standard version
FPM for L version

PUMP 3(.)M 50-200, 65-160/15, 65-200

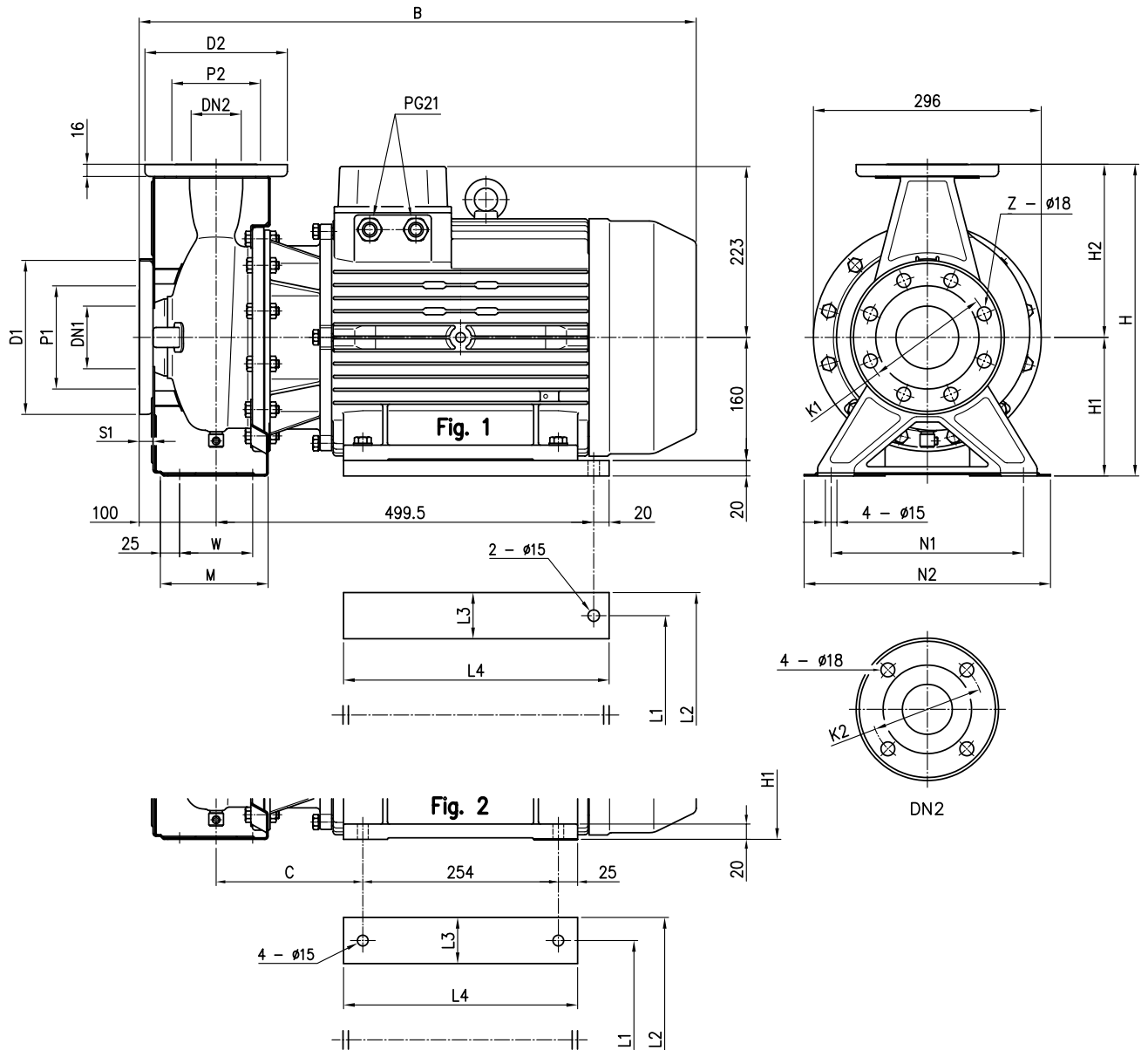

Model	Dimensions [mm]																								Weight [kgf]	
	∅ DN1	∅ P1	∅ K1	∅ D1	S1	Z [1]	Z [2]	∅ DN2	∅ P2	∅ K2	∅ D2	Fig.	H	H1	H2	W	M	N1	N2	B	C	L1	L2	L3		L4
50-200/15	65	115	145	185	16	4	-	50	95	125	165	2	360	160	200	70	115	212	265	723	190.5	254	318	65	304	105.1
65-160/15	80	134	160	200	18	8	4	65	115	145	185	2	360	160	200	95	140	212	280	732	199.5	254	318	65	304	107.1
65-200/15	80	134	160	200	18	8	4	65	115	145	185	1	405	180	225	95	140	250	320	732	-	254	314	60	345	110.1
65-200/18.5	80	134	160	200	18	8	4	65	115	145	185	1	405	180	225	95	140	250	320	732	-	254	314	60	345	125.3
65-200/22	80	134	160	200	18	8	4	65	115	145	185	1	405	180	225	95	140	250	320	732	-	254	314	60	345	136.1

[1] Standard [2] On request

PUMP 3LMZ 32, 40, 50-125/160/200/9.2/11, 65-125/160/7.5/9.2/11

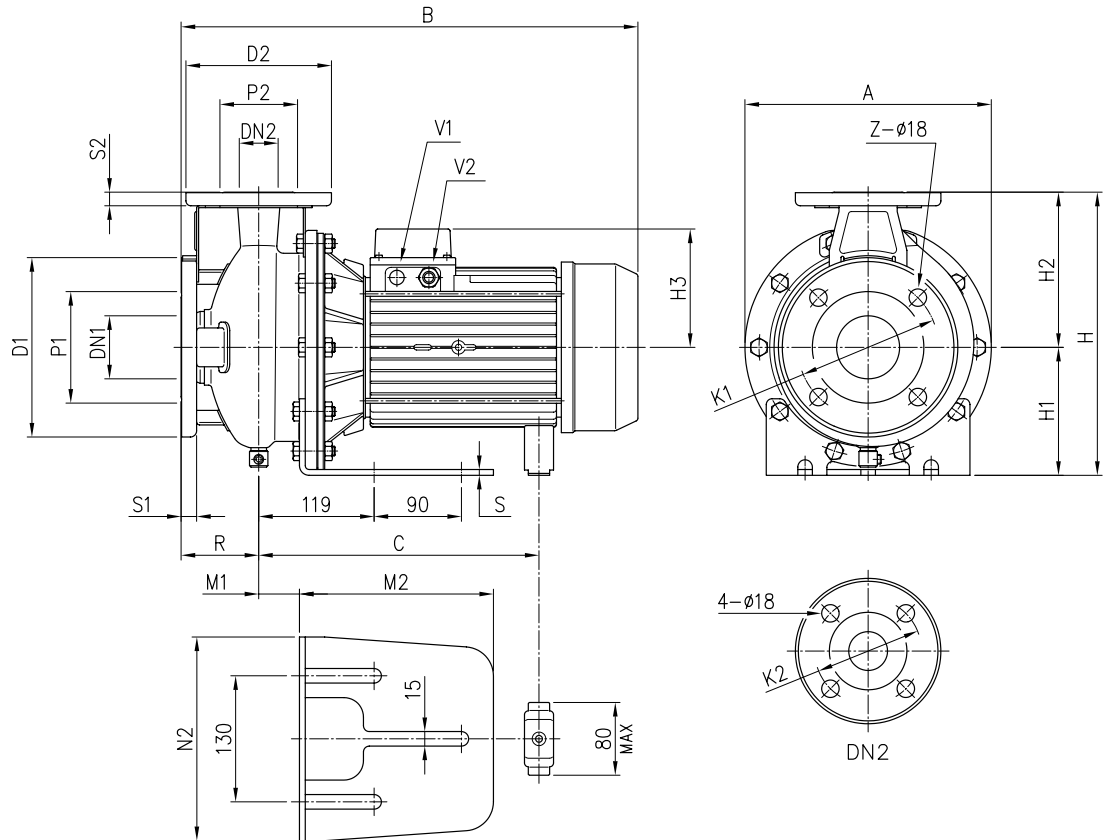

Model	Dimensions (mm)																				Weight Kgf					
	Ø DN1	Ø P1	Ø K1	Ø D1	S1	Z	Ø DN2	Ø P2	Ø K2	Ø D2	S2	H	H1	H2	H3	R	M1	M2	S	N2		A	B	C	V1	V2
32-125/1.1	50	95	125	165	16	4	32	75	100	140	14	252	112	140	119	80	32.5	212	6	190	213	431	-	-	M20x1.5	24.1
32-160/1.5	50	95	125	165	16	4	32	75	100	140	14	292	132	160	119	80	42	200	6	210	254	431	-	-	M20x1.5	27
32-160/2.2	50	95	125	165	16	4	32	75	100	140	14	292	132	160	119	80	42	200	6	210	254	431	-	-	M20x1.5	28
32-200/3.0	50	95	125	165	16	4	32	75	100	140	14	340	160	180	124	80	39	205	8	220	296	471	-	-	M20x1.5	35.1
32-200/4.0	50	95	125	165	16	4	32	75	100	140	14	340	160	180	141	80	39	205	8	220	296	494	-	-	M20x1.5	38.2
32-200/5.5	50	95	125	165	16	4	32	75	100	140	14	340	160	180	150	80	39	205	8	220	296	519	-	M20X1.5	52.2	
32-200/7.5	50	95	125	165	16	4	32	75	100	140	14	340	160	180	150	80	39	205	8	220	296	539	275	PG 13.5	PG 16	60.1
40-125/1.5	65	115	145	185	16	4	40	80	110	150	14	252	112	140	119	80	32.5	212	6	190	213	431	-	-	M20x1.5	24.6
40-125/2.2	65	115	145	185	16	4	40	80	110	150	14	252	112	140	119	80	32.5	212	6	190	213	431	-	-	M20x1.5	26.1
40-160/3.0	65	115	145	185	16	4	40	80	110	150	14	292	132	160	124	80	42	200	6	210	254	471	-	-	M20x1.5	26.6
40-160/4.0	65	115	145	185	16	4	40	80	110	150	14	292	132	160	141	80	42	200	6	210	254	491	-	-	M20x1.5	40.8
40-200/5.5	65	115	145	185	16	4	40	80	110	150	14	340	160	180	150	100	39	205	8	220	296	539	-	M20X1.5	M25x1.5	52.5
40-200/7.5	65	115	145	185	16	4	40	80	110	150	14	340	160	180	150	100	39	205	8	220	296	559	275	PG 13.5	PG 16	59.3
40-200/11	65	115	145	185	16	4	40	80	110	150	14	340	160	180	178	100	39	205	8	220	296	595	359	PG 13.5	PG 21	69.6
50-125/2.2	65	115	145	185	16	4	50	95	125	165	16	292	132	160	119	100	42	200	6	210	254	451	-	-	M20x1.5	32
50-125/3.0	65	115	145	185	16	4	50	95	125	165	16	292	132	160	124	100	42	200	6	210	254	491	-	-	M20x1.5	30.9
50-125/4.0	65	115	145	185	16	4	50	95	125	165	16	292	132	160	141	100	42	200	6	210	254	514	-	-	M20x1.5	40.9
50-160/5.5	65	115	145	185	16	4	50	95	125	165	16	340	160	180	150	100	39	205	8	220	296	539	-	M20X1.5	M25x1.5	46.5
50-160/7.5	65	115	145	185	16	4	50	95	125	165	16	340	160	180	150	100	39	205	8	220	296	559	275	PG 13.5	PG 16	58.6
50-200/9.2	65	115	145	185	16	4	50	95	125	165	16	360	160	200	178	100	39	205	8	220	296	595	359	PG 13.5	PG 21	63.9
50-200/11	65	115	145	185	16	4	50	95	125	165	16	360	160	200	178	100	39	205	8	220	296	595	359	PG 13.5	PG 21	69.6
65-125/4	80	134	160	200	18	8	65	115	145	185	16	340	160	180	141	100	42	200	6	210	254	514	-	-	M20x1.5	37.7
65-125/5.5	80	134	160	200	18	8	65	115	145	185	16	340	160	180	150	100	42	200	6	210	254	539	-	M20X1.5	M25x1.5	48.7
65-125/7.5	80	134	160	200	18	8	65	115	145	185	16	340	160	180	150	100	42	200	6	210	254	559	275	PG 13.5	PG 16	52.1
65-160/7.5	80	134	160	200	18	8	65	115	145	185	16	360	160	200	150	100	39	205	8	220	296	595	275	PG 13.5	PG 16	55.3
65-160/9.2	80	134	160	200	18	8	65	115	145	185	16	360	160	200	178	100	39	205	8	220	296	595	359	PG 13.5	PG 21	61
65-160/11	80	134	160	200	18	8	65	115	145	185	16	360	160	200	178	100	39	205	8	220	296	595	359	PG 13.5	PG 21	67.4

PUMP 3LMZ 50-200/15, 65-160/15, 65-200

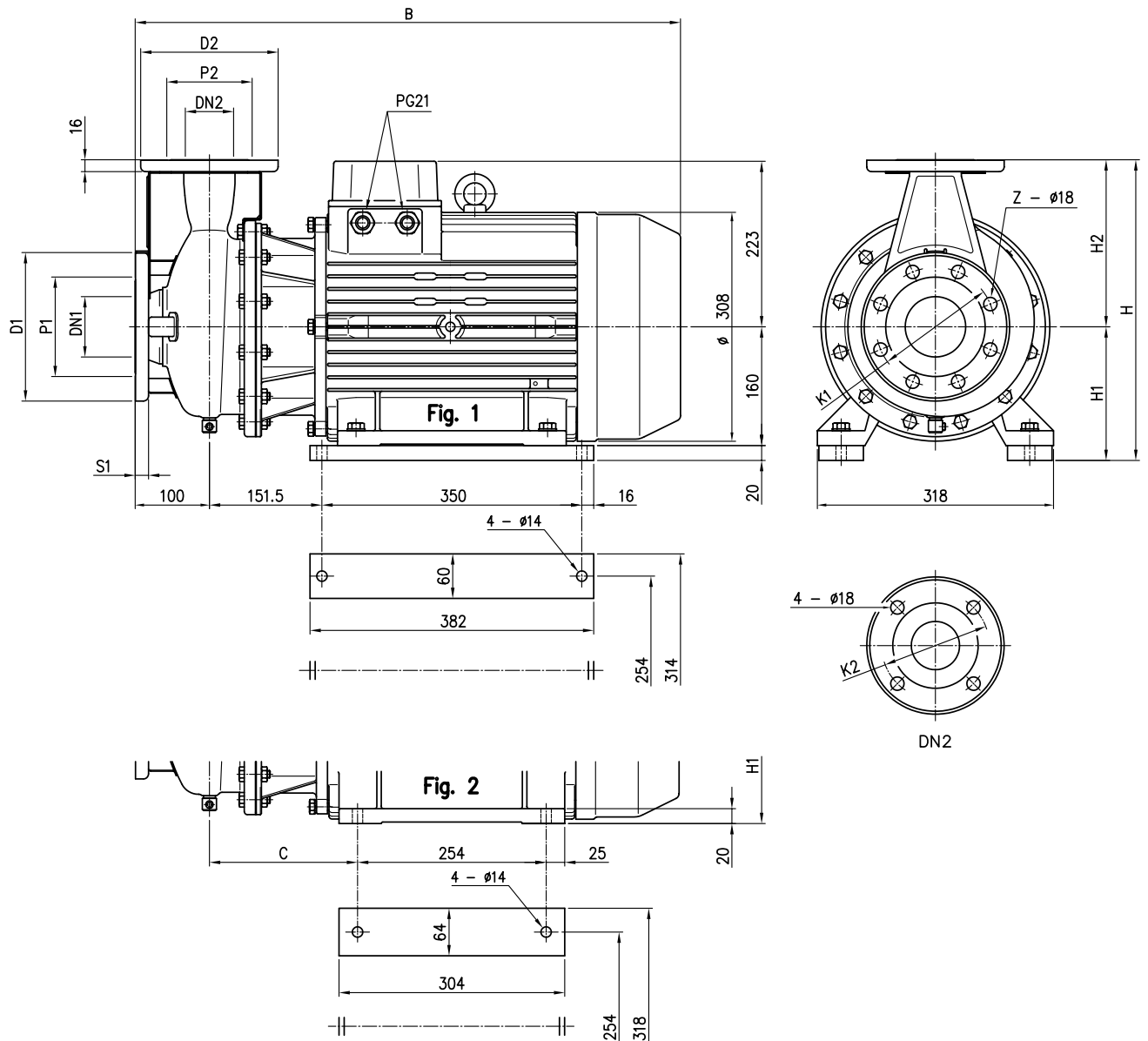

Model	Dimensions [mm]															Weight [kgf]	
	Ø DN1	Ø P1	Ø K1	Ø D1	S1	Z	Ø DN2	Ø P2	Ø K2	Ø D2	Fig.	H	H1	H2	B		C
50-200/15	65	115	145	185	16	4	50	95	125	165	2	360	160	200	723	190.5	105.1
65-160/15	80	134	160	200	18	8	65	115	145	185	2	360	160	200	732	199.5	107.1
65-200/15	80	134	160	200	18	8	65	115	145	185	1	405	180	225	732	-	110.1
65-200/18.5	80	134	160	200	18	8	65	115	145	185	1	405	180	225	732	-	125.3
65-200/22	80	134	160	200	18	8	65	115	145	185	1	405	180	225	732	-	136.1

PUMP 3LM 80-160/11

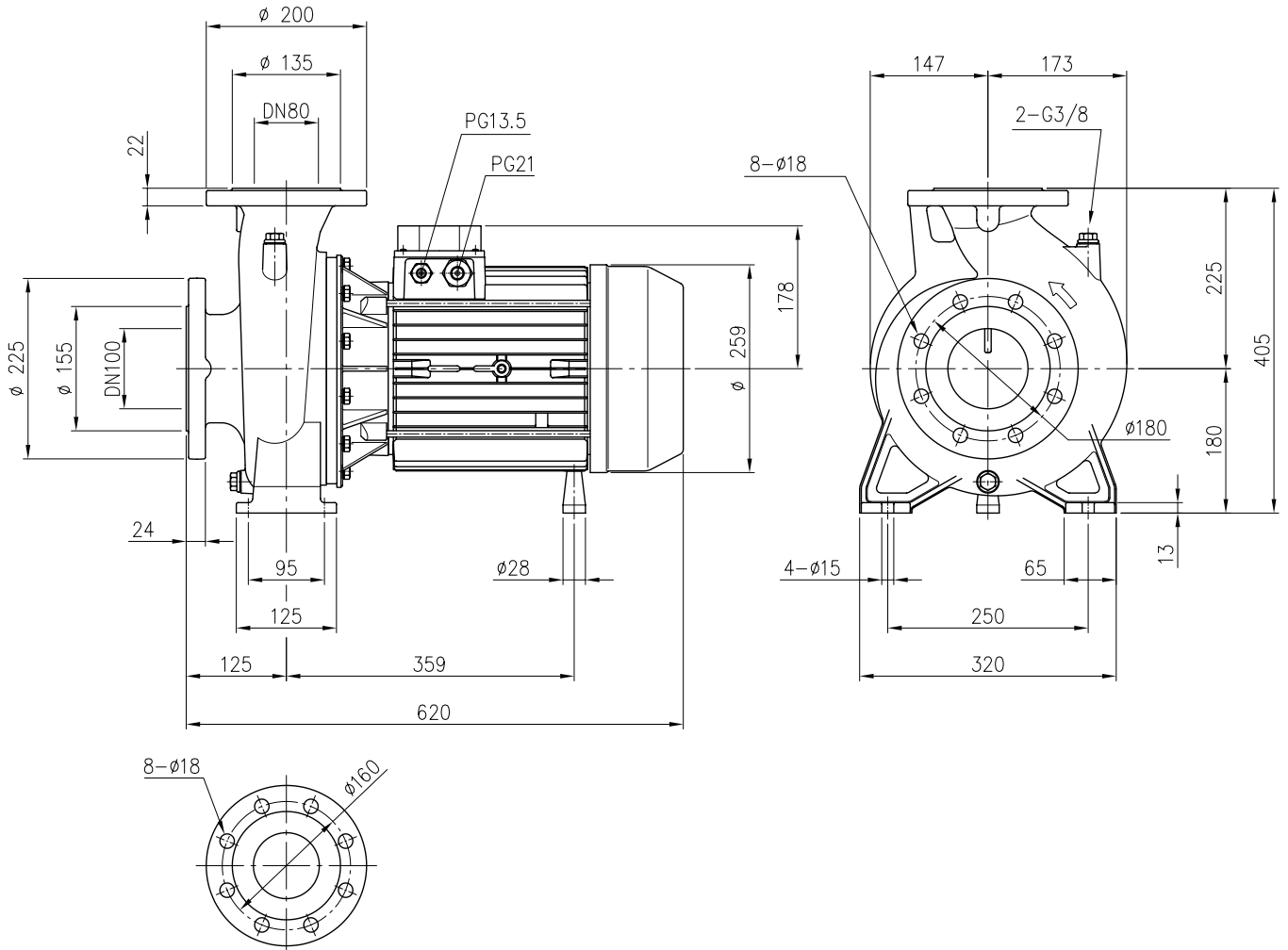

Weight: 100 kgf

PUMP 3LM 80-160/15R/15/18.5

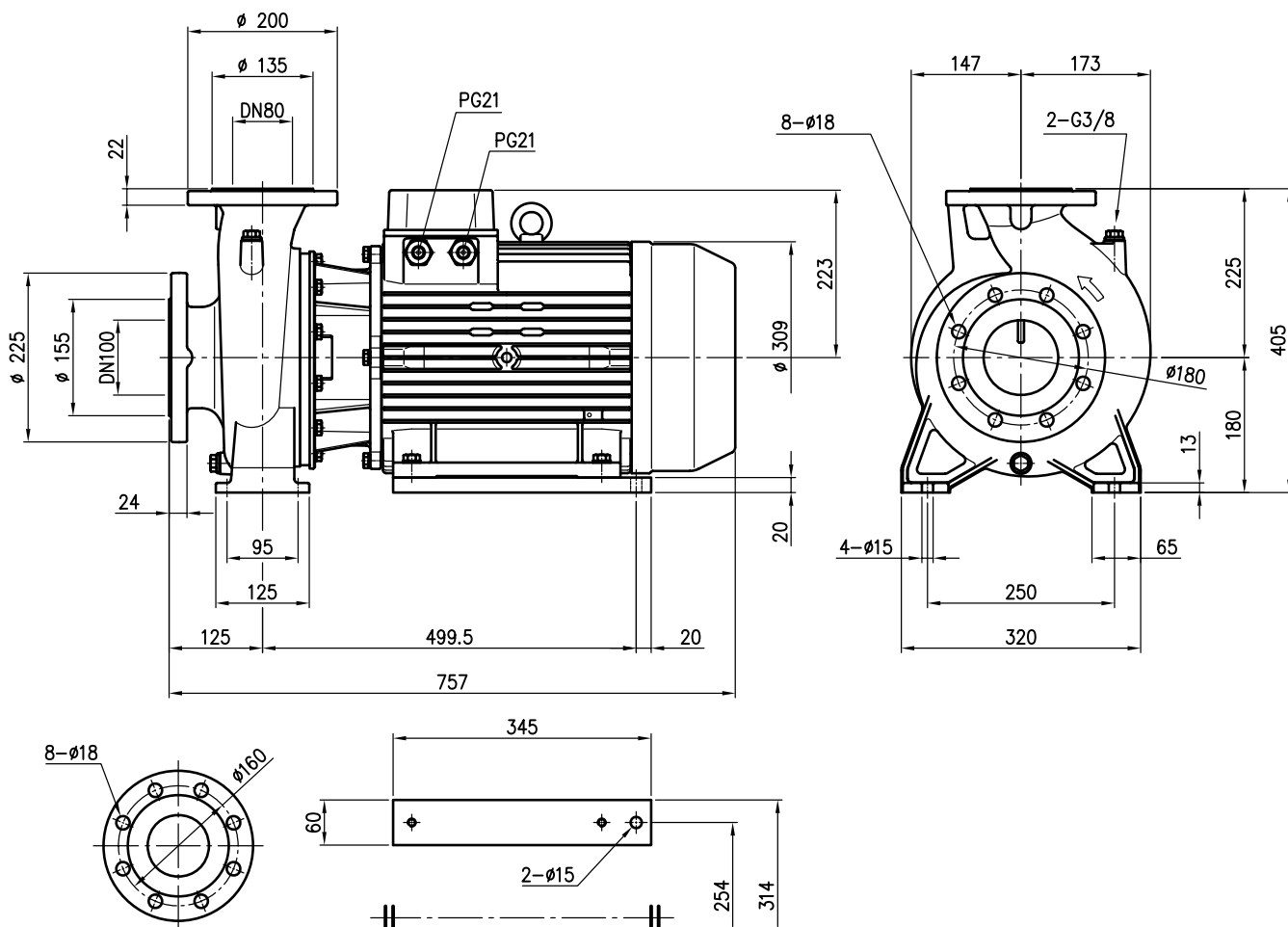

Weight:

80-160/15R :	130.1 kgf
80-160/15 :	131.1 kgf
80-160/18.5 :	145.3 kgf

PUMP 3(.).S 32, 40, 50

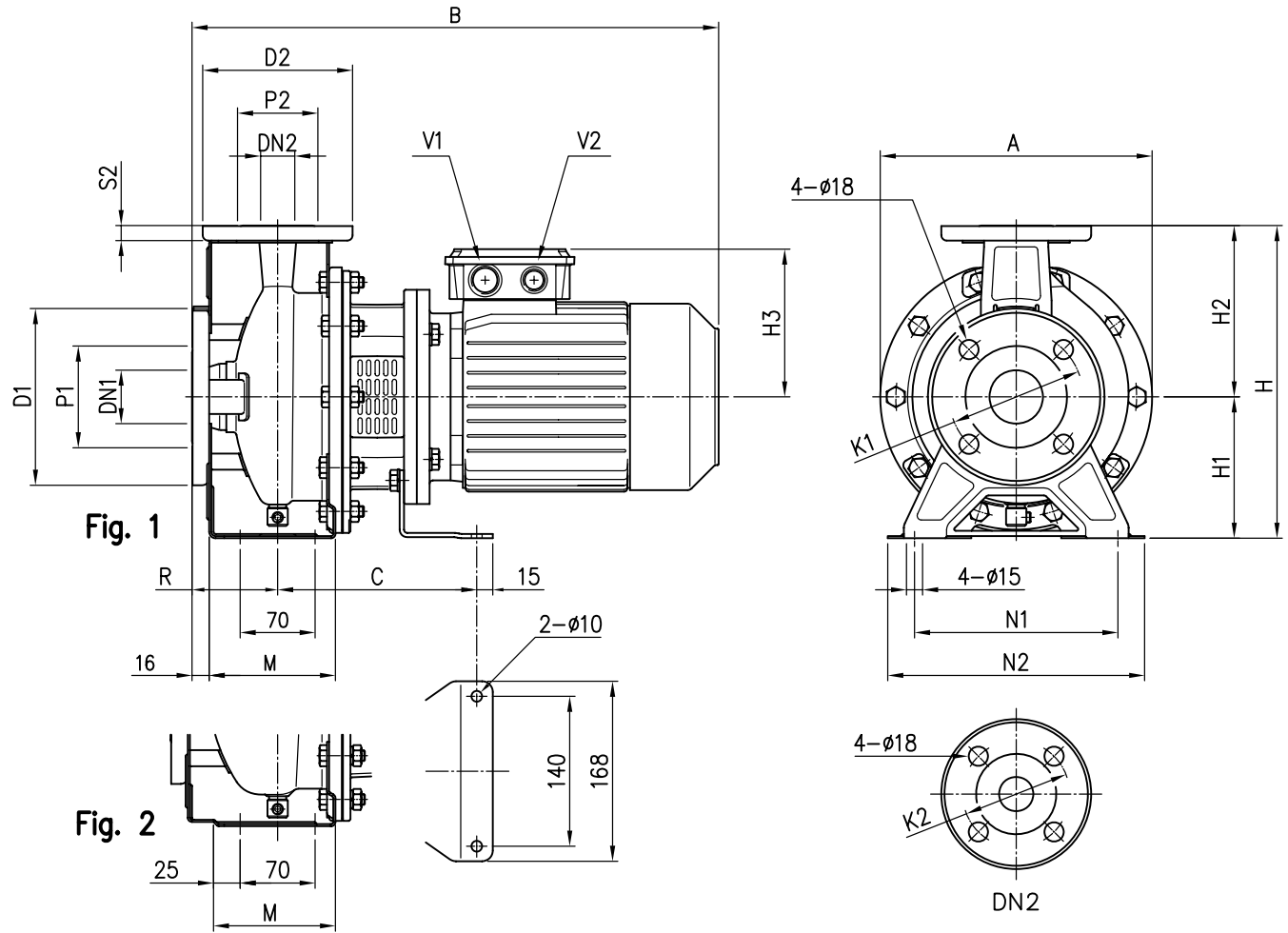

Model	Dimensions [mm]																				Weight Kgf			
	∅ DN1	∅ P1	∅ K1	∅ D1	∅ DN2	∅ P2	∅ K2	∅ D2	S2	Fig.	H	H1	H2	H3	R	M	N1	N2	A	B		C	V1	V2
32-125/1.1	50	95	125	165	32	75	100	140	14	1	252	112	140	139	80	114	140	190	213	430	174	M25x1.5	M20x1.5	24.7
32-160/1.5	50	95	125	165	32	75	100	140	14	1	292	132	160	148	80	118	190	240	254	477	186	M25x1.5	M20x1.5	29.8
32-160/2.2	50	95	125	165	32	75	100	140	14	1	292	132	160	148	80	118	190	240	254	477	186	M25x1.5	M20x1.5	32.4
40-125/1.5	65	115	145	185	40	80	110	150	14	1	252	112	140	148	80	114	160	210	213	477	186	M25x1.5	M20x1.5	26.5
40-125/2.2	65	115	145	185	40	80	110	150	14	1	252	112	140	148	80	114	160	210	213	477	186	M25x1.5	M20x1.5	29.6
50-125/2.2	65	115	145	185	50	95	125	165	16	2	292	132	160	148	100	114	190	240	254	497	186	M25x1.5	M20x1.5	32.9

PUMP 3(.)S 32, 65

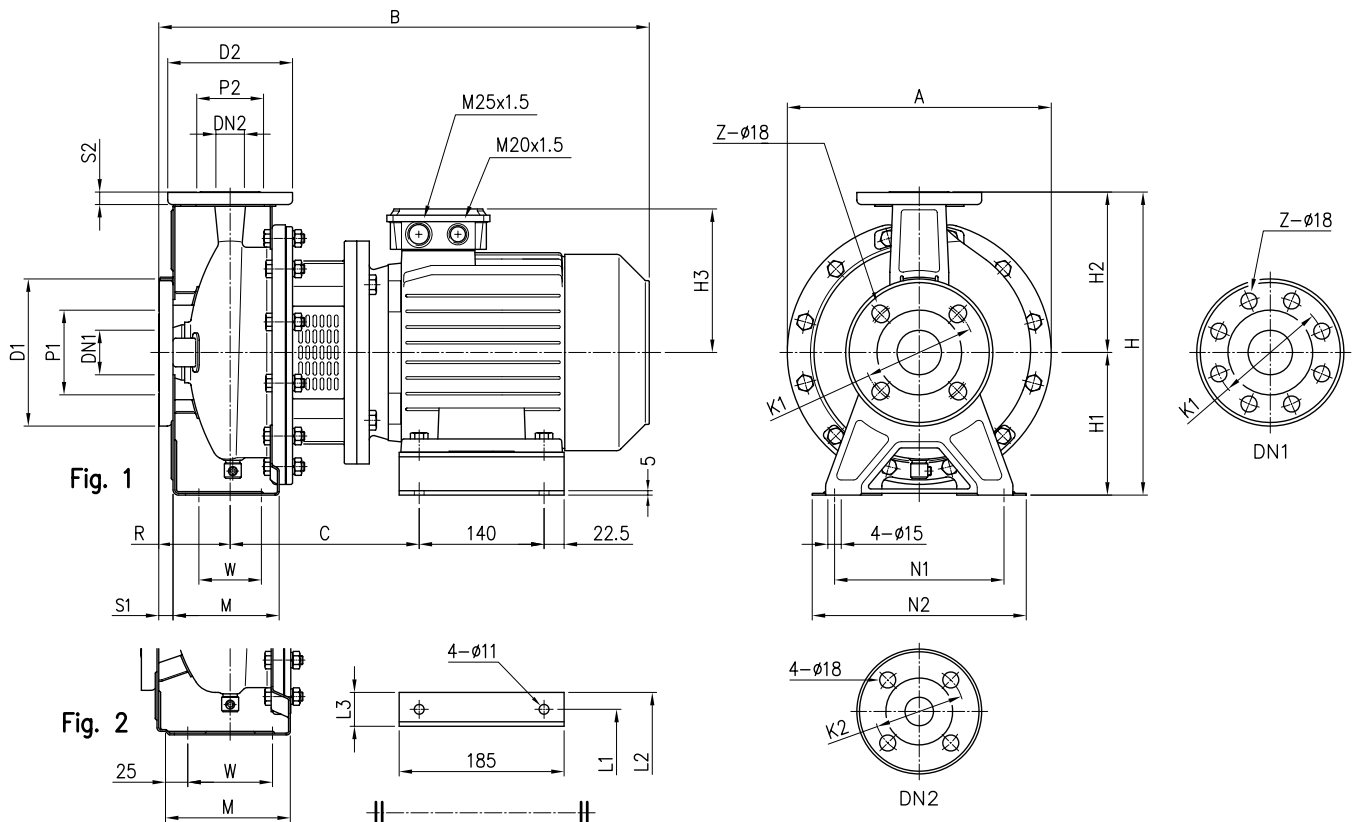

Model	Dimensions [mm]																				Weight Kgf								
	∅ DN1	∅ P1	∅ K1	∅ D1	S1	Z	[1]	[2]	∅ DN2	∅ P2	∅ K2	∅ D2	S2	Fig.	H	H1	H2	H3	R	W		M	N1	N2	A	B	C	L1	L2
32-200/3.0	50	95	125	165	16	4	-	32	75	100	140	14	1	340	160	180	155	80	70	119	190	240	296	528	205	160	202	42	46.9
32-200/4.0	50	95	125	165	16	4	-	32	75	100	140	14	1	340	160	180	171	80	70	119	190	240	296	550	212	190	228	38	49
65-125/4.0	80	134	160	200	18	8	4	65	115	145	185	16	2	340	160	180	171	100	95	140	212	280	254	570	212	190	228	38	50.1

[1] Standard [2] On request

PUMP 3(.)S 32, 40, 50, 65

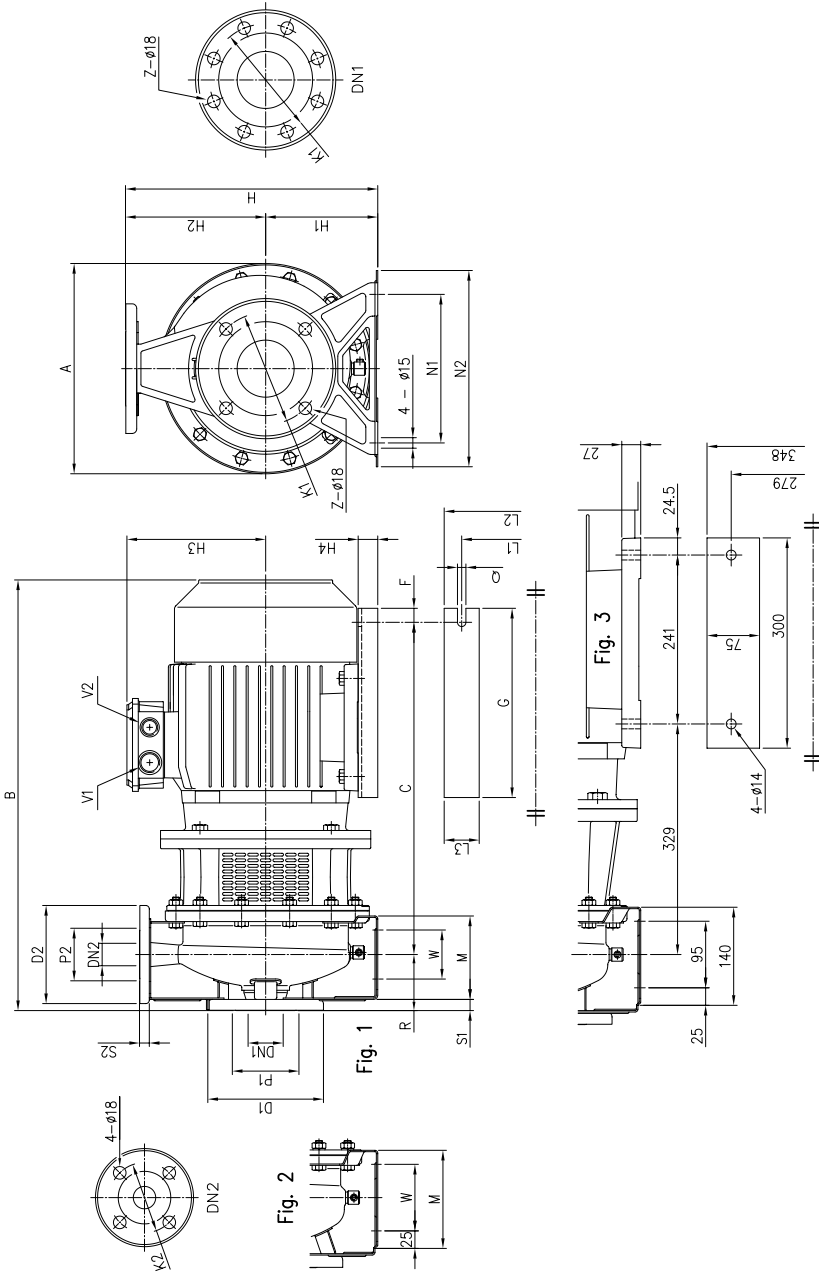

Model	Dimensions [mm]																Weight [kg]																			
	Ø DN1	Ø P1	Ø K1	Ø D1	S1	Z	Ø DN2	Ø P2	Ø K2	Ø D2	S2	Fig.	H	H1	H2	H3		H4	R	W	M	N1	N2	A	B	C	F	G	Q	L1	L2	L3	V1	V2		
32-200/5.5	50	95	125	165	16	4	-	32	75	100	140	14	1	340	160	180	198	28	80	70	119	190	240	300	607	479	15	270	12	216	266	50	M32x1.5	M32x1.5	71.8	
32-200/7.5	50	95	125	165	16	4	-	32	75	100	140	14	1	340	160	180	198	28	80	70	119	190	240	300	627	479	15	270	12	216	266	50	M32x1.5	M32x1.5	87	
40-160/3.0	65	115	145	185	16	4	-	40	80	110	150	14	1	292	132	160	155	32	80	70	118	190	240	254	528	388	15	220	12	160	200	40	M25x1.5	M20x1.5	42.5	
40-160/4.0	65	115	145	185	16	4	-	40	80	110	150	14	1	292	132	160	171	20	80	70	118	190	240	254	550	395	15	220	12	190	240	50	M25x1.5	M20x1.5	44.6	
40-200/5.5	65	115	145	185	16	4	-	40	80	110	150	14	2	340	160	180	198	28	100	70	115	212	265	300	627	479	15	270	12	216	266	50	M32x1.5	M32x1.5	72.2	
40-200/7.5	65	115	145	185	16	4	-	40	80	110	150	14	2	340	160	180	198	28	100	70	115	212	265	300	647	479	15	270	12	216	266	50	M32x1.5	M32x1.5	82	
50-125/3.0	65	115	145	185	16	4	-	50	95	125	165	16	2	292	132	160	155	32	100	70	114	190	240	254	548	388	15	220	12	160	200	40	M25x1.5	M20x1.5	35.5	
50-125/4.0	65	115	145	185	16	4	-	50	95	125	165	16	2	292	132	160	171	20	100	70	114	190	240	254	570	395	15	220	12	190	240	50	M25x1.5	M20x1.5	45.6	
50-160/5.5	65	115	145	185	16	4	-	50	95	125	165	16	2	340	160	180	198	28	100	70	115	212	265	300	627	479	15	270	12	216	266	50	M32x1.5	M32x1.5	63.8	
50-160/7.5	65	115	145	185	16	4	-	50	95	125	165	16	2	340	160	180	198	28	100	70	115	212	265	300	667	479	15	270	12	216	266	50	M32x1.5	M32x1.5	91	
50-200/9.2	65	115	145	185	16	4	-	50	95	125	165	16	2	360	160	200	198	28	100	70	115	212	265	300	667	479	15	270	12	216	266	50	M32x1.5	M32x1.5	90.7	
65-125/5.5	80	134	160	200	18	8	4	65	115	145	185	16	2	340	160	180	198	28	100	95	140	212	280	300	627	479	15	270	12	216	266	50	M32x1.5	M32x1.5	60	
65-125/7.5	80	134	160	200	18	8	4	65	115	145	185	16	2	340	160	180	198	28	100	95	140	212	280	300	647	479	15	270	12	216	266	50	M32x1.5	M32x1.5	79.4	
65-160/7.5	80	134	160	200	18	8	4	65	115	145	185	16	2	360	160	200	198	28	100	95	140	212	280	300	647	479	15	270	12	216	266	50	M32x1.5	M32x1.5	82.4	
65-160/9.2	80	134	160	200	18	8	4	65	115	145	185	16	2	360	160	200	198	28	100	95	140	212	280	300	667	479	15	270	12	216	266	50	M32x1.5	M32x1.5	88	
65-200/15	80	134	160	200	18	8	4	65	115	145	185	16	2	405	180	225	238	20	100	95	140	250	320	350	806	621	20	350	14	254	314	60	M40x1.5	M40x1.5	138	
65-200/18.5	80	134	160	200	18	8	4	65	115	145	185	16	2	405	180	225	238	20	100	95	140	250	320	350	850	621	20	350	14	254	314	60	M40x1.5	M40x1.5	137.2	
65-200/22	80	134	160	200	18	8	4	65	115	145	185	16	3	405	180	225	268	-	100	-	-	250	320	350	885	-	-	-	-	-	-	-	-	M32x1.5	M32x1.5	175

[1] Standard [2] On request

PUMP 3(.)S 40, 50, 65

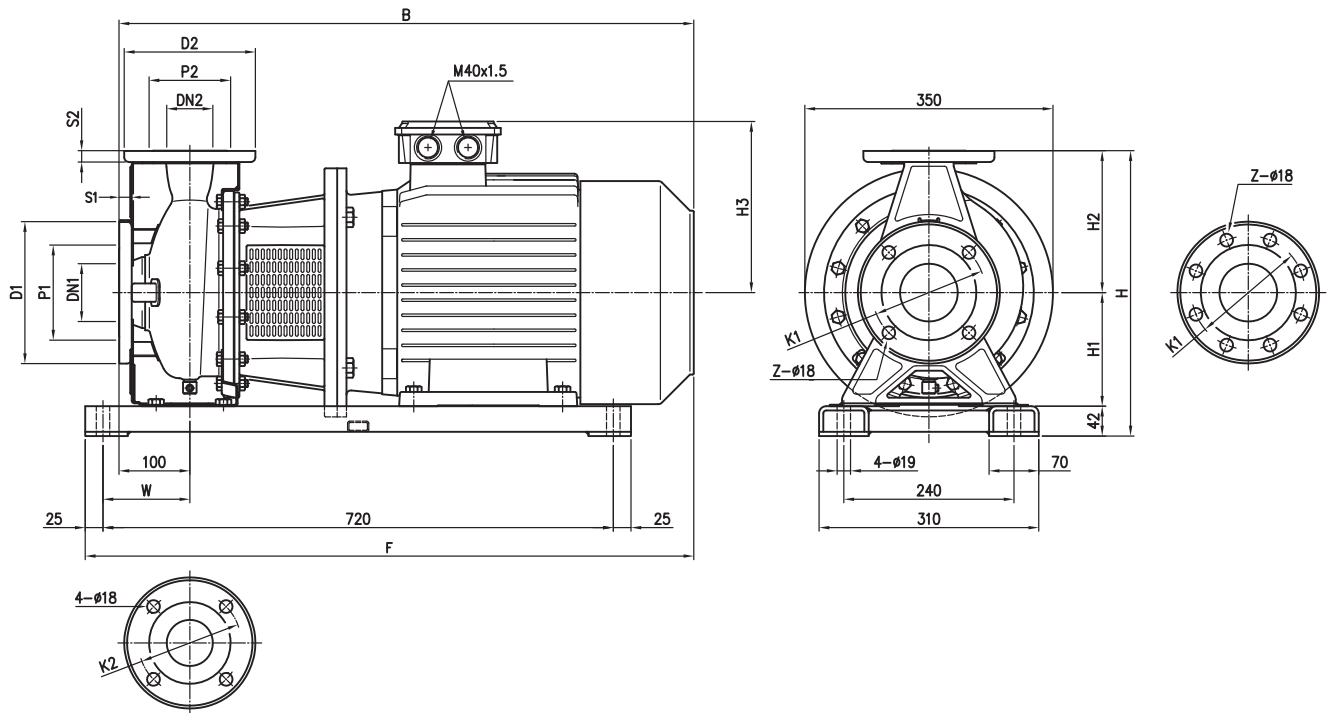

Pump type	Dimensions [mm]																			Weight [kgf]
	Ø DN1	Ø P1	Ø K1	Ø D1	S1	Z [1]	Z [2]	Ø DN2	Ø P2	Ø K2	Ø D2	S2	H	H1	H2	H3	W	B	F	
40-200/11	65	115	145	185	16	4	-	40	80	110	150	14	382	160	180	238	110	796	831	117.8
50-200/11	65	115	145	185	16	4	-	50	95	125	165	16	402	160	200	238	110	796	831	117.8
50-200/15	65	115	145	185	16	4	-	50	95	125	165	16	402	160	200	238	110	796	831	147.9
65-160/11	80	134	160	200	18	8	4	65	115	145	185	16	402	160	200	238	122.5	796	844	86.8
65-160/15	80	134	160	200	18	8	4	65	115	145	185	16	402	160	200	238	122.5	806	854	120.9

[1] Standard [2] On request

PUMP 3LSZ 32-125/160, 32-200/3/4, 50-125/2.2, 65-125/4

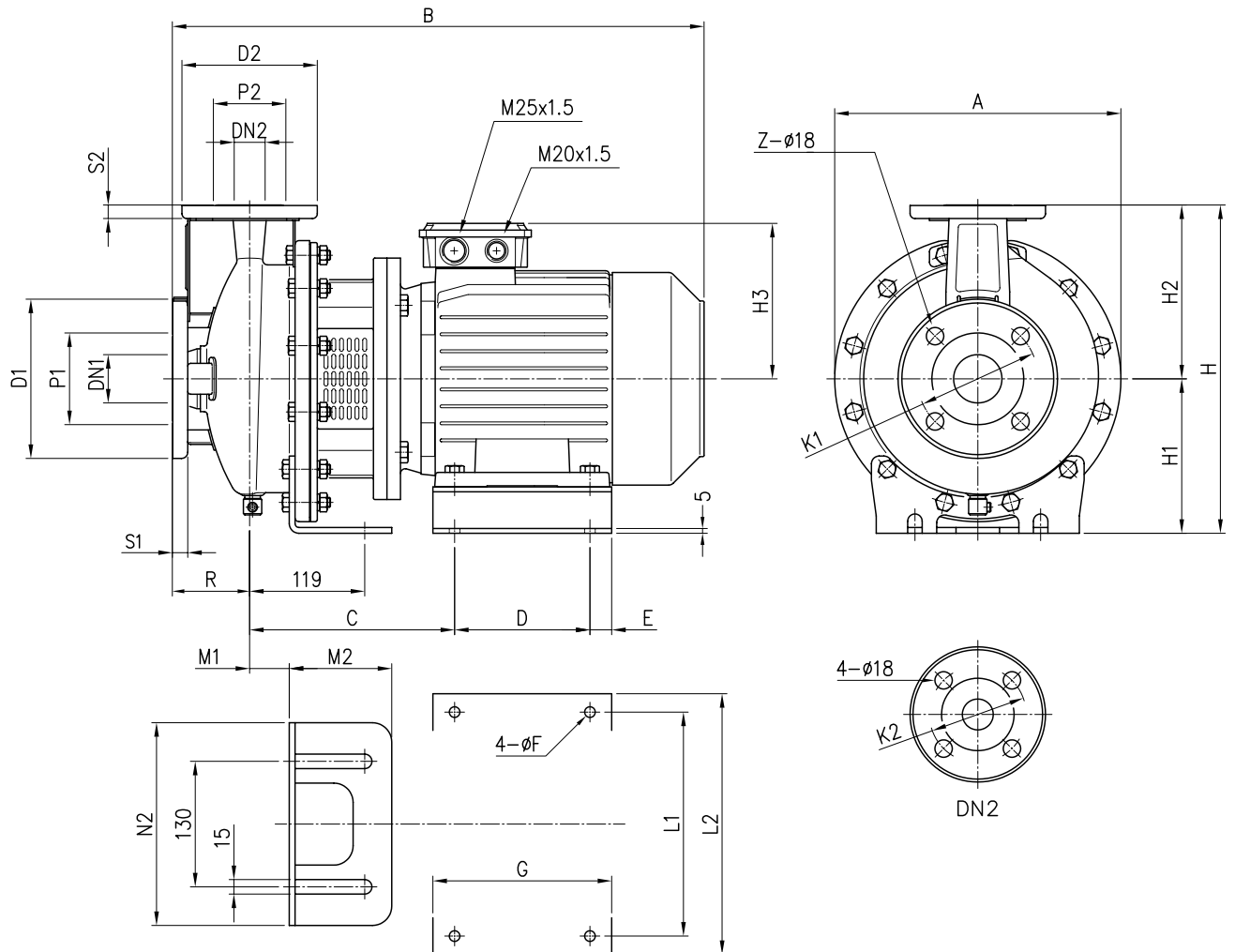

Model	Dimensions [mm]																				Weight								
	∅ DN1	∅ P1	∅ K1	∅ D1	S1	Z	∅ DN2	∅ P2	∅ K2	∅ D2	S2	H	H1	H2	H3	R	A	B	C	D	E	∅ F	G	L1	L2	M1	M2	N2	Kgf
32-125/1.1	50	95	125	165	16	4	32	75	100	140	14	252	112	140	139	80	213	430	168	100	15	9	130	205	225	32,5	117	190	24.7
32-160/1.5	50	95	125	165	16	4	32	75	100	140	14	292	132	160	148	80	254	477	186	125	25	9	170	210	230	42	105	210	29.8
32-160/2.2	50	95	125	165	16	4	32	75	100	140	14	292	132	160	148	80	254	477	186	125	25	9	170	210	230	42	105	210	32.4
32-200/3.0	50	95	125	165	16	4	32	75	100	140	14	340	160	180	155	80	296	528	205	140	22,5	11	185	160	202	41	106	210	46.9
32-200/4.0	50	95	125	165	16	4	32	75	100	140	14	340	160	180	171	80	296	550	212	140	22,5	11	185	190	228	41	106	210	49
50-125/2.2	65	115	145	185	16	4	50	95	125	165	16	292	132	160	148	100	254	497	186	125	25	9	170	210	230	42	105	210	32.9
65-125/4.0	80	134	160	200	18	8	65	115	145	185	16	340	160	180	171	100	254	570	212	140	22,5	11	185	190	228	42	105	210	50.1

**PUMP 3LSZ 32-200/5.5/7.5, 40-125/160, 40-200/5.5/7.5, 50-125/3/4, 50-160
50-200/9.2, 65-125/5.5/7.5, 65-160/7.5/9.2**

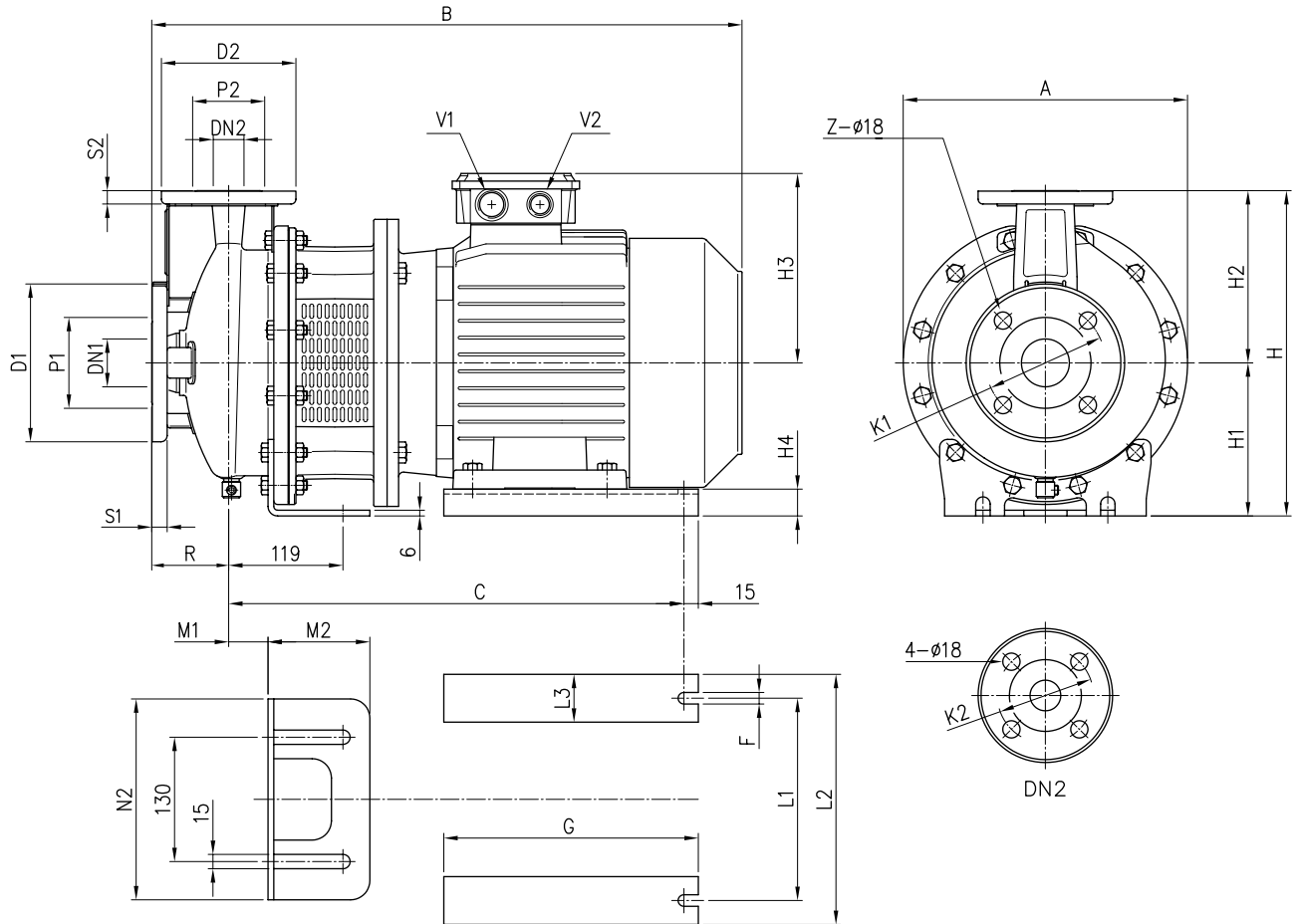

Model	Dimensions [mm]																										Weight Kgf		
	∅ DN1	∅ P1	∅ K1	∅ D1	S1	Z	∅ DN2	∅ P2	∅ K2	∅ D2	S2	H	H1	H2	H3	H4	R	A	B	C	F	G	L1	L2	L3	M1		M2	N2
32-200/5.5	50	95	125	165	16	4	32	75	100	140	14	340	160	180	198	28	80	300	607	479	12	270	216	266	50	41	106	210	71.8
32-200/7.5	50	95	125	165	16	4	32	75	100	140	14	340	160	180	198	28	80	300	627	479	12	270	216	266	50	41	106	210	87
40-125/1.5	65	115	145	185	16	4	40	80	110	150	14	252	112	140	148	22	80	213	477	342	10	186	140	185	45	32.5	117	190	26.5
40-125/2.2	65	115	145	185	16	4	40	80	110	150	14	252	112	140	148	22	80	213	477	342	10	186	140	185	40	32.5	117	190	29.5
40-160/3.0	65	115	145	185	16	4	40	80	110	150	14	292	132	160	155	32	80	254	528	387.5	12	220	160	200	50	42	105	210	42.5
40-160/4.0	65	115	145	185	16	4	40	80	110	150	14	292	132	160	171	20	80	254	550	394.5	12	220	190	240	50	42	105	210	44.6
40-200/5.5	65	115	145	185	16	4	40	80	110	150	14	340	160	180	198	28	100	300	627	479	12	270	216	266	50	41	106	210	72.2
40-200/7.5	65	115	145	185	16	4	40	80	110	150	14	340	160	180	198	28	100	300	647	479	12	270	216	266	40	41	106	210	82
50-125/3.0	65	115	145	185	16	4	50	95	125	165	16	292	132	160	155	32	100	254	548	387.5	12	220	160	200	50	42	105	210	35.5
50-125/4.0	65	115	145	185	16	4	50	95	125	165	16	292	132	160	171	20	100	254	570	394.5	12	220	190	240	50	42	105	210	45.6
50-160/5.5	65	115	145	185	16	4	50	95	125	165	16	340	160	180	198	28	100	300	627	479	12	270	216	266	50	41	106	210	63.8
50-160/7.5	65	115	145	185	16	4	50	95	125	165	16	340	160	180	198	28	100	300	647	479	12	270	216	266	50	41	106	210	91
50-200/9.2	65	115	145	185	16	4	50	95	125	165	16	360	160	200	198	28	100	300	667	479	12	270	216	266	50	41	106	210	90.7
65-125/5.5	80	134	160	200	18	8	65	115	145	185	16	340	160	180	198	28	100	300	627	479	12	270	216	266	50	42	105	210	60
65-125/7.5	80	134	160	200	18	8	65	115	145	185	16	340	160	180	198	28	100	300	647	479	12	270	216	266	50	42	105	210	79.4
65-160/7.5	80	134	160	200	18	8	65	115	145	185	16	360	160	200	198	28	100	300	647	479	12	270	216	266	50	41	106	210	82.4
65-160/9.2	80	134	160	200	18	8	65	115	145	185	16	360	160	200	198	28	100	300	667	479	12	270	216	266	50	41	106	210	88

PUMP 3LSZ 40-200/11, 50-200/11/15, 65-160/11/15, 65-200

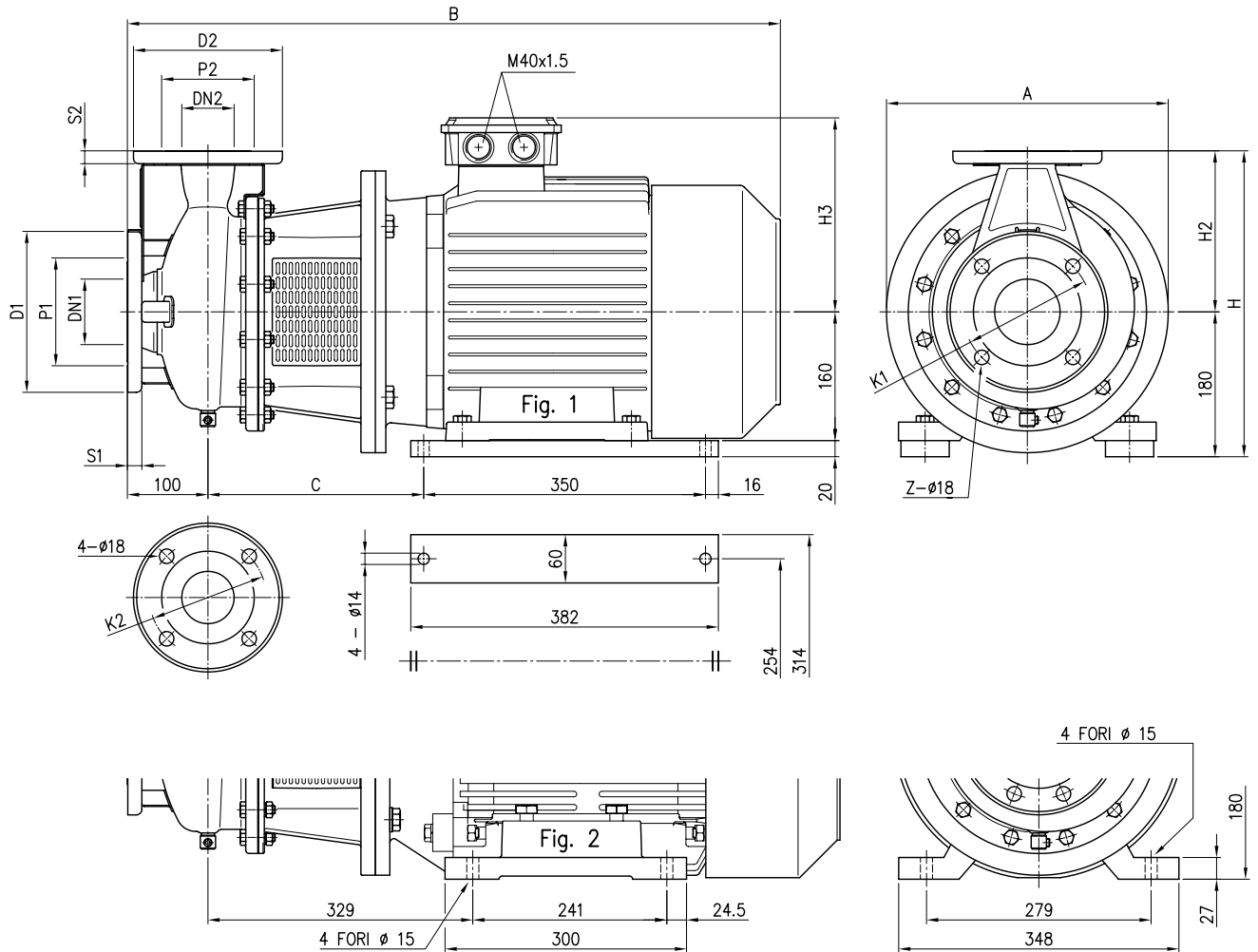

Model	Dimensions [mm]													Fig.	H	H2	H3	A	B	C	Weight [kgf]
	∅ DN1	∅ P1	∅ K1	∅ D1	S1	Z	∅ DN2	∅ P2	∅ K2	∅ D2	S2										
40-200/11	65	115	145	185	16	4	40	80	110	150	14	1	360	180	238	350	796	258	117.8		
50-200/11	65	115	145	185	16	4	50	95	125	165	16	1	380	200	238	350	796	258	117.8		
50-200/15	65	115	145	185	16	4	50	95	125	165	16	1	380	200	238	350	796	258	147.9		
65-160/11	80	134	160	200	18	8	65	115	145	185	16	1	380	200	238	350	796	258	86.8		
65-160/15	80	134	160	200	18	8	65	115	145	185	16	1	380	200	238	350	806	268	120.9		
65-200/15	80	134	160	200	18	8	65	115	145	185	16	1	405	225	238	350	806	268	138		
65-200/18.5	80	134	160	200	18	8	65	115	145	185	16	1	405	225	238	350	850	268	137.2		
65-200/22	80	134	160	200	18	8	65	115	145	185	16	2	405	225	268	360	885	-	175		

PUMP 3LS 80-160

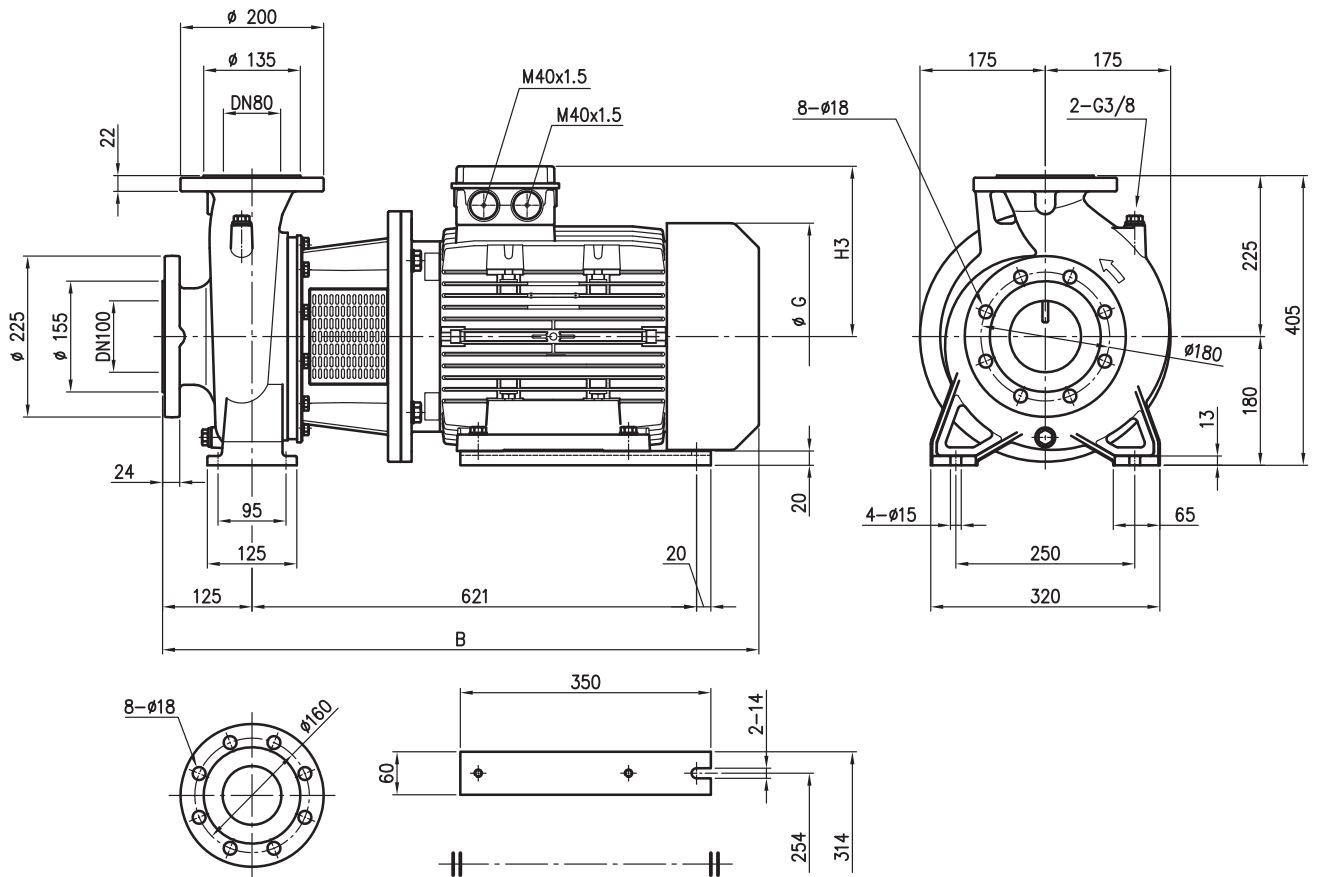

Pump type	B	H3	G	Weight [kgf]
80-160/11	831	238	317	145.8
80-160/15R	831	238	317	157
80-160/15	831	238	317	157
80-160/18.5	875	238	317	151.2

PUMP 3LS 65-250, 80-200, 80-250/37

Pump type	Dimensions [mm]																												Weight [kgf]									
	DN1	P1	K1	D1	S1	DN2	P2	D2	S2	H	H1	H2	H3	H4	H5	R	W	N1	N2	M	M1	L	L1	L2	L3	L5	A1	A2		B	C	F1	G	D3	D5	V1	V2	
65-250/30	80	135	160	200	22	65	Fig. 1	120	185	20	450	200	250	300	15	25	100	120	280	360	160	80	305	318	388	80	358	200	200	966	341	21.5	399	19	17	M40x1.5	M40x1.5	303
65-250/37	80	135	160	200	22	65	Fig. 1	120	185	20	450	200	250	300	15	25	100	120	280	360	160	80	305	318	388	80	358	200	200	966	341	21.5	399	19	17	M40x1.5	M40x1.5	320
80-200/22	100	155	180	225	24	80	Fig. 2	135	200	22	430	180	250	268	13	27	125	95	280	345	125	65	241	273	348	75	300	175	182	910	329	24.5	360	15	14	M32x1.5	M32x1.5	207
80-250/37	100	155	180	225	24	80	Fig. 2	135	200	22	480	200	280	300	15	25	125	120	315	400	160	80	305	318	388	80	358	200	200	1019	368	21.5	399	19	17	M40x1.5	M40x1.5	335

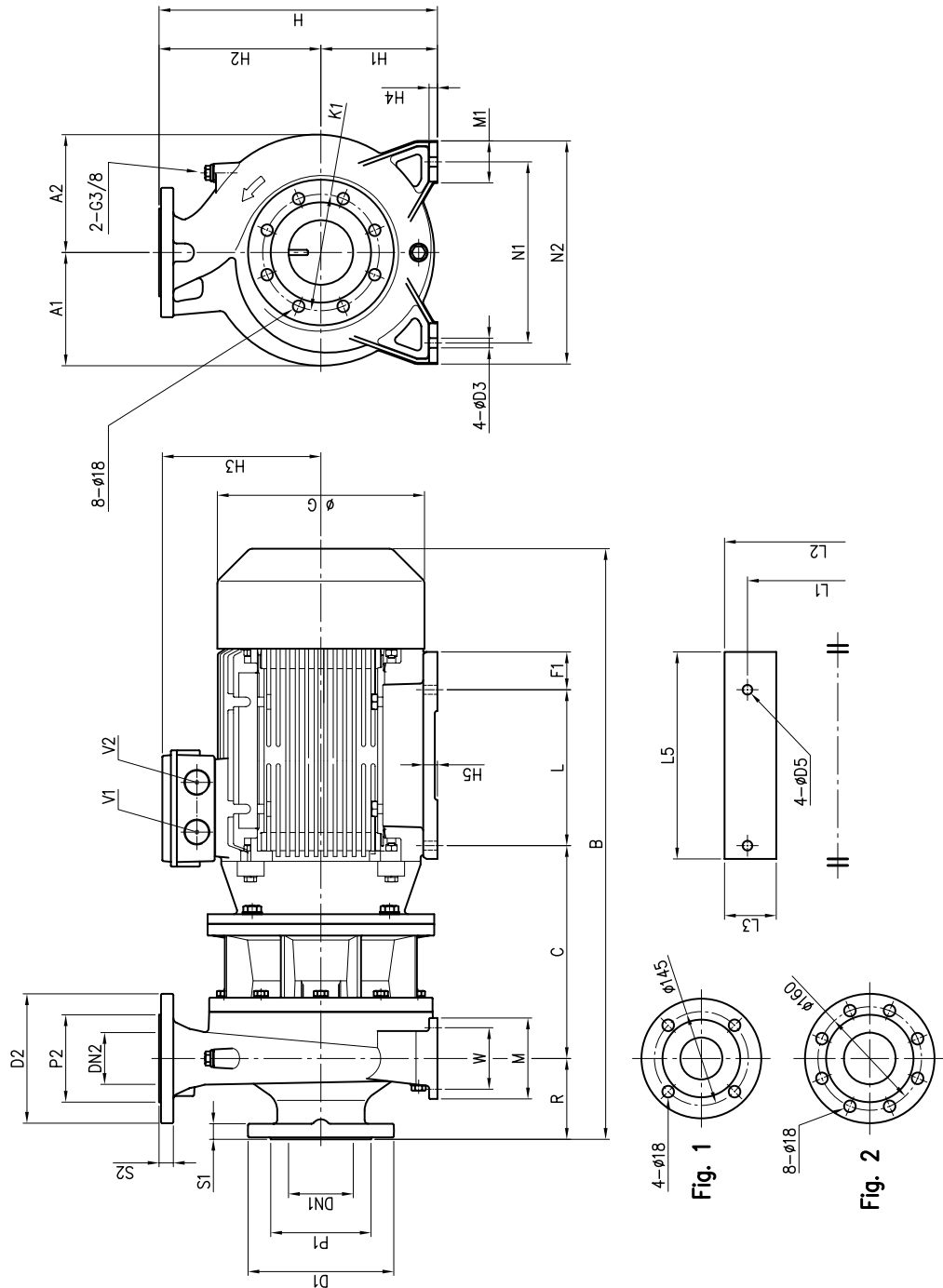

PUMP 3LS 80-200/30/37, 80-250/45

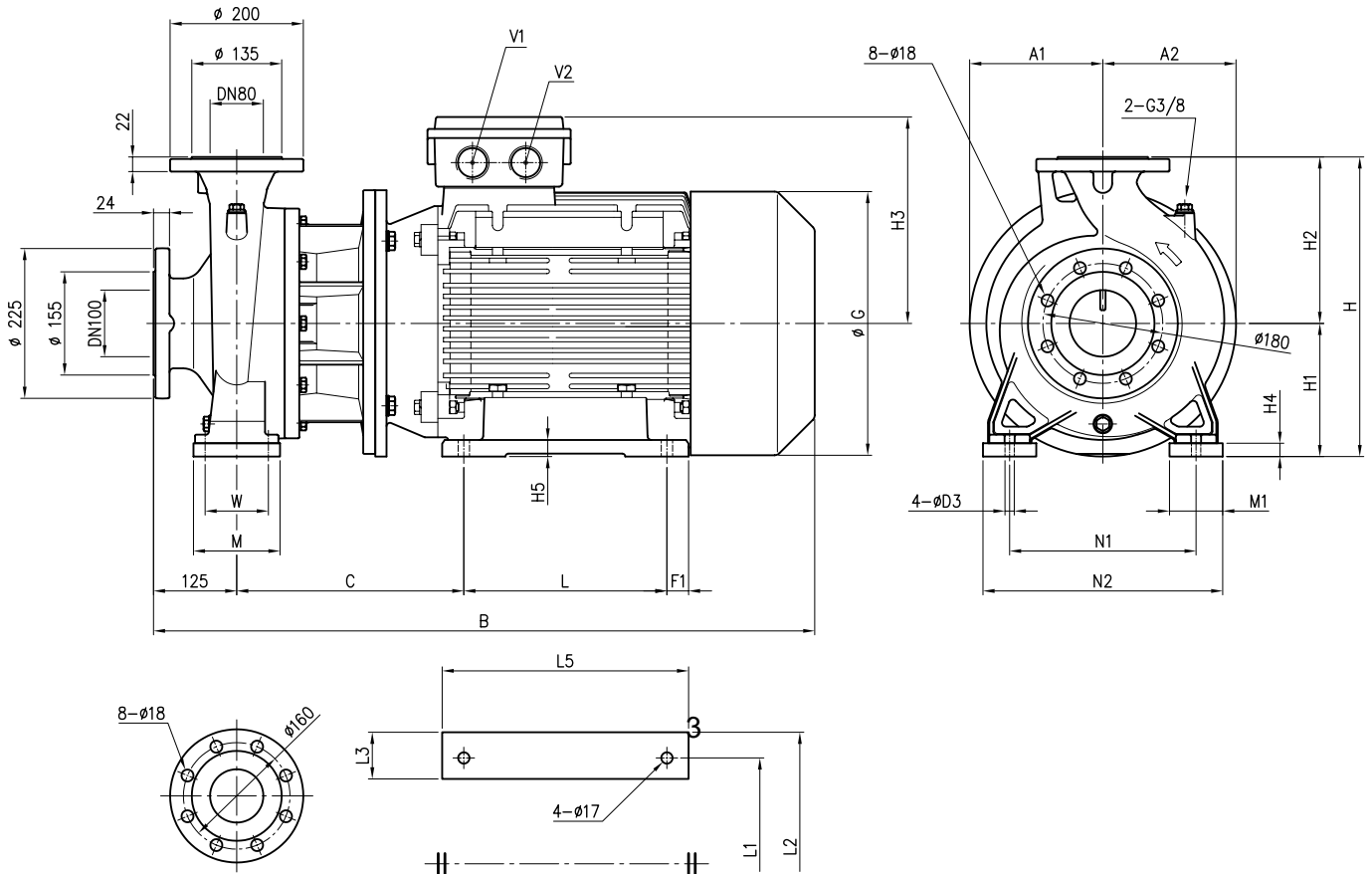

Pump type	Dimensions [mm]																				Weight [kg]					
	H	H1	H2	H3	H4	H5	W	N1	N2	M	M1	L	L1	L2	L3	L5	A1	A2	B	C		F1	G	D3	V1	V2
80-200/30	450	200	250	300	20	25	95	280	360	130	80	305	318	388	80	358	200	200	991	341	21.5	399	14	M40x1.5	M40x1.5	306
80-200/37	450	200	250	300	20	25	95	280	360	130	80	305	318	388	80	358	200	200	991	341	21.5	399	14	M40x1.5	M40x1.5	325
80-250/45	505	225	280	335	25	28	120	315	415	165	100	311	356	436	80	386	225	225	1060	385	37.5	465	18	M50x1.5	M50x1.5	401

PUMP 3LS 80-250/55

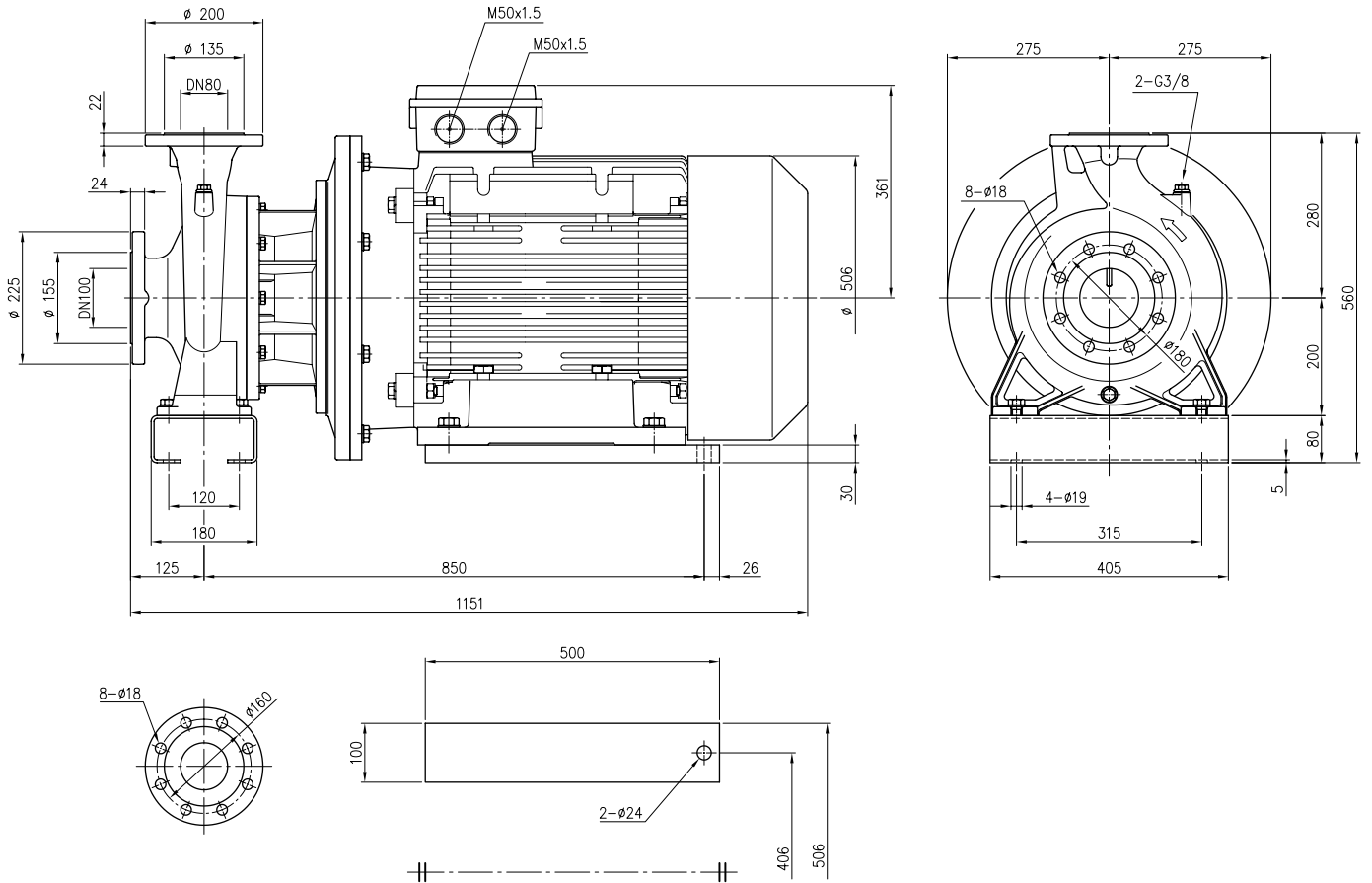

Weight: 489 kgf

PUMP 3(.)P 32, 40, 50, 65

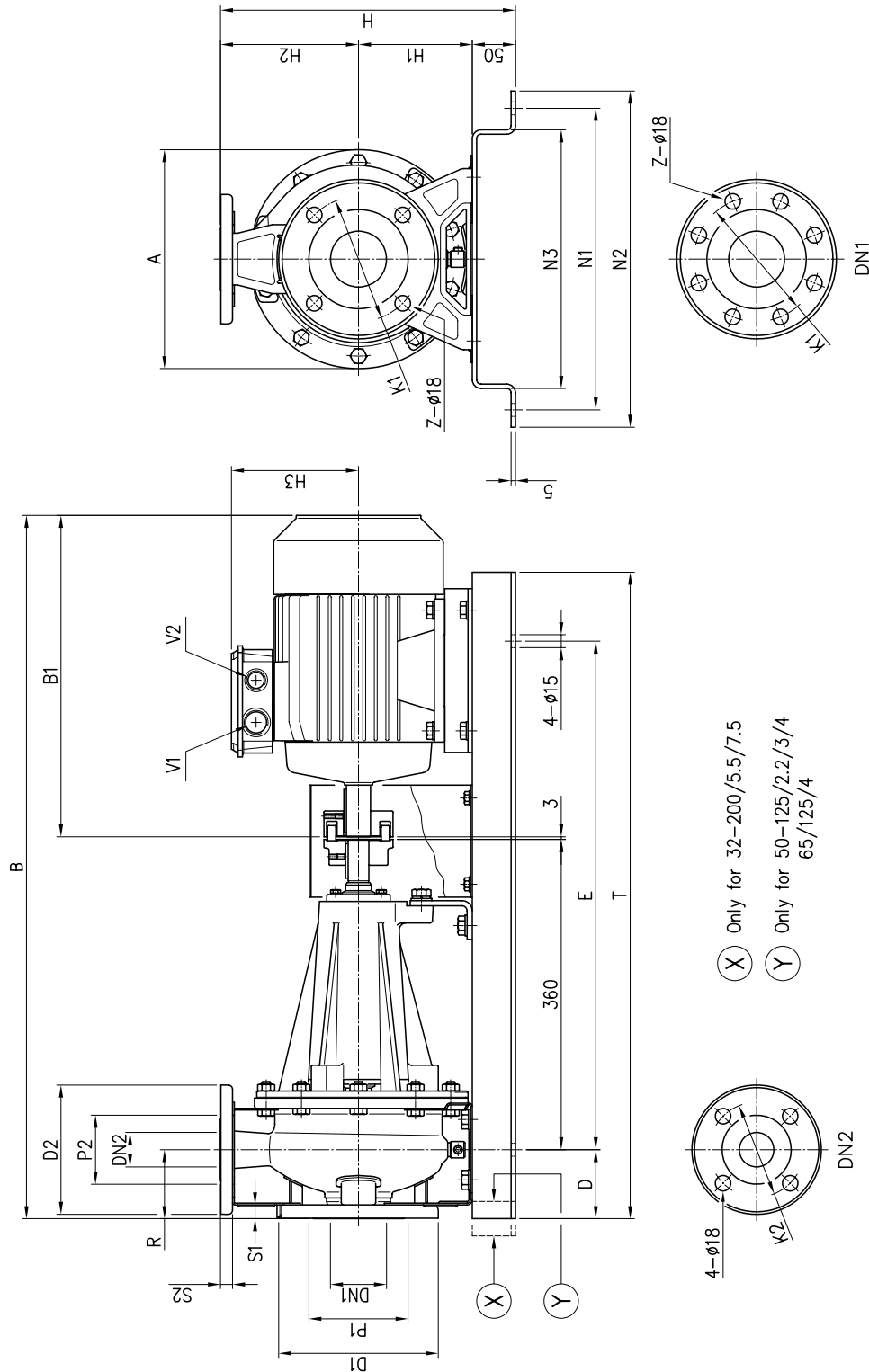

For dimensions see table pag. 418

DIMENSIONS AND WEIGHT

50Hz

Rev. AC

PUMP 3(.)P 32, 40, 50, 65

Dimensions [mm]																				Weight									
DN	Ø P1	Ø K1	Ø D1	Ø S1	Z	Ø DN2	Ø P2	Ø K2	Ø D2	S2	H	H1	H2	H3	R	A	B	B1	D	E	N1	N2	N3	T	V1	V2	Weight		
Ø	Ø	Ø	Ø	Ø	Ø	Ø	Ø	Ø	Ø	Ø	Ø	Ø	Ø	Ø	Ø	Ø	Ø	Ø	Ø	Ø	Ø	Ø	Ø	Ø	Ø	Ø	Ø	Kgf	
50	95	##	##	165	16	4	-	32	75	##	##	14	##	##	140	139	80	213	715	##	80	550	300	340	250	710	M25x1.5	M20x1.5	45.1
50	95	##	##	165	16	4	-	32	75	##	##	14	##	##	160	148	80	254	760	##	80	590	350	390	300	750	M25x1.5	M20x1.5	52.3
50	95	##	##	165	16	4	-	32	75	##	##	14	##	##	160	148	80	254	760	##	80	590	350	390	300	750	M25x1.5	M20x1.5	53.5
50	95	##	##	165	16	4	-	32	75	##	##	14	##	##	180	155	80	296	809	##	80	590	350	390	300	750	M25x1.5	M20x1.5	71.5
50	95	##	##	165	16	4	-	32	75	##	##	14	##	##	180	171	80	296	831	##	80	590	350	390	300	750	M25x1.5	M20x1.5	75.1
50	95	##	##	165	16	4	-	32	75	##	##	14	##	##	180	198	80	296	885	##	##	650	350	390	300	850	M32x1.5	M32x1.5	97
50	95	##	##	165	16	4	-	32	75	##	##	14	##	##	180	198	80	296	885	##	##	650	350	390	300	850	M32x1.5	M32x1.5	-
65	##	##	##	185	16	4	-	40	80	##	##	##	##	##	140	148	80	213	760	##	80	550	300	340	250	710	M25x1.5	M20x1.5	49.8
65	##	##	##	185	16	4	-	40	80	##	##	##	##	##	140	148	80	213	760	##	80	550	300	340	250	710	M25x1.5	M20x1.5	51
65	##	##	##	185	16	4	-	40	80	##	##	##	##	##	160	155	80	254	809	##	80	590	350	390	300	750	M25x1.5	M20x1.5	81
65	##	##	##	185	16	4	-	40	80	##	##	##	##	##	160	171	80	254	831	##	80	590	350	390	300	750	M25x1.5	M20x1.5	67.6
65	##	##	##	185	16	4	-	40	80	##	##	##	##	##	180	198	##	296	905	##	##	650	350	390	300	850	M32x1.5	M32x1.5	98
65	##	##	##	185	16	4	-	40	80	##	##	##	##	##	180	198	##	296	905	##	##	650	350	390	300	850	M32x1.5	M32x1.5	-
65	##	##	##	185	16	4	-	40	80	##	##	##	##	##	180	238	##	296	##	##	##	800	380	420	330	##	M40x1.5	M40x1.5	-
65	##	##	##	185	16	4	-	50	95	##	##	##	##	##	160	148	##	254	780	##	80	550	350	390	300	710	M25x1.5	M20x1.5	75
65	##	##	##	185	16	4	-	50	95	##	##	##	##	##	160	155	##	254	829	##	80	590	350	390	300	750	M25x1.5	M20x1.5	82.5
65	##	##	##	185	16	4	-	50	95	##	##	##	##	##	160	171	##	254	851	##	80	590	350	390	300	750	M25x1.5	M20x1.5	84.6
65	##	##	##	185	16	4	-	50	95	##	##	##	##	##	180	198	##	296	905	##	##	650	350	390	300	850	M32x1.5	M32x1.5	98
65	##	##	##	185	16	4	-	50	95	##	##	##	##	##	180	198	##	296	905	##	##	650	350	390	300	850	M32x1.5	M32x1.5	-
65	##	##	##	185	16	4	-	50	95	##	##	##	##	##	180	198	##	296	905	##	##	650	350	390	300	850	M32x1.5	M32x1.5	-
65	##	##	##	185	16	4	-	50	95	##	##	##	##	##	200	198	##	296	945	##	##	650	350	390	300	850	M32x1.5	M32x1.5	-
65	##	##	##	185	16	4	-	50	95	##	##	##	##	##	200	238	##	296	##	##	##	800	380	420	330	##	M40x1.5	M40x1.5	-
65	##	##	##	185	16	4	-	50	95	##	##	##	##	##	200	238	##	296	##	##	##	800	380	420	330	##	M40x1.5	M40x1.5	-
80	##	##	##	200	18	8	4	65	115	##	##	##	##	##	180	171	##	254	851	##	80	590	350	390	300	750	M25x1.5	M20x1.5	85.1
80	##	##	##	200	18	8	4	65	115	##	##	##	##	##	180	198	##	254	905	##	##	650	350	390	300	850	M32x1.5	M32x1.5	99
80	##	##	##	200	18	8	4	65	115	##	##	##	##	##	180	198	##	254	905	##	##	650	350	390	300	850	M32x1.5	M32x1.5	-
80	##	##	##	200	18	8	4	65	115	##	##	##	##	##	200	198	##	296	905	##	##	650	350	390	300	850	M32x1.5	M32x1.5	-
80	##	##	##	200	18	8	4	65	115	##	##	##	##	##	200	198	##	296	945	##	##	650	350	390	300	850	M32x1.5	M32x1.5	-
80	##	##	##	200	18	8	4	65	115	##	##	##	##	##	200	238	##	296	##	##	##	800	380	420	330	##	M40x1.5	M40x1.5	-
80	##	##	##	200	18	8	4	65	115	##	##	##	##	##	200	238	##	296	##	##	##	800	380	420	330	##	M40x1.5	M40x1.5	-
80	##	##	##	200	18	8	4	65	115	##	##	##	##	##	225	238	##	296	##	##	##	800	380	420	330	##	M40x1.5	M40x1.5	-
80	##	##	##	200	18	8	4	65	115	##	##	##	##	##	225	238	##	296	##	##	##	800	380	420	330	##	M40x1.5	M40x1.5	-
80	##	##	##	200	18	8	4	65	115	##	##	##	##	##	225	268	##	296	##	##	##	800	410	450	360	##	M32x1.5	M32x1.5	-

[2] On request

PUMP 3LP 65-250, 80-160/200/250

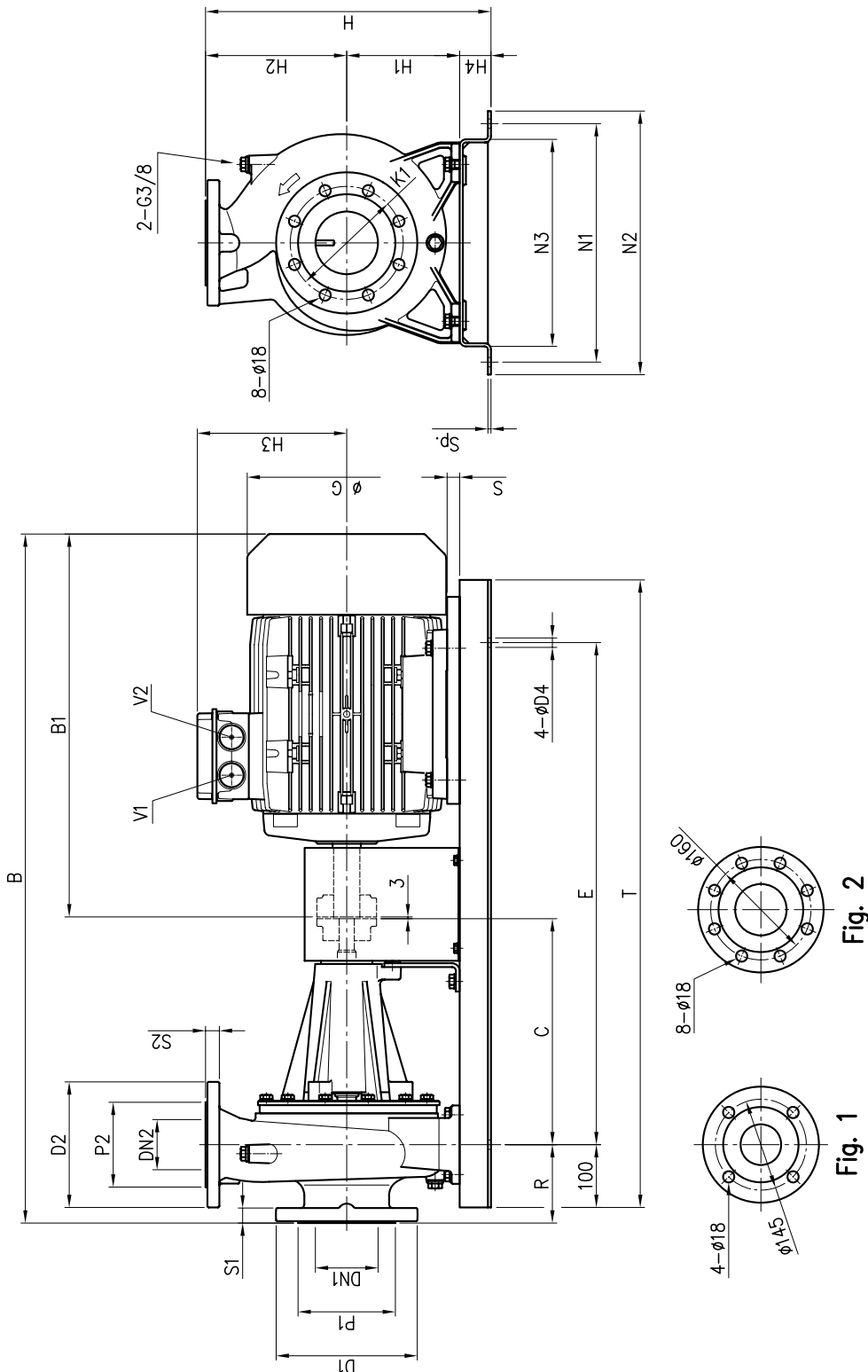

Pump type	Dimensions [mm]																				Weight [kgf]								
	DN1	P1	k1	D1	S1	DN2	P2	D2	S2	H	H1	H2	H3	H4	R	N1	N2	N3	B	B1		C	G	E	T	S	D4	Sp.	V1
65-250/30	80	135	160	200	22	65 Fig. 1	120	185	20	510	200	250	300	60	100	530	590	460	1341	768	470	399	###	-	19	8	M40x1.5	M40x1.5	354
65-250/37	80	135	160	200	22	65 Fig. 1	120	185	20	510	200	250	300	60	100	530	590	460	1341	768	470	399	###	-	19	8	M40x1.5	M40x1.5	373
80-160/11	100	155	180	225	24	80 Fig. 2	135	200	22	455	180	225	238	50	125	380	420	330	1096	608	360	317	800	###	20	15	M40x1.5	M40x1.5	174.8
80-160/15R	100	155	180	225	24	80 Fig. 2	135	200	22	455	180	225	238	50	125	380	420	330	1096	608	360	317	800	###	20	15	M40x1.5	M40x1.5	186
80-160/15	100	155	180	225	24	80 Fig. 2	135	200	22	455	180	225	238	50	125	380	420	330	1096	608	360	317	800	###	20	15	M40x1.5	M40x1.5	186
80-160/18.5	100	155	180	225	24	80 Fig. 2	135	200	22	455	180	225	238	50	125	380	420	330	1140	652	360	317	800	###	20	15	M40x1.5	M40x1.5	181.2
80-200/22	100	155	180	225	24	80 Fig. 2	135	200	22	490	180	250	268	60	125	530	590	460	1285	687	470	360	###	-	19	8	M32x1.5	M32x1.5	259
80-250/37	100	155	180	225	24	80 Fig. 2	135	200	22	540	200	280	300	60	125	530	590	460	1366	768	470	399	###	-	19	8	M40x1.5	M40x1.5	377

PUMP 3LP 80-200/30/37, 80-250/45

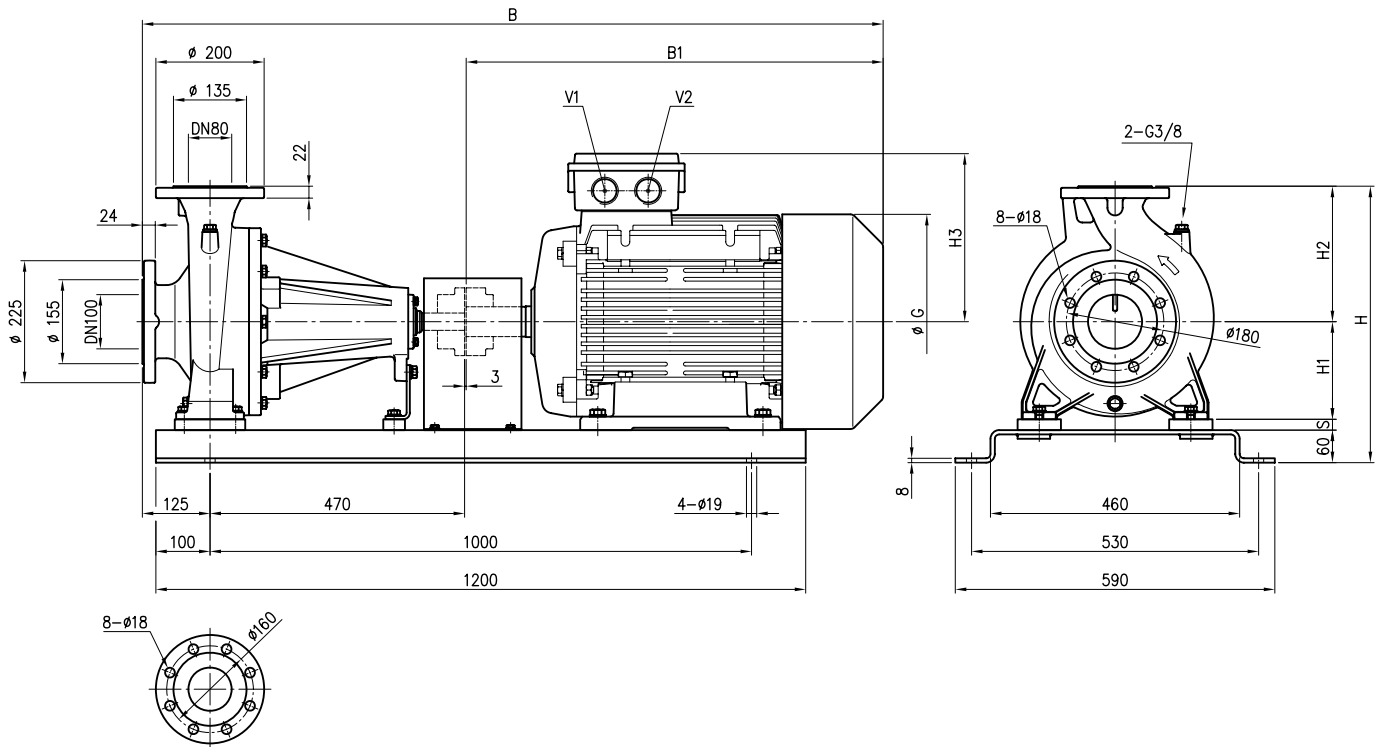

Pump type	Dimensions [mm]										Weight [kgf]
	H	H1	H2	H3	B	B1	G	S	V1	V2	
80-200/30	510	180	250	300	1366	768	399	20	M40x1.5	M40x1.5	356
80-200/37	510	180	250	300	1366	768	399	20	M40x1.5	M40x1.5	365
80-250/45	565	200	280	335	1407	809	465	25	M50x1.5	M50x1.5	440

PUMP 3LP 80-250/55

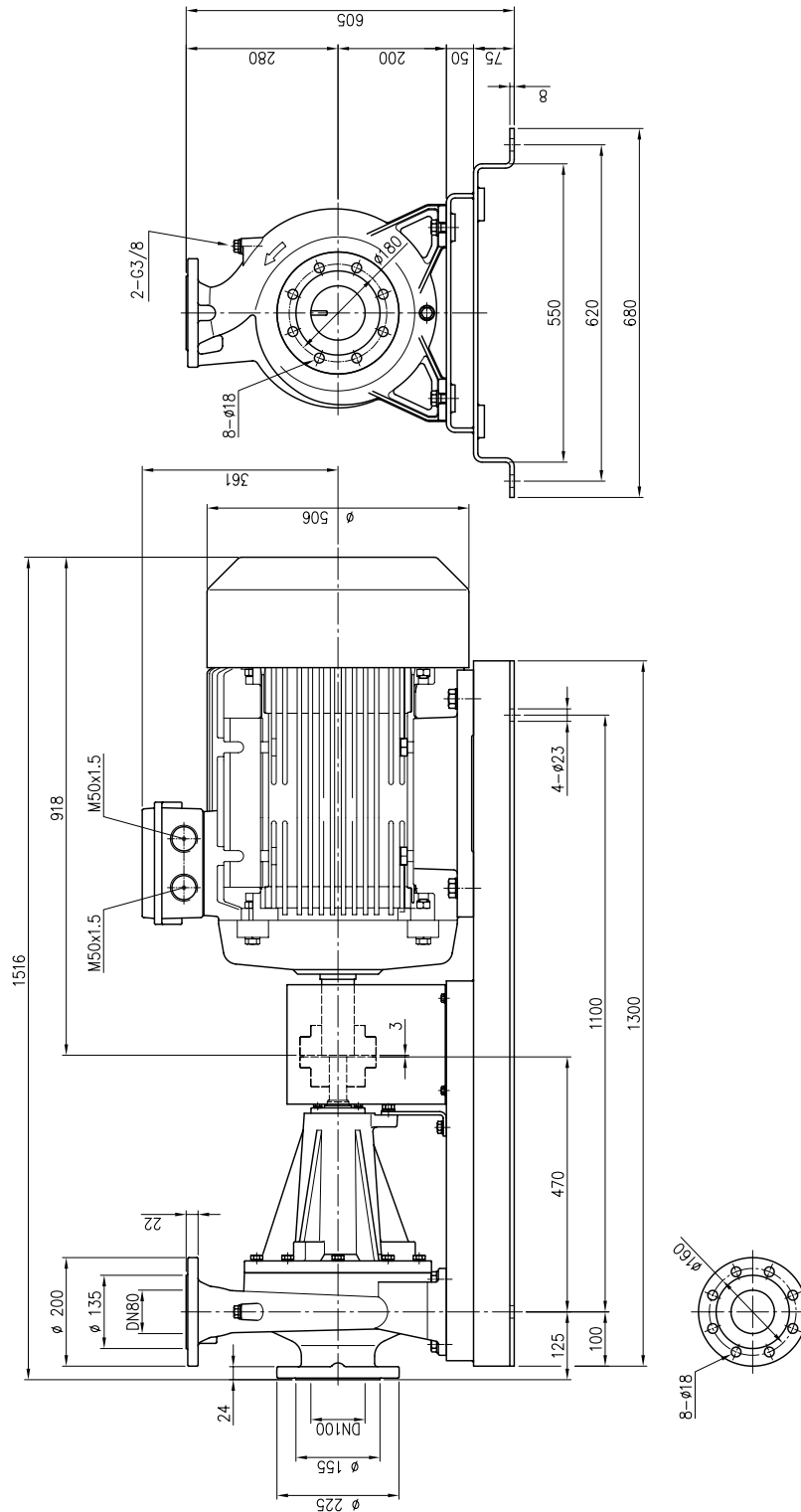

Weight: 528 kgf

PACKING 3(.)M

Pump type	Packing [mm]				Weight [kgf]		Pack type
	X	Y	Z	(*)	[1~]	[3~]	
32-125/1.1 (M)	250	300	450	450	21,5	29	1
32-160/1.5 (M)	280	330	430	470	24,2	31,7	
32-160/2.2 (M)		340	490	490	27,3	33,5	
32-200/3	350	488	550	550	-	41	2
32-200/4					-	44	
32-200/5.5					-	60,5	
32-200/7.5					-	65,6	
40-125/1.5 (M)	250	300	450	450	22,3	30	1
40-125/2.2 (M)	280	340	490	490	24,7	31,5	
40-160/3	350	488	550	550	-	28,8	2
40-160/4					-	46,5	
40-200/5.5			-	61,5			
40-200/7.5			-	68,1			
40-200/11	-	-	700	-	-	79,4	
50-125/2.2 (M)	280	340	490	490	30,8	38	1
50-125/3	350	488	550	550	-	37	
50-125/4					-	47	
50-160/5.5			-	51,5			
50-160/7.5			-	67,6			
50-200/9.2	-	-	700	-	-	73,5	
50-200/11	-	-	-	-	-	78,9	
50-200/15	390	532	-	880	-	113,1	2
65-125/4	350	488	550	550	-	41,7	
65-125/5.5					-	53,2	
65-125/7.5					-	56,6	
65-160/7.5	-	-	700	-	-	60,6	
65-160/9.2	-	-	-	-	-	66,5	
65-160/11	-	-	-	-	-	72,4	
65-160/15	-	-	-	-	-	112,1	
65-200/15	390	532	-	880	-	115,1	
65-200/18.5					-	127,3	
65-200/22					-	134,1	
80-160/11	370	538	-	680	-	105,4	
80-160/15R	370	527	-	860	-	136,1	
80-160/15					-	137,1	
80-160/18.5					-	151,3	

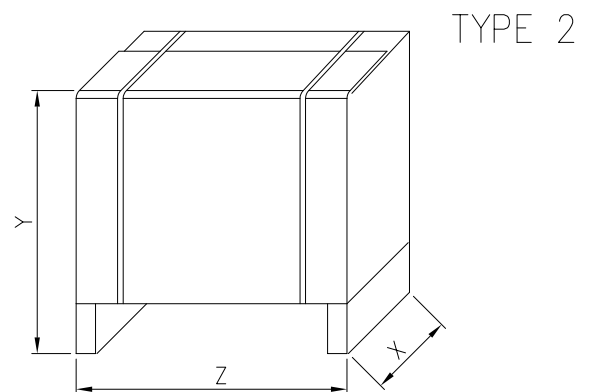
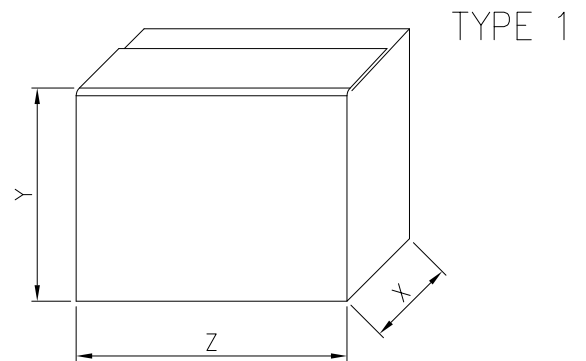

PACKING 3(.)S

Pump type	Packing [mm]			Weight Kgf	Pack Type		
	X	Y	Z				
32-125/1.1	450	250	300	36,3	1		
32-160/1.5	350	488	580	35,9			
32-160/2.2				51			
(**) 32-200/3.0	370	538	680	51,9	2		
32-200/3.0	350	498	700	51,9			
32-200/4.0				74,3			
32-200/5.5				82,1			
32-200/7.5				67			
40-125/1.5	350	488	580	33,3			
40-125/2.2				45,4			
40-160/3.0	350	498	700	49			
40-160/4.0				76,4			
40-200/5.5				84,2			
40-200/7.5				116			
40-200/11	390	598	970	146,3			
50-125/2.2	330	493	680	37,8			
50-125/3.0	350	498	700	49,6			
50-125/4.0				47,6			
50-160/5.5				84			
50-160/7.5				95,7			
50-200/9.2	390	598	880	116			
50-200/11				139,9			
50-200/15				172,9			
65-125/4.0				350	498	700	69
65-125/5.5	77,4						
65-125/7.5	85						
65-160/7.5	92						
65-160/9.2	390	598	880	103			
65-160/11				970	107,9		
65-160/15				138			
65-200/15				880	147,6		
65-200/18.5	500	727	1100	970	166,5		
65-200/22				235			
65-250/30				480	722	1080	339
65-250/37				141			
80-160/11	370	597	860	156,9			
80-160/15R				163			
80-160/15				168,6			
80-160/18.5				593	940	225,5	
80-200/22	480	722	1080	284			
80-200/30				344			
80-200/37				488	354		
80-250/37				429			
80-250/45	580	822	1380	517			
80-250/55				517			

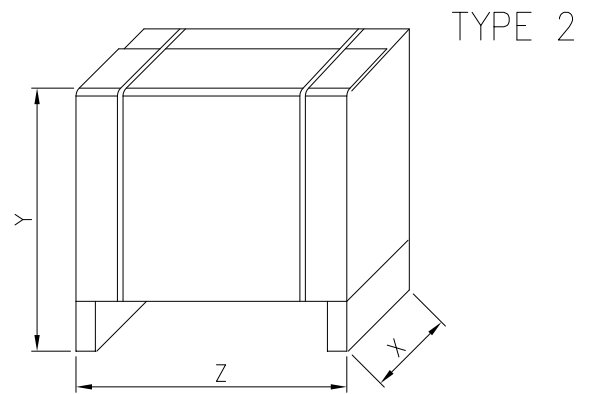
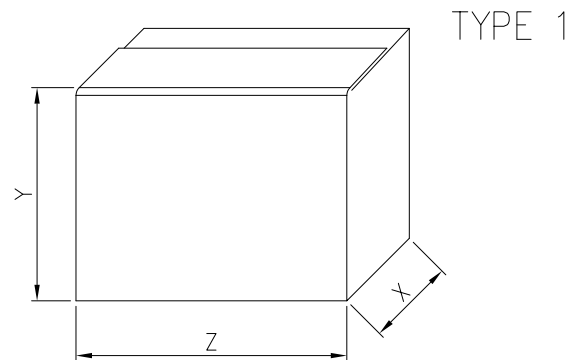

(**) Only for "Z" version

PACKING 3(.)P

Pump type	Packing [mm]			Weight Kgf	
	Z	X	Y		
32-125/1.1	1200	800	394	46.7	
32-160/1.5			434	52.3	
32-160/2.2				53.5	
32-200/3.0				71.5	
32-200/4.0				75.1	
32-200/5.5				97	
32-200/7.5				112.2	
40-125/1.5				394	49.8
40-125/2.2					51
40-160/3.0				434	81
40-160/4.0					67.6
40-200/5.5					98
40-200/7.5				482	106.9
40-200/11					127.8
50-125/2.2					75
50-125/3.0				434	82.5
50-125/4.0					84.6
50-160/5.5					98
50-160/7.5				482	106.9
50-200/9.2					111
50-200/11				502	128.3
50-200/15					135.4
65-125/4.0					85.1
65-125/5.5				482	99
65-125/7.5					109.4
65-160/7.5					115.4
65-160/9.2				502	118
65-160/11					124.8
65-160/15					129
65-200/15					137
65-200/18.5				547	135.2
65-200/22					189
65-250/30					354
65-250/37				685	373
80-160/11					174.8
80-160/15R					186
80-160/15				593	186
80-160/18.5					181.2
80-200/22				633	259
80-200/30					356
80-200/37		685	365		
80-250/37			377		
80-250/45		745	440		
80-250/55		811	528		

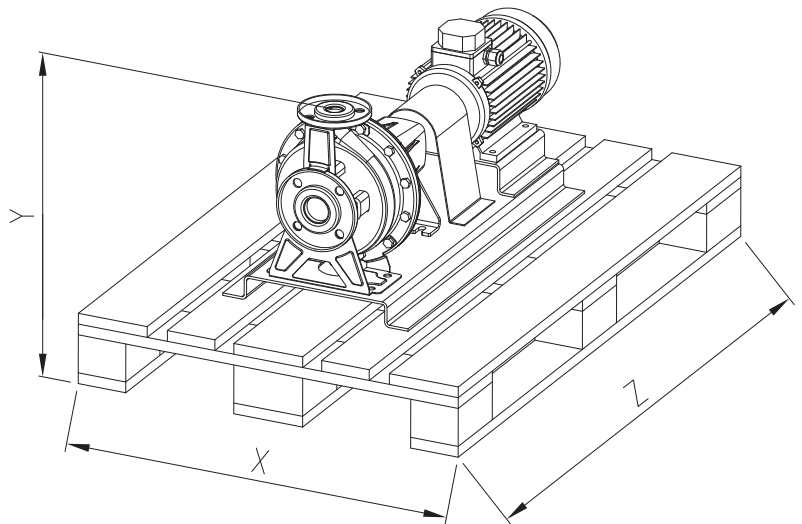

MOTOR DATA 3(.)M

Pump type		Power		Efficiency		Capacitor		Efficiency (% load)			Input		Full load current				Locked rotor current			
Single Phase	Three Phase	[kW]	[HP]	Single Phase	Three Phase	Single Phase	Three Phase	Three phase			Single Phase	Three Phase	[A]				[A]			
								μF	V	η %			230 V	230 V	400 V	690 V	230 V	230 V	400 V	690 V
3(.)M 32-125/1.1 M	3(.)M(Z) 32-125/1.1	1,1	1,5	-	IE3	31,5	450	83,5	84,3	84,6	1,51	1,77	6,7	5,8	3,3	-	23,5	47,4	27,4	-
3(.)M 32-160/1.5 M	3(.)M(Z) 32-160/1.5	1,5	2,0	-	IE3	40	450	83,5	84,3	84,6	2,10	1,77	9,6	5,8	3,3	-	47	47,4	27,4	-
3(.)M 32-160/2.2 M	3(.)M(Z) 32-160/2.2	2,2	3,0	-	IE3	50	450	86,2	87,0	86,0	2,95	2,55	13,3	8,2	4,7	-	63,8	66,6	38,4	-
-	3(.)M(Z) 32-200/3.0	3,0	4,0	-	IE3	-	-	85,9	87,5	87,1	-	3,44	-	11,1	6,4	-	-	90,0	52,0	-
-	3(.)M(Z) 32-200/4.0	4,0	5,5	-	IE3	-	-	85,8	88,3	88,4	-	4,52	-	15,1	8,7	-	-	131,8	76,1	-
-	3(.)M(Z) 32-200/5.5	5,5	7,5	-	IE3	-	-	89,2	90,6	90,4	-	6,09	-	-	10,6	6,1	-	-	115,3	67,0
-	3(.)M(Z) 32-200/7.5	7,5	10,0	-	IE3	-	-	89,0	90,7	90,8	-	8,26	-	-	13,6	7,9	-	-	144,0	83,0
3(.)M 40-125/1.5 M	3(.)M(Z) 40-125/1.5	1,5	2,0	-	IE3	40	450	83,5	84,3	84,6	2,10	1,77	9,6	5,8	3,3	-	47	47,4	27,4	-
3(.)M 40-125/2.2 M	3(.)M(Z) 40-125/2.2	2,2	3,0	-	IE3	50	450	86,2	87,0	86,0	2,95	2,55	13,3	8,2	4,7	-	63,8	66,6	38,4	-
-	3(.)M(Z) 40-160/3.0	3,0	4,0	-	IE3	-	-	85,9	87,5	87,1	-	3,44	-	11,1	6,4	-	-	90,0	52,0	-
-	3(.)M(Z) 40-160/4.0	4,0	5,5	-	IE3	-	-	85,8	88,3	88,4	-	4,52	-	15,1	8,7	-	-	131,8	76,1	-
-	3(.)M(Z) 40-200/5.5	5,5	7,5	-	IE3	-	-	89,2	90,6	90,4	-	6,09	-	-	10,6	6,1	-	-	115,3	67,0
-	3(.)M(Z) 40-200/7.5	7,5	10,0	-	IE3	-	-	89,0	90,7	90,8	-	8,26	-	-	13,6	7,9	-	-	144,0	83,0
-	3(.)M(Z) 40-200/11	11,0	15,0	-	IE3	-	-	90,4	91,2	91,8	-	11,98	-	-	21,3	12,3	-	-	184,0	107,0
3(.)M 50-125/2.2 M	3(.)M(Z) 50-125/2.2	2,2	3,0	-	IE3	50	450	86,2	87,0	86,0	2,95	2,55	13,3	8,2	4,7	-	63,8	66,6	38,4	-
-	3(.)M(Z) 50-125/3.0	3,0	4,0	-	IE3	-	-	85,9	87,5	87,1	-	3,62	-	11,1	6,4	-	-	90,0	52,0	-
-	3(.)M(Z) 50-125/4.0	4,0	5,5	-	IE3	-	-	85,8	88,3	88,4	-	4,52	-	15,1	8,7	-	-	131,8	76,1	-
-	3(.)M(Z) 50-160/5.5	5,5	7,5	-	IE3	-	-	89,2	90,6	90,4	-	6,09	-	-	10,6	6,1	-	-	115,3	67,0
-	3(.)M(Z) 50-160/7.5	7,5	10,0	-	IE3	-	-	89,0	90,7	90,8	-	8,26	-	-	13,6	7,9	-	-	144,0	83,0
-	3(.)M(Z) 50-200/9.2	9,2	12,5	-	IE3	-	-	90,1	90,8	90,9	-	10,12	-	-	17,2	10,0	-	-	166,0	96,0
-	3(.)M(Z) 50-200/11	11,0	15,0	-	IE3	-	-	90,4	91,2	91,8	-	11,98	-	-	21,3	12,3	-	-	184,0	107,0
-	3(.)M(Z) 50-200/15	15,0	20,0	-	IE3	-	-	91,2	92,0	91,9	-	16,32	-	-	27,7	17,3	-	-	225,0	130,0
-	3(.)M(Z) 65-125/4	4,0	5,5	-	IE3	-	-	85,8	88,3	88,4	-	4,52	-	15,1	8,7	-	-	131,8	76,1	-
-	3(.)M(Z) 65-125/5.5	5,5	7,5	-	IE3	-	-	89,2	90,6	90,4	-	6,09	-	-	10,6	6,1	-	-	115,3	67,0
-	3(.)M(Z) 65-125/7.5	7,5	10,0	-	IE3	-	-	89,0	90,7	90,8	-	8,26	-	-	13,6	7,9	-	-	144,0	83,0
-	3(.)M(Z) 65-160/7.5	7,5	10,0	-	IE3	-	-	89,0	90,7	90,8	-	8,26	-	-	13,6	7,9	-	-	144,0	83,0
-	3(.)M(Z) 65-160/9.2	9,2	12,5	-	IE3	-	-	90,1	90,8	90,9	-	10,12	-	-	17,2	10,0	-	-	166,0	96,0
-	3(.)M(Z) 65-160/11	11,0	15,0	-	IE3	-	-	90,4	91,2	91,8	-	11,98	-	-	21,3	12,3	-	-	184,0	107,0
-	3(.)M(Z) 65-160/15	15,0	20,0	-	IE3	-	-	91,2	92,0	91,9	-	16,32	-	-	27,7	17,3	-	-	225,0	130,0
-	3(.)M(Z) 65-200/15	15,0	20,0	-	IE3	-	-	91,2	92,0	91,9	-	16,32	-	-	27,7	17,3	-	-	225,0	130,0
-	3(.)M(Z) 65-200/18.5	18,5	25,0	-	IE3	-	-	91,6	93,0	92,6	-	19,98	-	-	35,0	20,3	-	-	328,0	190,0
-	3(.)M(Z) 65-200/22	22,0	30,0	-	IE3	-	-	92,0	93,1	93,2	-	23,58	-	-	39,7	23,6	-	-	391,0	227,0
-	3LM 80-160/11	11,0	15,0	-	IE3	-	-	90,4	91,2	91,8	-	11,98	-	-	21,3	12,3	-	-	184,0	107,0
-	3LM 80-160/15R	15,0	20,0	-	IE3	-	-	91,2	92,0	91,9	-	16,32	-	-	27,7	17,3	-	-	225,0	130,0
-	3LM 80-160/15	15,0	20,0	-	IE3	-	-	91,2	92,0	91,9	-	16,32	-	-	27,7	17,3	-	-	225,0	130,0
-	3LM 80-160/18.5	18,5	25,0	-	IE3	-	-	91,6	93,0	92,6	-	19,98	-	-	35,0	20,3	-	-	328,0	190,0

MOTOR DATA 3(.)S-3(.)P

Pump type		Motor			Efficiency	Input [kW]	Efficiency (% load) and power-factor				Full load current [A]			Locked rotor current [A]		
		Motor Size	Power [kW] [HP]				50%	75%	100%	cos-φ	230 V	400 V	690 V	230 V	400 V	690 V
3(.)S(Z) 32-125/1.1	3(.)P 32-125/1.1	80	1.1	1.5	IE3	1,26					78,7	81,7	82,7	0,76	4,2	2,4
3(.)S(Z) 32-160/1.5	3(.)P 32-160/1.5	90S	1.5	2	IE3	1,77	83,2	84,8	84,2	0,85	5,2	3,0	-	43,6	25,2	-
3(.)S(Z) 32-160/2.2	3(.)P 32-160/2.2	90L	2.2	3	IE3	2,61	85,0	86,2	86,5	0,82	8,0	4,6	-	73,3	42,3	-
3(.)S(Z) 32-200/3.0	3(.)P 32-200/3.0	100L	3	4	IE3	3,45	82,3	85,8	87,1	0,89	9,7	5,6	-	85,4	49,3	-
3(.)S(Z) 32-200/4.0	3(.)P 32-200/4.0	112M	4	5.5	IE3	4,51	86,8	87,8	88,1	0,93	12,1	7,0	-	116,4	67,2	-
3(.)S(Z) 32-200/5.5	3(.)P 32-200/5.5	132S	5.5	7.5	IE3	6,24	88,0	88,5	89,2	0,90	-	10,0	5,8	-	89,0	51,4
3(.)S(Z) 32-200/7.5	3(.)P 32-200/7.5		7.5	10	IE3	8,35	88,6	89,2	90,1	0,92	-	13,1	7,6	-	116,6	67,3
3(.)S(Z) 40-125/1.5	3(.)P 40-125/1.5	90S	1.5	2	IE3	1,77	83,2	84,8	84,2	0,85	5,2	3,0	-	43,6	25,2	-
3(.)S(Z) 40-125/2.2	3(.)P 40-125/2.2	90L	2.2	3	IE3	2,61	85,0	86,2	86,5	0,82	8,0	4,6	-	73,3	42,3	-
3(.)S(Z) 40-160/3.0	3(.)P 40-160/3.0	100L	3	4	IE3	3,45	82,3	85,8	87,1	0,89	9,7	5,6	-	85,4	49,3	-
3(.)S(Z) 40-160/4.0	3(.)P 40-160/4.0	112M	4	5.5	IE3	4,51	86,8	87,8	88,1	0,93	12,1	7,0	-	116,4	67,2	-
3(.)S(Z) 40-200/5.5	3(.)P 40-200/5.5	132M	5.5	7.5	IE3	6,24	88,0	88,5	89,2	0,90	-	10,0	5,8	-	89,0	51,4
3(.)S(Z) 40-200/7.5	3(.)P 40-200/7.5		7.5	10	IE3	8,35	88,6	89,2	90,1	0,92	-	13,1	7,6	-	116,6	67,3
3(.)S(Z) 40-200/11	3(.)P 40-200/11	160M	11	15	IE3	12,15	87,4	89,8	91,2	0,89	-	19,7	11,4	-	179,3	103,5
3(.)S(Z) 50-125/2.2	3(.)P 50-125/2.2	90L	2.2	3	IE3	2,61	85,0	86,2	86,5	0,82	8,0	4,6	-	73,3	42,3	-
3(.)S(Z) 50-125/3.0	3(.)P 50-125/3.0	100L	3	4	IE3	3,45	82,3	85,8	87,1	0,89	9,7	5,6	-	85,4	49,3	-
3(.)S(Z) 50-125/4.0	3(.)P 50-125/4.0	112M	4	5.5	IE3	4,51	86,8	87,8	88,1	0,93	12,1	7,0	-	116,4	67,2	-
3(.)S(Z) 50-160/5.5	3(.)P 50-160/5.5	132S	5.5	7.5	IE3	6,24	88,0	88,5	89,2	0,90	-	10,0	5,8	-	89,0	51,4
3(.)S(Z) 50-160/7.5	3(.)P 50-160/7.5		7.5	10	IE3	8,35	88,6	89,2	90,1	0,92	-	13,1	7,6	-	116,6	67,3
3(.)S(Z) 50-200/9.2	3(.)P 50-200/9.2	132M	9.2	12.5	IE3	10,17	88,6	89,8	90,7	0,89	-	16,5	9,5	-	166,7	96,2
3(.)S(Z) 50-200/11	3(.)P 50-200/11	160M	11	15	IE3	12,15	87,4	89,8	91,2	0,89	-	19,7	11,4	-	179,3	103,5
3(.)S(Z) 50-200/15	3(.)P 50-200/15		15	20	IE3	16,46	91,0	91,3	91,9	0,89	-	26,7	15,4	-	259,0	149,5
3(.)S(Z) 65-125/4	3(.)P 65-125/4	112M	4	5.5	IE3	4,51	86,8	87,8	88,1	0,93	12,1	7,0	-	116,4	67,2	-
3(.)S(Z) 65-125/5.5	3(.)P 65-125/5.5		5.5	7.5	IE3	6,24	88,0	88,5	89,2	0,90	-	10,0	5,8	-	89,0	51,4
3(.)S(Z) 65-125/7.5	3(.)P 65-125/7.5	132S	7.5	10	IE3	8,35	88,6	89,2	90,1	0,92	-	13,1	7,6	-	116,6	67,3
3(.)S(Z) 65-160/7.5	3(.)P 65-160/7.5		7.5	10	IE3	8,35	88,6	89,2	90,1	0,92	-	13,1	7,6	-	116,6	67,3
3(.)S(Z) 65-160/9.2	3(.)P 65-160/9.2	132M	9.2	12.5	IE3	10,17	88,6	89,8	90,7	0,89	-	16,5	9,5	-	166,7	96,2
3(.)S(Z) 65-160/11	3(.)P 65-160/11	160M	11	15	IE3	12,15	87,4	89,8	91,2	0,89	-	19,7	11,4	-	179,3	103,5
3(.)S(Z) 65-160/15	3(.)P 65-160/15		15	20	IE3	16,46	91,0	91,3	91,9	0,89	-	26,7	15,4	-	259,0	149,5
3(.)S(Z) 65-200/15	3(.)P 65-200/15	160L	15	20	IE3	16,46	91,0	91,3	91,9	0,89	-	26,7	15,4	-	259,0	149,5
3(.)S(Z) 65-200/18.5	3(.)P 65-200/18.5		18.5	25	IE3	20,12	91,6	92,8	92,4	0,88	-	33,0	19,1	-	353,1	203,9
3(.)S(Z) 65-200/22	3(.)P 65-200/22	180	22	30	IE3	23,69	92,3	92,9	92,9	0,90	-	38,0	22,0	-	361,0	209,0
3LS 65-250/30	3LP 65-250/30	200	30	40	IE3	31,94	92,8	93,9	94,0	0,89	-	51,8	30,0	-	459,0	270,0
3LS 65-250/37	3LP 65-250/37		37	50	IE3	38,97	93,0	93,9	93,8	0,90	-	62,5	36,0	-	496,0	288,0
3LS 80-160/11	3LP 80-160/11	160M	11	15	IE3	12,15	87,4	89,8	91,2	0,89	-	19,7	11,4	-	179,3	103,5
3LS 80-160/15R	3LP 80-160/15R		15	20	IE3	16,46	91,0	91,3	91,9	0,89	-	26,7	15,4	-	259,0	149,5
3LS 80-160/15	3LP 80-160/15	160L	15	20	IE3	16,46	91,0	91,3	91,9	0,89	-	26,7	15,4	-	259,0	149,5
3LS 80-160/18.5	3LP 80-160/18.5		18.5	25	IE3	20,12	91,6	92,8	92,4	0,88	-	33,0	19,1	-	353,1	203,9
3LS 80-200/22	3LP 80-200/22	180	22	30	IE3	23,69	92,3	92,9	92,9	0,90	-	38,0	22,0	-	361,0	209,0
3LS 80-200/30	3LP 80-200/30	200	30	40	IE3	31,94	92,8	93,9	94,0	0,89	-	51,8	30,0	-	459,0	270,0
3LS 80-200/37	3LP 80-200/37		37	50	IE3	38,97	93,0	93,9	93,8	0,90	-	62,5	36,0	-	496,0	288,0
3LS 80-250/37	3LP 80-250/37	225	37	50	IE3	38,97	93,0	93,9	93,8	0,90	-	62,5	36,0	-	496,0	288,0
3LS 80-250/45	3LP 80-250/45		45	60	IE3	47,49	93,2	94,6	94,8	0,92	-	74,5	43,0	-	633,0	366,0
3LS 80-250/55	3LP 80-250/55	250	55	75	IE3	58,30	93,6	94,5	94,4	0,90	-	93,5	54,0	-	935,0	540,0

NOISE DATA 3(.)M

Pump type		Power		L _{pA} - dB(A) *
Single Phase	Three Phase	[kW]	[HP]	
3(.)M 32-125/1.1 M	3(.)M(Z) 32-125/1.1	1.1	1.5	<70
3(.)M 32-160/1.5 M	3(.)M(Z) 32-160/1.5	1.5	2.0	
3(.)M 32-160/2.2 M	3(.)M(Z) 32-160/2.2	2.2	3.0	
-	3(.)M(Z) 32-200/3.0	3.0	4.0	71
-	3(.)M(Z) 32-200/4.0	4.0	5.5	75
-	3(.)M(Z) 32-200/5.5	5.5	7.5	
-	3(.)M(Z) 32-200/7.5	7.5	10.0	
3(.)M 40-125/1,5 M	3(.)M(Z) 40-125/1.5	1.5	2.0	<70
3(.)M 40-125/2.2 M	3(.)M(Z) 40-125/2.2	2.2	3.0	
-	3(.)M(Z) 40-160/3.0	3.0	4.0	71
-	3(.)M(Z) 40-160/4.0	4.0	5.5	75
-	3(.)M(Z) 40-200/5.5	5.5	7.5	
-	3(.)M(Z) 40-200/7.5	7.5	10.0	
-	3(.)M(Z) 40-200/11	11.0	15.0	80
3(.)M 50-125/2.2 M	3(.)M(Z) 50-125/2.2	2.2	3.0	<70
-	3(.)M(Z) 50-125/3.0	3.0	4.0	71
-	3(.)M(Z) 50-125/4.0	4.0	5.5	75
-	3(.)M(Z) 50-160/5.5	5.5	7.5	
-	3(.)M(Z) 50-160/7.5	7.5	10.0	
-	3(.)M(Z) 50-200/9.2	9.2	12.5	80
-	3(.)M(Z) 50-200/11	11.0	15.0	
-	3(.)M(Z) 50-200/15	15.0	20.0	
-	3(.)M(Z) 65-125/4	4.0	5.5	71
-	3(.)M(Z) 65-125/5.5	5.5	7.5	75
-	3(.)M(Z) 65-125/7.5	7.5	10.0	
-	3(.)M(Z) 65-160/7.5	7.5	10.0	
-	3(.)M(Z) 65-160/9.2	9.2	12.5	80
-	3(.)M(Z) 65-160/11	11.0	15.0	
-	3(.)M(Z) 65-160/15	15.0	20.0	
-	3(.)M(Z) 65-200/15	15.0	20.0	83-82
-	3(.)M(Z) 65-200/18.5	18.5	25.0	
-	3(.)M(Z) 65-200/22	22.0	30.0	
-	3LM 80-160/11	11.0	15.0	80
-	3LM 80-160/15R	15.0	20.0	
-	3LM 80-160/15	15.0	20.0	
-	3LM 80-160/18.5	18.5	25.0	83-82

* Mean value of several measures at 1m distance around the pump.
Tolerance ± 2.5 dB.

NOISE DATA 3(.)S-3(.)P

Pump type		Motor Size	Power		L _{pA} - dB(A) *
			[kW]	[HP]	
3(.)S(Z) 32-125/1.1	3(.)P 32-125/1.1	80	1.1	1.5	<70
3(.)S(Z) 32-160/1.5	3(.)P 32-160/1.5	90S	1.5	2	
3(.)S(Z) 32-160/2.2	3(.)P 32-160/2.2	90L	2.2	3	
3(.)S(Z) 32-200/3.0	3(.)P 32-200/3.0	100L	3	4	
3(.)S(Z) 32-200/4.0	3(.)P 32-200/4.0	112M	4	5.5	<70
3(.)S(Z) 32-200/5.5	3(.)P 32-200/5.5	132S	5.5	7.5	72
3(.)S(Z) 32-200/7.5	3(.)P 32-200/7.5	132S	7.5	10	
3(.)S(Z) 40-125/1.5	3(.)P 40-125/1.5	90S	1.5	2	<70
3(.)S(Z) 40-125/2.2	3(.)P 40-125/2.2	90L	2.2	3	
3(.)S(Z) 40-160/3.0	3(.)P 40-160/3.0	100L	3	4	
3(.)S(Z) 40-160/4.0	3(.)P 40-160/4.0	112M	4	5.5	
3(.)S(Z) 40-200/5.5	3(.)P 40-200/5.5	132S	5.5	7.5	72
3(.)S(Z) 40-200/7.5	3(.)P 40-200/7.5	132S	7.5	10	
3(.)S(Z) 40-200/11	3(.)P 40-200/11	160M	11	15	74
3(.)S(Z) 50-125/2.2	3(.)P 50-125/2.2	90L	2.2	3	<70
3(.)S(Z) 50-125/3.0	3(.)P 50-125/3.0	100L	3	4	
3(.)S(Z) 50-125/4.0	3(.)P 50-125/4.0	112M	4	5.5	<70
3(.)S(Z) 50-160/5.5	3(.)P 50-160/5.5	132S	5.5	7.5	72
3(.)S(Z) 50-160/7.5	3(.)P 50-160/7.5	132S	7.5	10	
3(.)S(Z) 50-200/9.2	3(.)P 50-200/9.2	132M	9.2	12.5	
3(.)S(Z) 50-200/11	3(.)P 50-200/11	160M	11	15	
3(.)S(Z) 50-200/15	3(.)P 50-200/15	160M	15	20	74
3(.)S(Z) 65-125/4	3(.)P 65-125/4	112M	4	5.5	<70
3(.)S(Z) 65-125/5.5	3(.)P 65-125/5.5	132S	5.5	7.5	72
3(.)S(Z) 65-125/7.5	3(.)P 65-125/7.5	132S	7.5	10	
3(.)S(Z) 65-160/7.5	3(.)P 65-160/7.5	132S			
3(.)S(Z) 65-160/9.2	3(.)P 65-160/9.2	132M	9.2	12.5	
3(.)S(Z) 65-160/11	3(.)P 65-160/11	160M	11	15	74
3(.)S(Z) 65-160/15	3(.)P 65-160/15	160M	15	20	
3(.)S(Z) 65-200/15	3(.)P 65-200/15	160M			
3(.)S(Z) 65-200/18.5	3(.)P 65-200/18.5	160L	18,5	25	
3(.)S(Z) 65-200/22	3(.)P 65-200/22	180	22	30	77
3LS 65-250/30	3LP 65-250/30	200	30	40	78
3LS 65-250/37	3LP 65-250/37	200	37	50	
3LS 80-160/11	3LP 80-160/11	160M	11	15	74
3LS 80-160/15R	3LP 80-160/15R	160M	15	20	
3LS 80-160/15	3LP 80-160/15	160M	15	20	
3LS 80-160/18.5	3LP 80-160/18.5	160L	18,5	25	
3LS 80-200/22	3LP 80-200/22	180	22	30	77
3LS 80-200/30	3LP 80-200/30	200	30	40	78
3LS 80-200/37	3LP 80-200/37	200	37	50	
3LS 80-250/37	3LP 80-250/37	200	37	50	
3LS 80-250/45	3LP 80-250/45	225	45	60	
3LS 80-250/55	3LP 80-250/55	250	55	75	81

* Mean value of several measures at 1m distance around the pump.

Tolerance ± 2.5 dB.

Sound pressure level of motor pumps with AEG